

Archaeological Investigations within San Pedro Springs Park (41BX19), San Antonio, Bexar County, Texas

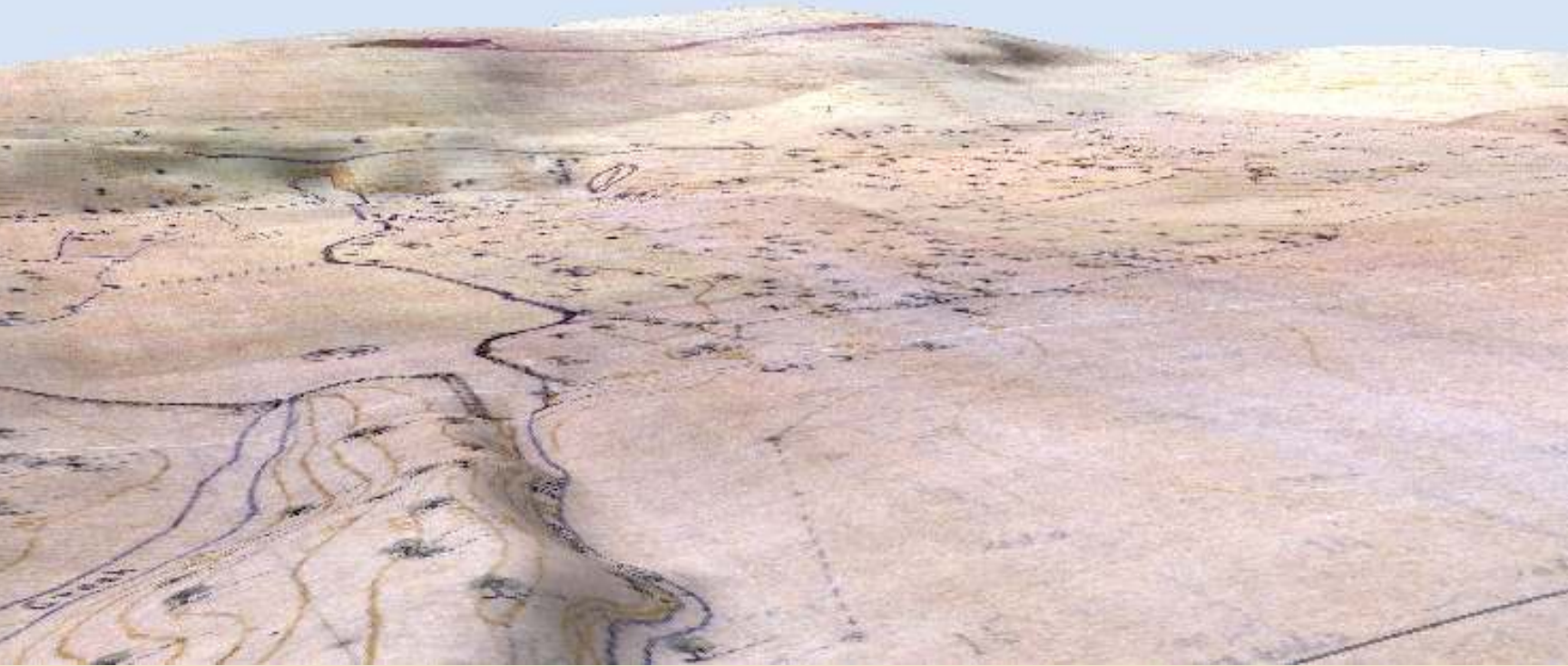

by

Raymond Mauldin, Stephen Smith, Sarah Wigley, Antonia Figueroa, and Clinton McKenzie

with contributions by

Laura Carbajal, Cynthia Munoz, Barbara Meissner, Kristi Nichols, Melissa Eiring, and Robert Garcia, Jr.

Principal Investigator

Raymond Mauldin

Original Principal Investigator

Steve A. Tomka

Texas Antiquities Permit No. 6727

REDACTED

Prepared for:
Adams Environmental, Inc.
12000 Crownpoint Drive, Suite 120
San Antonio, Texas 78233

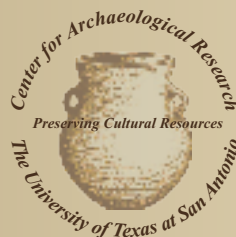

Prepared by:
Center for Archaeological Research
The University of Texas at San Antonio
One UTSA Circle
San Antonio, Texas 78249-1644
Archaeological Report, No. 443

**Archaeological Investigations Associated within
San Pedro Springs Park (41BX19),
San Antonio, Bexar County, Texas**

by

Raymond Mauldin, Stephen Smith, Sarah Wigley, Antonia Figueroa, and Clinton McKenzie

with contributions by

Laura Carbajal, Cynthia Munoz, Barbara Meissner, Kristi Nichols, Melissa Eiring, and Robert Garcia, Jr.

Principal Investigator
Raymond P. Mauldin
Original Principal Investigator
Steve A. Tomka

Texas Antiquities Committee Permit No. 6727

REDACTED



Adams Environmental, Inc.
12000 Crownpoint Drive, Suite 120
San Antonio, Texas 78233

Center for Archaeological Research
The University of Texas at San Antonio
One UTSA Circle
San Antonio, Texas 78249
Archaeological Report No. 443

Abstract:

The University of Texas at San Antonio Center for Archaeological Research (UTSA-CAR) contracted with Adams Environmental, Inc. to provide archaeological services to Capital Improvement Management (CIMS) of the City of San Antonio (COSA) related to the archaeological investigation of selected areas of San Pedro Springs Park in San Antonio, Bexar County, Texas. The CAR conducted archaeological testing at this National Register Site, 41BX19, from early December 2013 to mid-January of 2014. The goals of archaeological investigations were to identify and investigate any proto-historic and historic archaeological deposits associated with Colonial Period occupants of the area, including evidence of the first *acequia* and associated dam, and the location of the first presidio and villa. In addition, CAR was tasked with the investigation of any prehistoric cultural deposits encountered. This project was performed by staff archaeologists from the CAR. It was conducted under Texas Antiquities Permit No. 6727, with Dr. Steve Tomka serving as Principal Investigator (PI), and Kristi Nichols and Stephen Smith serving as Project Archaeologists. Dr. Tomka departed from UTSA shortly after the completion of fieldwork. At that time, Dr. Raymond Mauldin of CAR assumed PI responsibilities for the project.

One hundred and eleven shovel tests, eleven 1-x-1 m test units, two 50-x-50 cm units, two backhoe trenches, and several auger holes were excavated during this effort. Minimal artifactual evidence of colonial occupants was noted during the archaeological investigations. Several Native American bone tempered sherds that could reflect either Late Prehistoric Leon Plain or Goliad ware were recovered. However, no Spanish Majolicas or lead glazed wares were uncovered, and no gunflints were identified in the lithic assemblage. Due to various utility lines and other obstructions, backhoe trenches to search for the *acequia* and associated dam could not be excavated. It is likely that areas proposed for investigation of the *acequia* and associated dam have been disturbed by aforementioned utility lines as well as earlier construction within the park. No evidence of the specific location of the first presidio or villa was located. Shovel testing and test units revealed the presence of historic and prehistoric use of the park, though mixing of historic and prehistoric material, as well as other disturbances (e.g., rodents), was common in the deposits. However, there was an increase in prehistoric material with depth as revealed in shovel testing results. Shovel testing located Feature 1, a burned rock feature that possibly was associated with a sheet midden, as well as several areas with high densities of prehistoric materials. Test excavations, based on these shovel tests, suggest that Feature 1 is a discrete feature that lies below a widespread, low-density distribution of burned rock. Shovel testing also identified a high-density cluster of lithic, bone, and burned rock. The excavation of a 1-x-1 m test unit (TU 4) in this area produced over 4,000 pieces of debitage, with over 50% of this total coming from three levels. Burned rock, a variety of tools, faunal material, and charcoal were present throughout these levels.

Temporal placement of deposits relied on artifact typologies (e.g., ceramic types, lithic projectile points, lithic tool types) as well as two charcoal and four bone collagen radiocarbon dates. Artifact typologies suggest occupation as early as the Early Archaic as reflected by a possible Guadalupe tool. A series of Late Archaic Points (Castroville, Frio, Marcos, and Montell) and Late Prehistoric point forms (Edwards, Perdiz, and Scallorn) are present from several areas. In addition, a possible Middle Archaic La Jita point was recovered. The bone tempered Native American wares could date as early as AD 1250, though they could also reflect proto-historic or colonial age materials. Other ceramics primarily suggest a mid-nineteenth- to mid-twentieth-century occupation. Using the midpoints of the 1-sigma distribution, calibrated radiocarbon dates show use of San Pedro Park from as early as 100 AD (CAR 345; 1905 +/- 22 Radiocarbon Years Before Present [RCYBP]) to as recently as the early twentieth century. The more recent end of that range is a function of two late dates from two different areas of the park. The first of these is on a bison bone (CAR 344) that returned a date of 158 +/- 23 RCYBP. The second is on a bone consistent with a bison-sized animal (CAR 346) that produced a date of 155 +/- 23 RCYBP. The corrected, calibrated dates for these two samples range from AD 1670 to the early 1940s using the 1-sigma spread. The wide range of these dates is related to the flat calibration curve late in time. However, the most probable date range (ca. 36% probability) for these two dates is between AD 1729 and 1779, with a roughly 48% probability that they date prior to AD 1779.

Limited testing suggests that, with a few specific exceptions, the upper 30-40 cm of San Pedro Park is extensively disturbed. However, though some disturbances are present, at least three areas have materials in what appears to be good context. These include material dating to the Late Archaic, Late Prehistoric, and possibly the Proto-historic or Colonial Period. Based on historic maps, previous work, and the current investigation, CAR proposes a series of management areas for San Pedro Park. If work in these management areas follows these suggestions for various limits on subsurface impacts, CAR recommends that

renovation activities within the park be allowed to proceed. The Texas Historical Commission (THC), in a letter dated February 4, 2015, agreed with these recommendations. Finally, CAR provides several recommendations for public education facilities within the park.

In accordance with the THC Permit specifications and the Scope of Work for this project, all field notes, analytical notes, photographs, and other project related documents, along with a copy of the final report, will be curated at the CAR. After quantification and completion of analysis, and in consultation with THC and the COSA Office of Historic Preservation, artifacts possessing little scientific value were discarded pursuant to Chapter 26.27(g)(2) of the Antiquities Code of Texas. Artifact classes discarded specific to this project included samples of burned rock and snail shell, all unidentifiable metal, soil samples, and recent (post-1950) material.

Table of Contents:

Abstract	iii
Table of Contents	v
List of Figures	vii
List of Tables	ix
Acknowledgements	xi
Chapter 1: Introduction	1
Report Overview	4
Chapter 2: Project Setting	5
Climate	5
Geology and Hydrology	6
Biotic Zones and Floral and Faunal Resources	10
Paleoenvironment	11
Summary	12
Chapter 3: Cultural Environment	13
Prehistoric Background	13
Paleoindian Period (13,000-9000 BP)	13
Archaic Period (9000-1200 BP)	14
Late Prehistoric	16
Historic Background	18
Chapter 4: A History of San Pedro Park	23
Founding and Early Developments (1709-1851)	23
The Park and Early Renovations (1852-1899)	28
San Pedro Park in the Twentieth Century	31
Discussion	35
Chapter 5: Previous Archaeological Investigations at San Pedro Park	39
Avocational Exploration	39
Professional Investigations	39
Discussion	40
Chapter 6: Project Goals and Associated Field, Laboratory, and Curation Methods	43
Field Methods	43
Shovel Testing	44
Hand-Excavated 1-x-1 m Units	44
Backhoe Trenches	44
Laboratory Methods	44
Curation Methods	45
Chapter 7: Project Activities-Shovel Testing	47
Shovel Testing	47
Summary	59
Chapter 8: Project Activities-Test Units and Backhoe Trenches	61
Testing Areas	61
Map 1/Test Unit 7	63
Map 2/Test Unit 3	64
Map 3/Test Unit 2	65
Map 4/Test Unit 4	65
Map 5/Test Unit 13	70
Map 6/Test Units 1, 5, 6, and 10	74
Summary	81
Chapter 9: Project Activities-Searching for the San Pedro Colonial Dam and <i>Acequia</i>	83
Map 7/Test Units 8 and 9	87

Summary..... 90

Chapter 10: Artifacts Recovered..... 91

 Metal Objects..... 91

 Glass 92

 Ceramics 94

 Vertebrate Fauna 96

 Chipped Stone 97

 Chipped Stone Tools and Cores..... 104

 Burned Rock..... 108

 Summary..... 114

Chapter 11: Magnetic Susceptibility Values and the Integrity of the Deposits..... 117

 Summary..... 122

Chapter 12: Conclusions and Recommendations 123

 Recommendations 124

References Cited 131

Appendix A: Radiocarbon Information 149

Appendix B: Officials, Soldiers, and Civilians Who Were at Villa de Bejar in 1718..... 159

List of Figures:

Figure 1-1. The project area on a combined USGS 7.5-minute quadrangle map (San Antonio East and San Antonio West).....	1
Figure 1-2. San Pedro Park in 2013. The current park boundary is outlined in orange. Original, underlying map image is from Google Earth.....	3
Figure 2-1. Annual precipitation in San Antonio (1871-2011).....	5
Figure 2-2. Tree-ring based PDSI values for San Antonio Region, 1700-1799 (after Mauldin 2003a).....	7
Figure 2-3. Tree-ring based PDSI values for San Antonio Region, 1800-1899 (after Mauldin 2003a).....	7
Figure 2-4. Natural Regions of Texas and Geology of Bexar County. Compiled from USGS (2014a, 2014b) and TNRI (2014).....	8
Figure 2-5. Edwards Aquifer with major divisions, springs, and associated rivers (after Eckhardt 2014).....	9
Figure 2-6. Geology of San Pedro Park Region (after Barnes 1983).....	9
Figure 2-7. Soils in San Pedro Park (NRCS 2014) with major springs identified (Brune 1981). Base map is an aerial photograph from ESRI.....	10
Figure 2-8. Ecoregions of Texas with a focus on Bexar County (TPWD 2014).....	11
Figure 2-9. Long term, regional climate sequences for Central Texas.....	12
Figure 4-1. Map of San Pedro Springs, San Pedro Creek, and the San Pedro Ditch in 1860. Drawn by Friesleben, City Engineer (Plat Book 2:40, COSA 2014).....	27
Figure 4-2. San Pedro Springs Park, with major features identified, from around 1700 to about 1850 (Beaty Palmer Architects 2013; see also RVBK 1994).....	28
Figure 4-3. An 1870 City Map of San Pedro Park by C. Hartmill (from Cox 1999:9). Note hills depicted in the northeast corner of the park. Yellow circle highlights quarry area. Red circle highlights fishponds. Note <i>acequia</i> and San Pedro Creek as well as the apparent dam along the southern edge of the lake/springs.....	29
Figure 4-4. San Pedro Springs Park, with major features identified, around 1890 (Beaty Palmer Architects 2013; see also RVBK 1994).....	30
Figure 4-5. Trueheart Map of San Pedro Springs Park (1899), with major modern features identified for comparison. A copy of the map is on file at CAR-UTSA.....	32
Figure 4-6. Map of San Pedro Springs Park showing major alterations at the beginning of the twentieth century (Beaty Palmer Architects 2013; see also RVBK 1994).....	33
Figure 4-7. Early twentieth-century postcards. Top is hand-painted card from 1906, looking south. Bottom is a 1905 photo-based card, with the view likely to the north (Eckardt 2014).....	34
Figure 4-8. Map of San Pedro Springs Park, showing major alterations from around 1915 through roughly 1950 (Beaty Palmer Architects 2013; see also RVBK 1994).....	35
Figure 4-9. Aerial photo of San Pedro Park in 2014 (Google Earth).....	36
Figure 5-1. Composite map of the previous archaeological investigations conducted at 41BX19.....	41
Figure 5-2. Archaeologically sensitive portions of San Pedro Springs Park (after Meissner 2000c).....	42
Figure 6-1. Proposed trail system running along the western half of the park (base map courtesy of Beaty Palmer Architects 2013).....	43
Figure 6-2. Calcium carbonate coating on a biface from 110-120 cmbs.....	45
Figure 7-1. The distribution of shovel tests excavated in the project area.....	48
Figure 7-2. The distribution of shovel tests with no recovery (red), shovel tests with disturbed contexts from 40-60 cmbs (yellow), and tests with recovery and no deep disturbance (clear).....	49
Figure 7-3. Density of modern manufactured material in San Pedro Park shovel tests.....	52
Figure 7-4. Density of modern manufactured material in San Pedro Park shovel tests without highly disturbed ST 105.....	52
Figure 7-5. Density of glass in San Pedro Park shovel tests without highly disturbed ST 105.....	53
Figure 7-6. Density of chipped stone artifacts in San Pedro Park shovel tests.....	54
Figure 7-7. Kernel density map of modern material distribution in shovel tests, Levels 1-3, San Pedro Park.....	55
Figure 7-8. Kernel density map of modern material distribution in shovel tests, Levels 4-6, San Pedro Park.....	56
Figure 7-9. Kernel density map of chipped stone material distribution in shovel tests, Levels 1-6, San Pedro Park.....	57
Figure 7-10. Kernel density map of prehistoric material distribution in shovel tests, Levels 5 and 6, San Pedro Park.....	58
Figure 8-1. Contour map of San Pedro Park with individual testing areas identified by map reference.....	61

Figure 8-2. Contour map of San Pedro Park with individual testing areas identified by map reference. Base map is the 1899 Trueheart Map.....	62
Figure 8-3. Test Unit 7 in Map 1 area. Inset shows area location on Figure 8-1.....	63
Figure 8-4. Photograph of TU 7, Level 5. Note limestone bedrock floor.....	64
Figure 8-5. Test Unit 2 in Map 3 area. Inset shows area location on Figure 8-1.....	66
Figure 8-6. Test Unit 2 in Map 3 area. Looking south.....	66
Figure 8-7. Profile of Test Unit 2.....	67
Figure 8-8. Test Unit 4 in Map 4 area. Inset shows location on Figure 8-1.....	68
Figure 8-9. Photograph of Test Unit 4 in Map 4 area. Note the clear stratigraphic breaks in the upper deposits.....	68
Figure 8-10. Profile of Test Unit 4, Map 4 area.....	69
Figure 8-11. Backhoe trench in Map 4 area. Facing west. BHT 1 is at the center, with BHT 2 intersecting and running from left (south) to right (north). BHT 1 is partially backfilled in photo.....	71
Figure 8-12. Plan view of excavations in Map 4 area showing TU 4 and backhoe trenches. Measurements (cmbs) record the depth of the trench.....	71
Figure 8-13. South profile of a section of BHT 1, near east end of trench. Note that the deposits continue below bottom of trench.....	72
Figure 8-14. Test Unit 13 in Map 5 area. Inset shows location of area on Figure 8-1.....	73
Figure 8-15. Photograph of Test Unit 13 in Map 5 area. Note vertical cracks.....	73
Figure 8-16. Map 6 showing location of Test Units 1, 5, 6, and 10. Inset shows location of area on Figure 8-1.....	75
Figure 8-17. Profile drawing of east wall of Test Unit 1.....	76
Figure 8-18. Distribution of modern/historic material in Test Unit 1.....	77
Figure 8-19. Feature 1 in Test Unit 1, Level 8.....	77
Figure 8-20. Photograph of the east wall of Test Unit 5.....	78
Figure 8-21. Photograph of the north wall of Test Unit 6.....	79
Figure 8-22. Photograph of Test Unit 10, looking north.....	80
Figure 9-1. San Pedro Park, with Map 7 area identified.....	83
Figure 9-2. San Pedro Park, 1860 Friesleben Map, overlaid on modern park aerial photograph.....	84
Figure 9-3. San Pedro Park, City Engineer Map, C. Hartmill (from Cox 1999:9), August of 1870 overlaid on modern park aerial. Inset shows the southern section of the original map with the possible unnamed third trail or channel identified.....	85
Figure 9-4. San Pedro Park, 1899 Trueheart Map overlaid on modern park aerial.....	86
Figure 9-5. Utility lines identified by red paint to the east of the southern sidewalk exit.....	87
Figure 9-6. Additional utility lines associated with area of <i>acequia</i> . Building in top and bottom photos is visible in Figure 9-5 to right.....	88
Figure 9-7. Locations for Test Units 8 and 9, Map 7 area.....	88
Figure 9-8. Test Units 8 and 9. Note gravel fill in floor on east, in east wall, and in north wall of Test Unit 8. Sidewalk is roughly 1.5 m to the east.....	89
Figure 10-1. Metal weight (grams) from Test Units 1, 2, 3, 4, 5, 6, 7, and 10 by level.....	91
Figure 10-2. Selected metal objects, including 1917 U.S. penny and 1850s metal button.....	92
Figure 10-3. Selected container glass items from San Pedro Park testing.....	93
Figure 10-4. Glass weight (grams) from Test Units 1, 2, 3, 4, 5, 6, 7, and 10 by level.....	94
Figure 10-5. Selected ceramics recovered from San Pedro Park testing. Top row are Native American bone tempered sherds. Bottom row are various white wares, including two with a yellow glaze.....	96
Figure 10-6. Bone weight (grams) by level in Map 6 area (Test Units 1, 5, 6, and 10).....	97
Figure 10-7. Bone weight (grams) by level in Map 4 area (Test Unit 4).....	98
Figure 10-8. Chipped stone debitage counts by 10-cm level, Test Unit 2 (Map 3 area).....	105
Figure 10-9. Chipped stone debitage counts by 10-cm level, Test Unit 1 (Map 6 area).....	105
Figure 10-10. Chipped stone debitage counts by 10-cm level, Test Unit 4 (Map 4 area).....	106
Figure 10-11. Late Prehistoric points recovered from San Pedro Park testing.....	106
Figure 10-12. Late Archaic points recovered from San Pedro Park testing.....	107
Figure 10-13. Earlier point forms recovered from San Pedro Park testing.....	108
Figure 10-14. Selected Test Unit 4 bifacial tools, San Pedro Park testing.....	109
Figure 10-15. Selected formal tools from San Pedro Park testing.....	110

Figure 10-16. Selected bifacial tools and fragments recovered from San Pedro Park testing..... 111

Figure 10-17. Weight (grams) of edge modified tools recovered from San Pedro Park testing 112

Figure 10-18. Weight (grams) of cores recovered from San Pedro Park testing 112

Figure 10-19. Burned rock weight (kg) by level for Test Unit 4 113

Figure 10-20. Burned rock weight (kg) by level for Test Unit 1 113

Figure 10-21. Burned rock weight (kg) by level for Test Unit 10 114

Figure 10-22. Burned rock weight (kg) by level for Test Unit 5 115

Figure 10-23. Burned rock weight (kg) by level for Test Unit 6 115

Figure 10-24. Burned rock weight (kg) by level for Test Unit 13 116

Figure 11-1. A hypothetical MSS profile showing a buried surface 117

Figure 11-2. MSS values for profile in Test Unit 4..... 118

Figure 11-3. Test Unit 4 artifacts (left), profile (middle), and MSS values (right) by depth 119

Figure 11-4. MSS values for profile in Test Unit 5 120

Figure 11-5. MSS values for profile in Test Unit 10 120

Figure 11-6. MSS values for profile in Test Unit 2 121

Figure 11-7. MSS values for profile in Test Unit 7 121

Figure 12-1. Impact Zones identified in previous work (Zapata and Meissner 2003)..... 125

Figure 12-2. Kernel density plot of modern artifacts in shovel tests, Levels 1-3 (see Chapter 7)..... 126

Figure 12-3. Kernel density plots of modern material in shovel tests, Levels 1-3, from Zapata and Meissner (2003) and Houk (1999) 127

Figure 12-4. Proposed management areas within San Pedro Park 128

Figure A-1. Bison 1 standard dates (+/- 2 sigma range) 153

List of Tables:

Table 7-1. Counts of Cultural Material Recovered from Shovel Tests 50

Table 8-1. Artifacts Recovered from Test Unit 7 64

Table 8-2. Artifacts Recovered from Test Unit 3 65

Table 8-3. Artifacts Recovered from Test Unit 2 67

Table 8-4. Artifacts Recovered from Test Unit 4 69

Table 8-5. Artifacts Recovered from Test Unit 13 74

Table 8-6. Artifacts Recovered from Map Area 6 76

Table 8-7. Artifacts Recovered from Test Unit 10 81

Table 9-1. Artifacts Recovered from Test Units 8 and 9 89

Table 10-1. Ceramics Recovered from Test Excavations 95

Table 10-2. Identified Taxa 98

Table 10-3. Taxon Distribution within Test Units 99

Table 10-4. Debitage Cortex and Size for Test Units 104

Table A-1. Isotopic Results from Bone Selected for Radiocarbon Dating, 41BX19 152

Table A-2. Collagen Radiocarbon Results for 41BX19 and Bison 1 (Standard)* 153

Acknowledgements:

Many thanks go to the field crew that included Preston Beecher, Mark Luzmoor, Alex McBride, Tyrone Tatum, and Alex Wadley. Stephen Smith and Kristi Nichols directed the fieldwork. Sarah Wigley and Melissa Eiring completed the lab processing and summaries. Thanks to Kay Hinds, City Archaeologist with COSA, for her input, comments, and general direction. Kay provided invaluable comments on the initial draft of this document. Ray Smith of San Jacinto Materials, Inc. provided maps of San Pedro Park, literature, and other data. Thanks to Bill Pennell, Assistant Manager Park Planning, Parks and Recreation Department, COSA, and Barbara Fenlon for softball field access. Laurence Cavaness provided operation of the backhoe with Alamo Backhoe Services. Special thanks to Laura Carbajal, Rick Young, and Leonard Kemp for support with maps and other graphics. Thanks to Kelly Harris for editing the final manuscript. Thanks to David Calame, Cynthia Munoz, and Steve Tomka for help with artifact identification and presentation advice and to the folks at UTSA Special Collections for library assistance. Thanks to Brian Gottschalk and Sable Kitchen of Adams Environmental, Inc. for their support of this project.

Chapter 1: Introduction

Raymond Mauldin, Antonia Figueroa, and Stephen Smith

The University of Texas at San Antonio Center for Archaeological Research (UTSA-CAR) contracted with Adams Environmental, Inc. to provide archaeological services to Capital Improvement Management (CIMS) of the City of San Antonio (COSA) related to the investigation of selected archaeologically sensitive areas of San Pedro Springs Park in San Antonio, Bexar County, Texas (Figure 1-1). San Pedro Springs Park (41BX19) is a significant historic and prehistoric site. The 46-acre park is listed on the National Register of Historic Places (NRHP) and is a State Antiquities Landmark (SAL). As such, CAR's work was conducted under Texas Antiquities Permit No. 6727 issued by the Texas Historical Commission (THC). The archaeological investigation at 41BX19 took place from early December

2013 to mid-January of 2014. Dr. Steve Tomka served as Principal Investigator during the fieldwork, with Dr. Raymond Mauldin serving as Project Manager, and Steve Smith and Kristi Nichols serving as Project Archaeologists. Dr. Mauldin took over the permit responsibilities following Dr. Tomka's departure from UTSA. COSA initiated the archaeological investigation in anticipation of a series of improvements to San Pedro Park that should occur over the next few years. Funding for portions of the improvements may involve federal funds, and as such, the project potentially falls under Section 106 of the National Historic Preservation Act, and some of the improvements may affect San Pedro Park archaeological resources. At the time this investigation was conducted, the only impact identified was the establishment



Figure 1-1. The project area on a combined USGS 7.5-minute quadrangle map (San Antonio East and San Antonio West).

of a pedestrian trail system running along the extreme western side of the park, with small segments to the north and south. Nevertheless, the work conducted by CAR focused on the park as a whole, with attention to areas that had not been extensively disturbed by previous constructions.

The research goals of the investigations were to identify colonial and proto-historic deposits, including evidence of the first *acequia* (irrigation system) in the region, an associated dam, the location of the presidio, and villa, all founded in 1718. This work was partially intended to provide an investigation and archival research into the founding of the *Villa de Bexar* in advance of the 300th anniversary of the City of San Antonio in 2018. In addition, CAR strove to identify and investigate areas of intact prehistoric cultural deposits. To these ends, CAR staff initially conducted a review of previous archaeological work within the park (see Houk 1999; Meissner 2000a, 2000b, 2000c; Zapata and Meissner 2003) as well as a review of park uses. As can be seen in a 2013 aerial from Google Earth (Figure 1-2), various areas within the park have been extensively altered. These areas include most of the northeastern quadrant of the park, which consists of tennis courts, associated buildings and view stands, and parking areas, the San Pedro Playhouse and parking areas in the northwest quadrante, the swimming pool, bathhouse, and playgrounds in the central and southwest quadrante, and the baseball fields and parking areas in the southeast section.

Based on the reviews, CAR excavated 106 shovel tests across areas of the park, sampling all areas that were accessible. Most of these were concentrated on the western and southeastern sections. The results of these shovel tests, in combination with historic maps, was used to plan the locations for additional work. Seven different areas of the park were selected, with 11 1-x-1 m test units (TUs) excavated. Five additional shovel tests (n=111 total) were added, two narrow backhoe trenches were excavated, and a series of auger holes were placed at the bottom of several TUs. In addition, the Project Manager walked the proposed pedestrian trail segment along the northwestern, western, and southwestern edge of the park. No surface features or artifacts were observed in this area.

No clear evidence of colonial occupation was noted during the shovel testing. Due to various utility lines and obstructions, the plan to use backhoe trenches to search for the San Pedro *Acequia* and associated dam could not be implemented. Utility lines and the previous expansion of the swimming pool (see Houk 1999; Zapata and Meissner 2003) likely disturbed the areas planned for investigation for the probable location of the *acequia* and associated dam. Houk (1999:20) suggested that construction work after 1912 destroyed the colonial head gate, some of the

original *acequia* channel, and dam. CAR's plotting, using historic maps, suggests that the *acequia* may lie to the east of the modern sidewalk exiting the park to the south. Given that improvements are not currently planned in this area, a decision was made not to disturb the sidewalk or potentially damage any utility lines, and a 1-x-2 m trench to the west of the suspected path was excavated. There was significant disturbance in that trench. A portion of that excavation did reveal a gravel filled cut that is close to the anticipated general location of the San Pedro *Acequia*. The gravel appears to be modern fill rather than associated with fluvial activity, and a variety of construction and recent material, including aluminum pull tabs, sand bags, and asphalt, is mixed with prehistoric and mid-to-late-nineteenth- through mid-twentieth-century ceramics. Given current data, any definitive conclusion regarding the nature of this trench is not possible. It is possible, though unlikely, that it represents the remnants of the San Pedro *Acequia*. However, as discussed in a later chapter, it may be associated with a channel or trail identified on an 1870 City Engineering Map. It could also be associated with other, more modern construction.

Shovel testing and the excavation of test units revealed the presence of modern, historic, and prehistoric material throughout most areas of the park. Many shovel tests showed evidence of disturbance with a mix of modern, historic, and prehistoric cultural material, especially in the upper three levels (30 cm below the surface [cmbs]). However, there was an increase in prehistoric material associated at deeper levels. Shovel testing produced evidence of several potential features and defined areas with a high density of prehistoric material.

As no clear colonial deposits were identified in the shovel testing, subsequent testing focused on the distribution of prehistoric material and the potential location of the San Pedro *Acequia*. As noted above, two test units were excavated in an attempt to locate the *acequia*. As part of the background to that exploration, CAR staff reviewed a series of historic maps, including a detailed contour map created in 1899 by E.G. Trueheart just before the initiation of major renovations to the park. Newspaper articles document that the renovations in 1899 included the removal of large quantities of surface sediments from various areas of the park as well as their replacement with crushed limestone and other materials to improve surface conditions. These activities, which are clearly visible in several of the test units, probably removed a significant component of the Colonial, Proto-historic, and Late Prehistoric Period record.

Beyond the search for the colonial deposits in the south-central portion of San Pedro Park, testing focused on six other areas. The deposits in most of these areas were disturbed in the upper 30 cm.



Figure 1-2. *San Pedro Park in 2013. The current park boundary is outlined in orange. Original, underlying map image is from Google Earth.*

However, three areas tested had high densities of burned rock and other artifacts and, based on the current analysis, have units or levels with significant information potential. These are briefly summarized below, and details are presented in Chapters 8, 10, 11, and Appendix A.

The first area is located in the west-central portion of the park where four units were excavated. In this area, CAR staff defined a single burned rock feature (Feature 1) overlaid by a low-density layer of scattered burned rock spread over an area in excess of 90 m². Also present in these excavations were chipped stone debitage, bone, mussel shell, several Native American ceramics, historic and modern material, chipped stone tools, chipped stone cores, and scattered charcoal. The upper 50-60 cm of deposits across these units is mixed, with portions capped by an old road base. Below 60 cm, materials in several units seem to retain moderate integrity. Based on recovery of projectile points and other artifacts as well as three radiocarbon dates from a single unit, the lower material dates to the Late Prehistoric and the Late Archaic. One of the three dates, from near the bottom of the disturbed zone at 50-60 cmbs, was on bone collagen from a very large mammal consistent with bison. At 1-sigma, that sample (CAR 346)

returned several corrected, calibrated date ranges, a function of the relatively flat calibration curve late in time. The overall date range was from AD 1666 to 1942, with the most probable date range being from AD 1729 to 1778 (36.1%).

The second area is located in the southwestern quadrante, close to the anticipated pedestrian trail. In the single 1-x-1 m unit excavated, the upper 20 cm had a mixture of debitage, faunal material, glass, and a small amount of metal. A single Native American ceramic sherd was recovered in Level 2, and a moderate density of chipped stone debitage and burned rock was present in Level 3 (20-30 cmbs) along with faunal material and a Late Prehistoric (Edwards) point. A radiocarbon date (CAR 344) on collagen from bison bone recovered in Level 2 produced a corrected, calibrated date almost identical to CAR 346. The overall range at 1-sigma for this bison was AD 1670 to 1943, with the most probable range (36.6%) falling between AD 1730 and 1779. The date is in the level above the Edwards point and is associated with a single Native American ceramic. While this level also contained 36 fragments of container glass, and while a single piece of plastic was recovered from Level 3, the deposits in this area have potential to contain both Colonial and Late Prehistoric Period material.

The third area, located in the southeast section, was sampled initially with a single 1-x-1 m unit. The upper levels were disturbed, with a mixture of debitage, burned rock, glass, and metal present down to 50-60 cmbs. Below 50 cm, the unit produced an extremely high density of debitage and burned rock, with several points and tools. Though there is rodent disturbance and some movement of material, the points seem to be in rough stratigraphic order and suggest deposition over several thousand years, primarily during the Late Archaic, with potentially earlier material. Faunal material is also present in quantity. Two narrow backhoe trenches were excavated to better define this third area. The trenching and excavation revealed what is likely to be a trash midden used over multiple centuries and containing an estimated 600,000 pieces of chipped stone debitage, with faunal material, burned rock, ground stone, and other chipped stone tools present in significant quantities. Several pieces of fauna were processed for collagen in preparation for radiocarbon dating, but recovery was not sufficient. A single radiocarbon date was obtained from a small piece of wood charcoal collected in Level 9 (80-90 cmbs). That date (Beta 390003) produced a calibrated, corrected range at 1-sigma of AD 1281 to 1385, placing the sample in the Late Prehistoric. The recovery of a variety of Late Archaic projectile point forms, between 50-90 cmbs, including Castroville, Frio, Marcos, and Montell, as well as a Pedernales in Level 9, and a possible Guadalupe tool in Level 13, suggests this charcoal date may be out of context. As mentioned, extensive rodent disturbance is present in this area, and small amounts of modern building material were recovered from Levels 8 and 9, with a single piece collected from Level 14. In spite of some possible mixing, this area has significant information potential.

Based primarily on the review of previous work, park history, and on the shovel testing and test excavation results discussed here, CAR subsequently outlined three broad management areas for planning purposes in future investigations. Management Area 3 consists of locations significantly impacted by historic and modern construction, such as tennis facilities in the northeastern section and the central swimming pool with its associated facilities. It is highly likely that these

disturbances have destroyed or degraded any archaeological resources that are present down to 1.5 m below the existing surface. Management Area 2 includes most of the park and appears to be disturbed down to at least 30 cm. Here, CAR recommends that an archaeological monitor observe any impacts below 30 cm in depth. Finally, Management Area 1 includes locations where subsurface impacts should be avoided. These locations have, or are likely to have, intact cultural deposits containing features and artifacts that can make a significant contribution to the understanding of history and prehistory. Concerning the specific implementation of the proposed pedestrian trail along the northwestern, western, and southwestern edge of the park, CAR recommends that this be allowed to proceed provided there is minimal below ground disturbance.

Report Overview

This report consists of 12 chapters. Chapter 2 provides a detailed review of the project area, including information on current and past climates, geology, hydrology, soils, and biotic resources. A general overview of what is currently known about the prehistoric and historic developments in the region is given in Chapter 3, while Chapter 4 provides a detailed history of San Pedro Park. Chapter 5 summarizes previous investigations within the park area. Chapter 6 outlines the goals of the current project, as well as the field, laboratory, and curatorial methods used on the project. Chapters 7, 8, and 9 summarize the results of shovel testing, the excavation of test units and limited backhoe trenching, and the search for colonial water control features in the southern section of the park. Chapter 10 provides a summary of the major classes of artifacts recovered. Chapter 11 reviews the results of magnetic susceptibility samples that have implications for the integrity of the deposits investigated. Chapter 12 presents a summary and a series of recommendations regarding future park impacts as well as suggestions for the development of a public educational component within the park. Appendix A summarizes the radiocarbon results, while Appendix B provides information on some of the individuals who were at the *Villa de Bejar* in 1718.

Chapter 2: Project Setting

Stephen Smith, Cynthia Munoz, and Raymond Mauldin

This chapter presents an overview of the physical environment of the San Pedro Park project area, including information on climate, geology, hydrology, soils, floral and faunal resources, and paleoclimate. The park prehistory and history, discussed in more detail in Chapters 3 and 4, as well as the modern uses of the area are closely linked to the physical environment, with geology being of primary importance. It is the geological setting and the consistent water availability that are the primary reasons for this location being a favored site for human occupation for thousands of years.

Climate

San Antonio has a humid subtropical climate characterized by hot, humid summers and cool, dry winters (Taylor et al. 1991). Data in Bomar (1995:222) from 1961 through 1990 shows the average annual temperature at San Antonio was 79.5°F, with the warmest months being July (95.0°F) and August (95.3°F) and the coolest months being December (63.5°F) and January (60.8°F). The growing season averages roughly 275 days a year (Taylor et al. 1991:119). Rainfall is bimodal with peaks in May (4.22 in.) and September (3.41 in.), while December (1.51 in.) and January (1.71 in.) are

the driest months (Bomar 1995:230). The average yearly rainfall from 1961 through 1990 was 30.98 inches (Bomar (1995:230).

Annual rainfall totals are available for most years from 1871 through 2012 (National Oceanic and Atmospheric Association 2013). Figure 2-1 presents these data, with rainfall totals for three years (1876, 1883, and 1884) estimated. These data show that the wettest year in San Antonio over this 142-year period was 1973, when 52.28 inches of precipitation was recorded. The 1919 and 1957 years were also extremely wet. The driest year was 1917, with only 10.11 inches of rainfall (Figure 2-1). Also identified in the figure is the 1950s drought. There is, as the figure and the spread of the yearly totals indicate, substantial variability from year to year. This variability is likely related to the location of San Antonio at 29.5 degrees north latitude and the city's relatively close (ca. 225 km) proximity to the gulf coast. Global circulation patterns result in a high frequency of persistent, high-pressure systems at latitudes of about 30 degrees, and these systems tend to block or deflect storms, resulting in low overall rainfall (Wallen 1966:31-33). Wallen (1966) notes that in both hemispheres latitudes around 30 degrees are associated with some of the largest deserts on Earth.

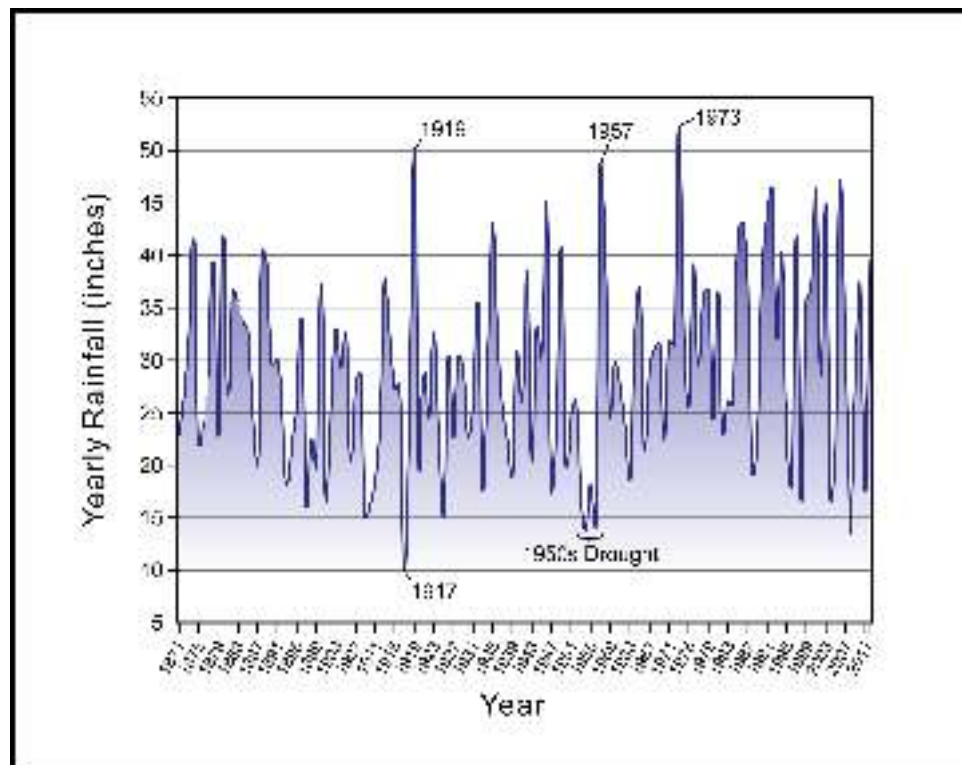

Figure 2-1. Annual precipitation in San Antonio (1871-2011).

While dry periods are common, San Antonio's proximity to the coast is such that severe storms, often associated with gulf coast tropical storms or hurricanes, can produce large rainfall totals over a short period. These gulf storms can result in substantial flooding (see Miller 2012). This pattern of gulf coastal storms producing extreme rainfall totals includes the 1921 flood that was devastating for much of south central Texas, including San Antonio (see Ellsworth 1923). Yet, as shown in Figure 2-1, 1921 was not an abnormal year in terms of rainfall.

While there are no instrument data available prior to 1871, the variability seen in the modern records is clearly shown in tree-ring data that for the San Antonio area stretches back to the close of the prehistoric sequence (see Cleaveland et al. 2011; Cook and Krusic 2004; Mauldin 2003a). The tree-ring data sets often rely on the Palmer Drought Severity Index (PDSI). Developed in the early 1960s, the PDSI is a relative measure of soil moisture calculated from rainfall, temperature, transpiration, potential evaporation, soil type, and runoff values (Alley 1984; Karl 1986). The index frequently ranges from highs around a value of 4, indicating a severe wet spell, to those of -4, indicating severe drought. A value of 1 to -1 indicates a normal moisture period. The PDSI values used here are reported by Mauldin (2003a) and rely on data developed by Cook et al. (1999; see also Cleaveland et al. 2011). Figure 2-2 presents the PDSI from AD 1700 through 1799 for the San Antonio region, with Figure 2-3 showing the 1800 to 1899 pattern and providing an overlap with Figure 2-1. As with the Figure 2-1 instrument data shown previously, there is considerable year-to-year fluctuation in precipitation measurements on these two graphs. Certain periods, such as from 1717 through 1748 and 1865 through 1885, are dominated by higher moisture with only brief droughts, while other periods, such as from 1772 through the early 1790s and 1820 through 1864, were predominantly in drought.

The impacts of these periods of prolonged wet or dry cycles on the flow rates for regional springs fed by aquifers, such as San Pedro Springs, are difficult to judge. As discussed below, San Pedro is one of several springs that serve as outlets for rainfall that percolates through limestone-dominated uplands to the north across the Edwards Plateau. As such, the flow rates at these springs should buffer localized precipitation differences. Prolonged, regional droughts, such as the early 1950s drought (see Figure 2-1) which was one of the more severe and well documented dry periods in Central Texas (Bomar 1995; Cleaveland et al. 2011; Porter 2011), clearly affected flow rates of springs throughout the region. However, this impact was after historic and modern land use practices, including widespread pumping of water from the aquifer, had been in effect for decades. These practices likely reduced water storage and made the aquifer system vulnerable to extreme droughts.

Geology and Hydrology

The project area of San Pedro Park is located on the edge of the Balcones Fault Zone, just below the Edwards Plateau (Figure 2-4). During the Cretaceous Period (66-144 million years ago), shallow seas covered much of south Texas, including the project area. As calcareous animals died and sank to the sea floor, thick layers of limestone formed that gradually built immense sedimentary rock formations (Spearing 1991). Tectonic plate movement resulted in the uplift of the Edwards Plateau (Figure 2-4), the development of northeastward trending faults, and the subsidence of the Gulf of Mexico (U.S. Geological Survey 2014a). Karst uplands, formed by the dissolution of soluble rocks, including limestone and dolomite, typically are landscapes made up of caves and sinkholes containing large aquifers, such as the Edwards Aquifer (U.S. Geological Survey 2014b). As shown in Figure 2-4, varieties of limestone-dominated deposits are present in Bexar County, especially in the northern portion. Water percolates through these Cretaceous limestone deposits, which extend across the uplands, and flows into the Edwards Aquifer. Eventually, this water flows out into springs, creeks, and rivers (Barker et al. 1994).

Figure 2-5 shows the bounds of the Edwards Aquifer and identifies three of the more prominent springs. These are San Marcos Springs along the San Marcos River, Comal Springs along the Guadalupe River, and San Pedro Springs, the headwaters of San Pedro Creek. San Pedro Creek flows approximately eight kilometers to the southeast before merging with the San Antonio River, itself formed by an outflow from the Edwards Aquifer, and then continuing to the Gulf of Mexico (Donecker 2014; Texas Parks and Wildlife Department [TPWD] 2014). Note that these springs and creeks, as well as several other outflow points, tend to be located along the eastern edge of the artesian zone in Figure 2-5. While there are historical patterns of exposure, erosion, and uplift that account for this pattern, the principal reason for the location of the springs along this edge is that the aquifer is at a lower elevation in this area. Consequently, while historic and modern water pumping strategies have depleted the aquifer, these springs have provided a relatively reliable source of high quality water, even in drought conditions, as they are the endpoints of a much larger and more complex drainage and outflow system (see Woodruff and Abbott 1986).

While spring flow is variable at present, the springs at San Pedro flow primarily from a limestone bluff near the center of the modern park. The bluff is associated with a fault line. Figure 2-6 shows the park's bedrock geology in more detail. Upper Cretaceous age chalks and marls, including Austin Chalk (Kau) and a small amount of Pecan Gap Chalk (Kpg), dominate the northern and western portions of the park, with

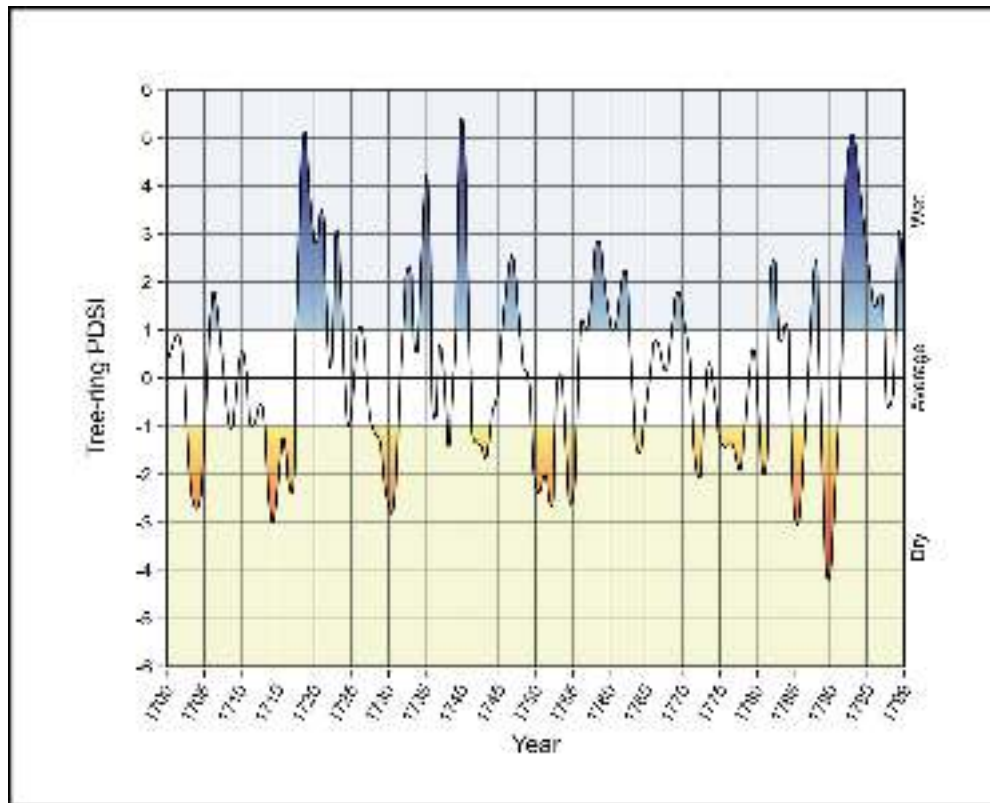

Figure 2-2. Tree-ring based PDSI values for San Antonio Region, 1700-1799 (after Mauldin 2003a).

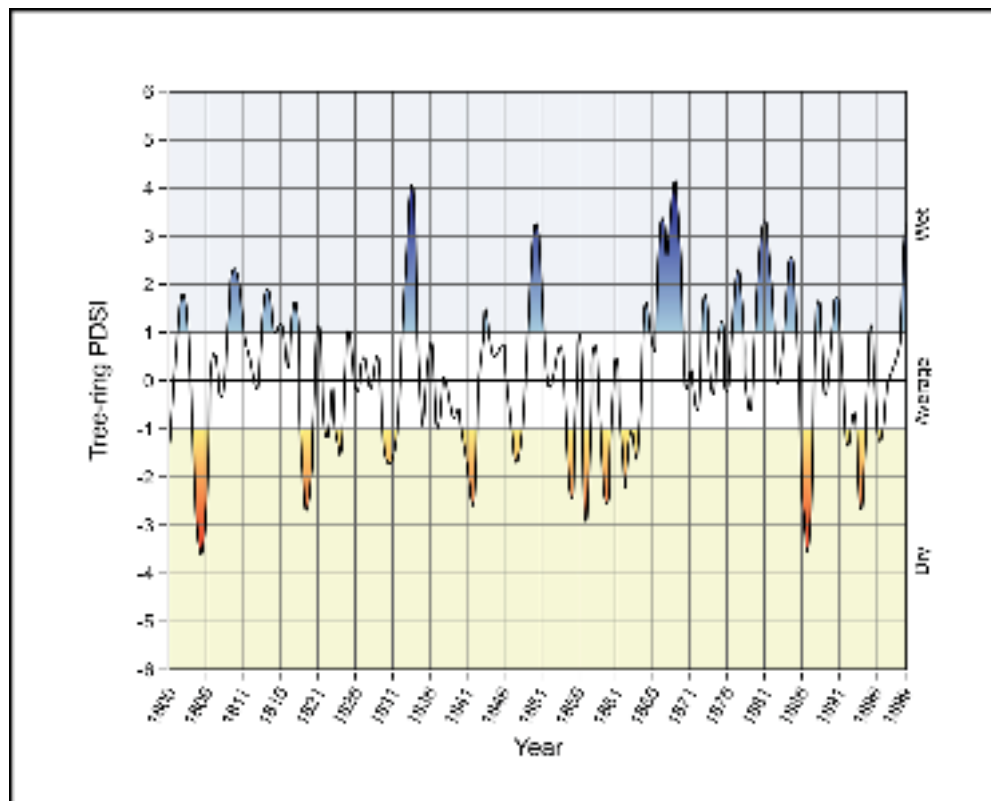

Figure 2-3. Tree-ring based PDSI values for San Antonio Region, 1800-1899 (after Mauldin 2003a).

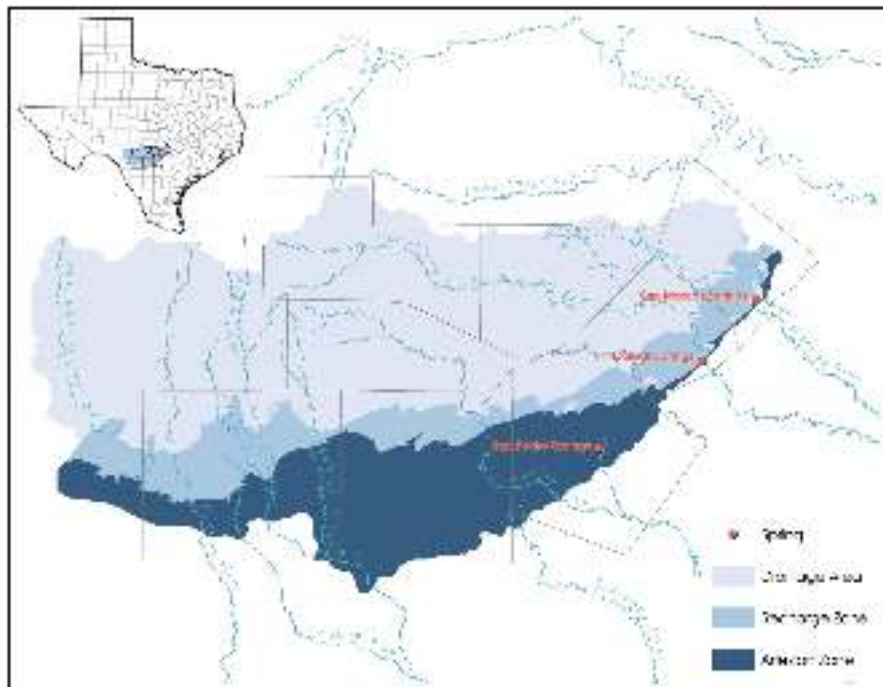

Figure 2-5. Edwards Aquifer with major divisions, springs, and associated rivers (after Eckhardt 2014).

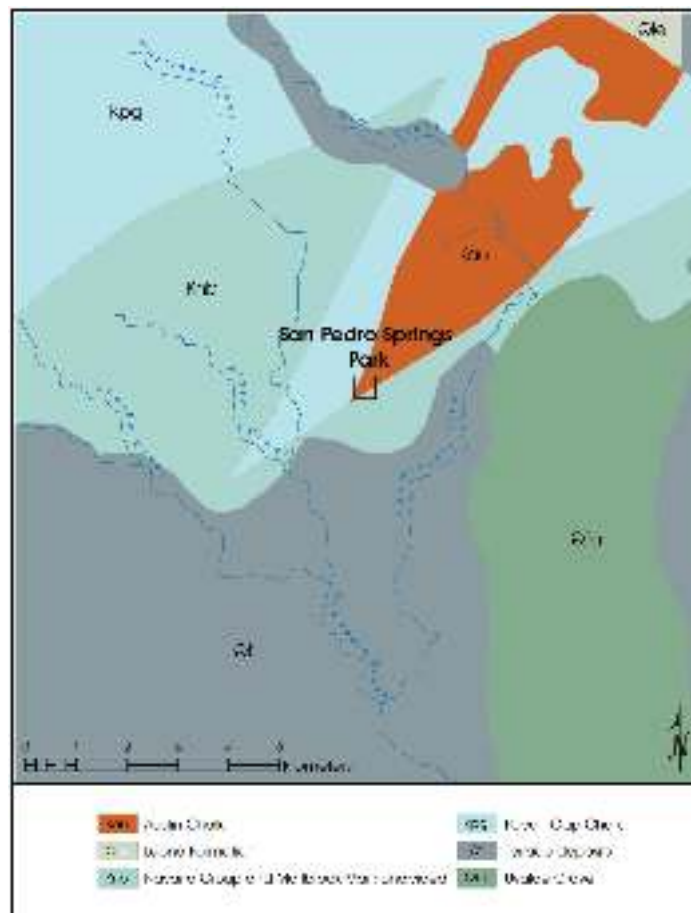

Figure 2-6. Geology of San Pedro Park Region (after Barnes 1983).

Biotic Zones and Floral and Faunal Resources

The project area is at the intersection of several ecological zones. As shown in Figure 2-8, the Edwards Plateau/Balcones Canyonlands is to the north, with the northern end of the Texas Plains and the southern end of the Post-Oak Savannah Zone present to the south (TPWD 1984). The Blackland Prairie cuts across much of the center of Bexar County and encompasses San Pedro Springs. Prior to urbanization, these zones would have provided a variety of floral and faunal resources for human consumption and use. The following summary, which discusses vegetation resources prior to urbanization, relies on descriptions provided by the TPWD (1984; 2014), as well as summaries by Gould et al. (1960), Griffith et al. (2004), Metz (1931), and Turner et al. (2003).

The Balcones Canyonlands is a specific section along the southeastern edge of the Edwards Plateau. It is to the north of the current project area (Figure 2-8). A variety of vegetation is present in this zone, including many different species of trees. On the plateau, Texas mountain laurel and species of oaks and maple are present. Willows are common along major streams. As aridity increases, shrub vegetation,

including juniper and mesquite, are increasingly common with acacia, sotol, and prickly pear observed in settings that are more arid. The Blackland Prairie region, dominated by urban development in the current area, would have contained grass species, including little bluestem, big bluestem, dropseed, gamagrass, and switchgrass. While trees are less common here than in the Balcones Canyonlands, elm, ash, cottonwood, hackberry, pecan, and several variety of oaks are present. The South Texas Plains is dominated by mesquite, live oak, and juniper, with several grasses, including little bluestem and sideoats grama grass. Scattered brush and shrubs dominate the landscape, with a variety of succulents present. Larger tree species are confined to riparian settings, with hackberry, oak, pecan, cottonwood, and elm present at low densities. Finally, a small section of the southern end of the Post Oak Savanna is present in the southern portion of Bexar County (Figure 2-8). This zone is dominated, as the name suggests, by post oak with mesquite, juniper, and several types of shrubs present (Griffith et al. 2004; Turner et al. 2003).

Currently, bobcat, cottontail rabbit, coyote, fox, jackrabbit, raccoon, skunk, squirrel, white-tailed deer, and a variety of other smaller mammals are present, along with fish, reptiles, and birds, including turkey (Blair 1950; Davis and Schmidly

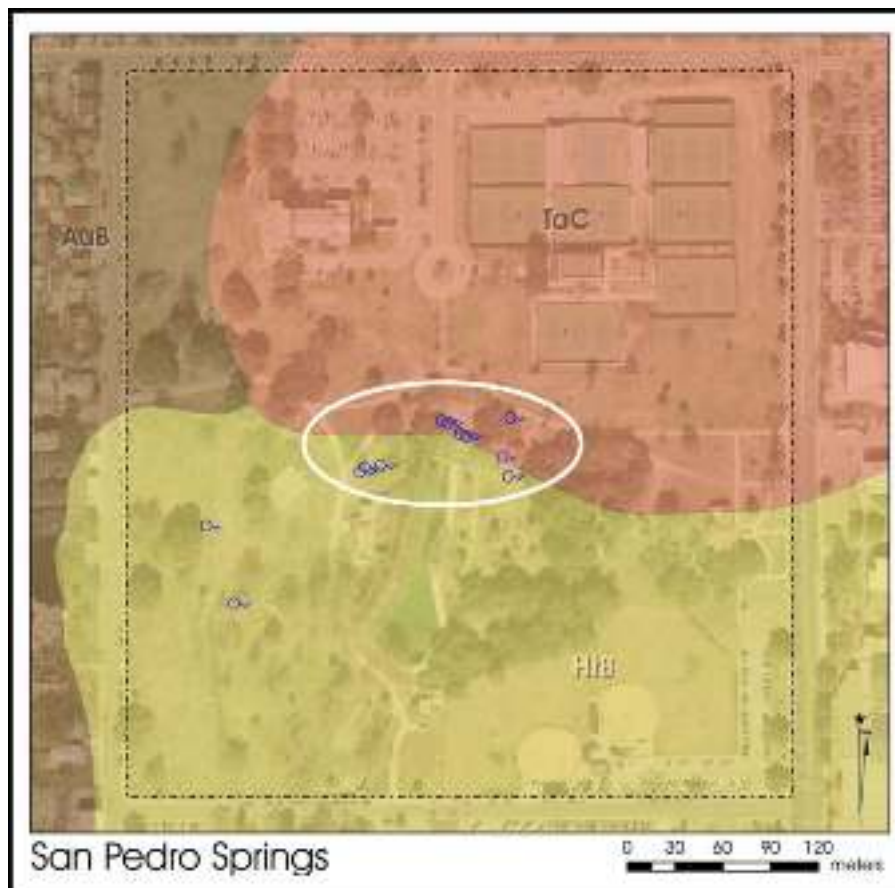

Figure 2-7. Soils in San Pedro Park (NRCS 2014) with major springs identified (Brune 1981). Base map is an aerial photograph from ESRI.

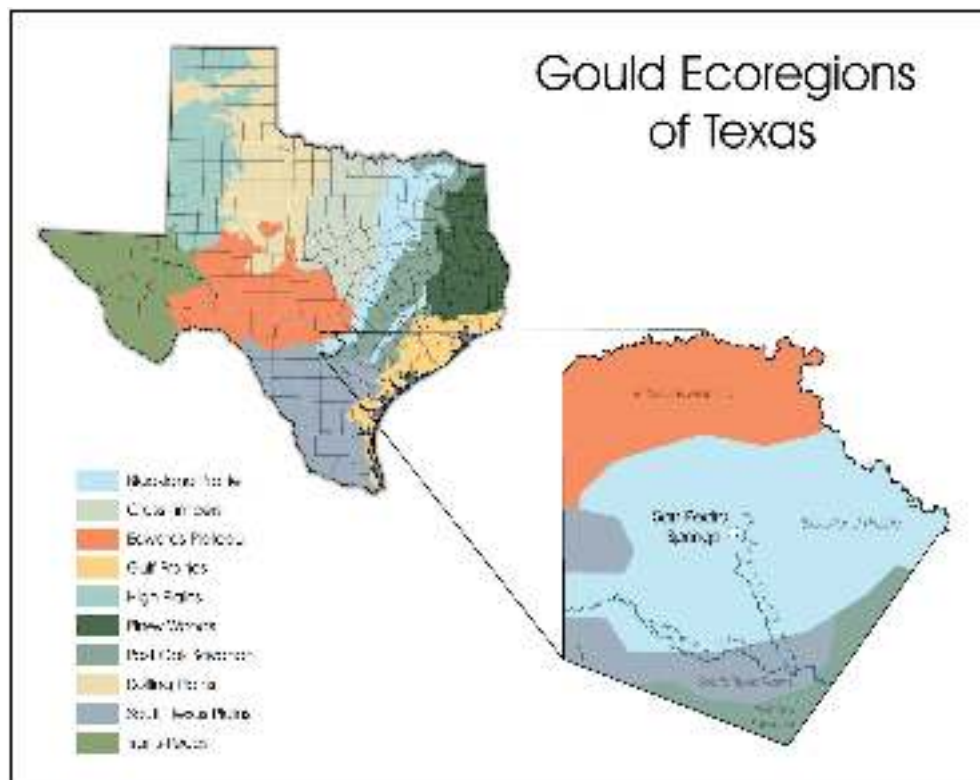

Figure 2-8. Ecoregions of Texas with a focus on Bexar County (TPWD 2014).

1997). Prior to population growth and significant land use changes in the late nineteenth and early twentieth century, bison, pronghorn antelope, and black bear were present in the area (David and Schmidly 1997; Wade 2003; Weniger 1997).

Paleoenvironment

The above discussion provided a brief overview of modern and historic biotic and abiotic conditions surrounding the project area. While several of these can be treated as constant for the period of interest, some, such as climate parameters and associated shifts in floral and faunal resources, clearly changed at several temporal scales over the historic and prehistoric time span. Understanding of these past environmental changes in Central Texas in the Holocene is derived from climate studies that rely on various proxy data. These proxy data range from changes in the frequency of shrews to the presence/absence of bison (e.g., Collins 2004; Dillehay 1974; Toomey 1993), shifts in pollen frequencies (Bousman 1998), and changes in isotopic parameters in soils and snails (Cooke 2005; Munoz et al. 2011a, 2011b; Nordt et al. 2002; Smith et al. 2014). These data sets tend to respond to shifts in precipitation and temperature in radically different ways at variable time scales, making comparisons between data sets difficult.

Here the focus is on a series of long-term data sets, two of which are based on changing pollen frequencies and two of which are based on stable carbon isotopic shifts in response to changes

in local vegetation. While these data sets are not ideal, they were selected primarily because they have significant temporal depth and have independent dates in most cases. The pollen data sets are from a combined series at Boriack and Weakly bogs (Bousman 1998) and a second series from Patschke bog (Camper 1991; Nickels and Mauldin 2001). These are located to the northeast of San Pedro Springs, with the major data sets being roughly 180 kilometers away. The two isotopic data sets are from Medina River (Nordt et al. 2002), in southern Bexar County, and from Hall's Cave (Cooke 2005), a well dated sinkhole in Kerr County on the Edwards Plateau roughly 100 kilometers to the northwest of San Pedro Springs. Figure 2-9 presents these data.

The two carbon isotope data sets (1 and 2 in Figure 2-9) show a generally similar pattern. The Medina River paleosols (Nordt et al. 2002) have values reflecting a low, C_3 dominated vegetation structure during the initial Paleoindian and Early Archaic Period up to roughly 7200 BP. This would primarily reflect a high density of trees and shrubs, with low densities of grasslands, which have a C_4 vegetation pattern. The isotopic pattern from Hall's Cave sediment (Cooke 2005) on the Edwards Plateau to the north and west of the project area shows a similar overall pattern, with stable or declining C_3 vegetation into the Middle Archaic. The sequences then diverge with an increase and small peak in C_4 , probably indicating grasslands, present in the Medina sequence at

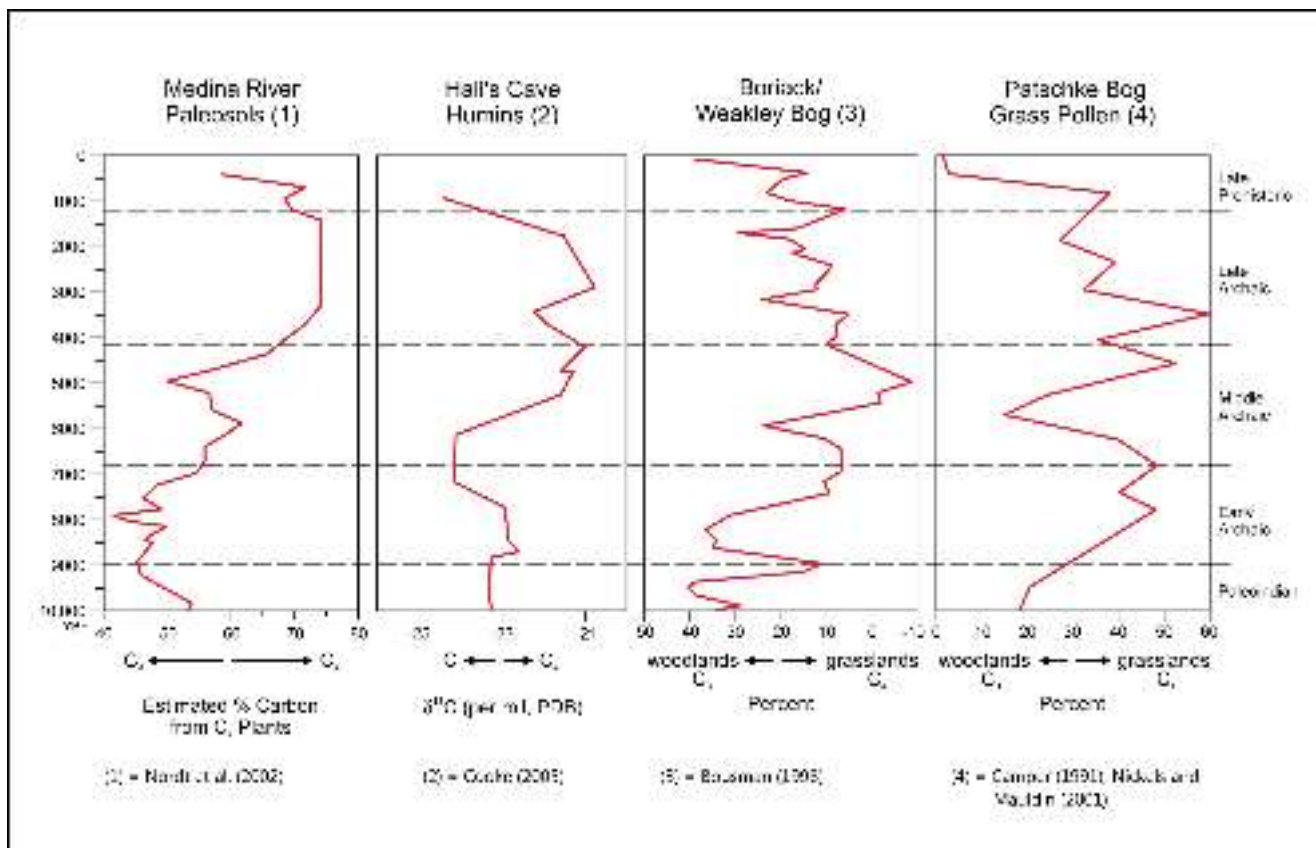

Figure 2-9. Long term, regional climate sequences for Central Texas.

around 6000 BP. This is followed by increase C_3 through 5000 BP, and then a gradual increase and stability of C_4 vegetation through the Late Archaic. The Hall's Cave sequence also shows an overall shift towards C_4 grass but without the Middle Archaic shift to C_3 at 5000 BP shown in the Medina. The Medina sequence shows a decline in C_4 grass at the close of the Late Archaic. That decline accelerates near the end of the Late Prehistoric Period. The well dated Hall's Cave sequence also shows a sharp decline in C_4 vegetation in the Late Prehistoric Period. This late decline is initiated at around 1200 BP in the Medina River and a few hundred years earlier, around 2000 BP, in the Hall's Cave sequence (Figure 2-9).

Data from the two pollen sequences (3 and 4 in Figure 2-9), while variable, suggest that arboreal vegetation was dominant at 10,000 BP, near the close of the Paleoindian Period. Variable but increasing grass pollen, possibly suggesting drier, warmer conditions, was present until roughly 7500 or 7000 BP throughout much of the Early Archaic. At that point, a shift back to arboreal vegetation is indicated. After about 6000 BP in the Middle Archaic, grassland again increased, peaking at about 5000 BP at Boriack and around 3500 in the Patschke sequence. After these peaks, the Figure 2-9 data show that grass pollen in both sequences decline, a decline

that continues throughout the Late Archaic and into the Late Prehistoric and Proto-historic/Historic Period.

Summary

The hydrogeology of San Pedro Springs provided a relatively consistent source of high-quality water in the form of several springs that, prior to the late nineteenth century, likely flowed throughout the year in spite of high year-to-year variation in local rainfall. Prior to urban expansion and resulting dramatic shifts in the ecosystem, it is likely that the springs were a source of water even in periods when multi-year droughts were present, though the precise impacts of long-term drought on spring flow remains unknown. Within the surrounding region, the presence of several different ecological zones in relatively close proximity provided a diversity of plant and animal resources for human use. Chert raw materials were not present in the immediate project area, though large quantities of high-quality cherts were available to the north along the Balcones Escarpment and as secondary nodule deposits to the south and east. While the springs located at San Pedro were not unique to the Central Texas area, they like a handful of other locations along the eastern side of the Edwards Aquifer (e.g., San Marcos Springs/Spring Lake area; see Hooge 2013) provided critical resources to occupants in the region for thousands of years.

Chapter 3: Cultural Environment

Raymond Mauldin, Cynthia Munoz, Antonia Figueroa, and Clinton McKenzie

This chapter provides a description of the culture setting of the study area. Not surprisingly, the presence of a high-quality water source that was consistently available, even during dry periods, has made San Pedro Springs a favored location for hunters and gatherers, Spanish missionaries, historic travelers, San Antonio residents, and entrepreneurs. The subsequent chapter provides details of the park history and use. This discussion focuses on the regional pattern of prehistoric, proto-historic, colonial, and historic developments. Within the prehistoric sequence for the current project, there is clear evidence that the park was used during the Late Archaic and the Late Prehistoric Period, as well as suggestions of use during the Middle Archaic and potentially earlier periods. Previous research and material from private collectors has documented Early Archaic point forms in the park (Wadley and Tomka 2013). There is also reference to Paleoindian forms being recovered, but only a single point, possibly reworked and identified as a Late Paleoindian “Orchard” point, could be found in the literature review (see Meissner 2000a). Evidence for colonial use of the location, at least in terms of artifacts recovered on the current project, is minimal. A handful of bone tempered Native American sherds were recovered that could date to this period, though they also may be earlier. In addition, two radiocarbon dates on bone, one from a bison and a second from a cow-sized animal, probably fall within this period (see also Meissner 2000a). However, as discussed in subsequent chapters, secondary archival sources and translations of primary documents (e.g., Hatcher 1932; Tous 1930a, 1930b) provide ample evidence of colonial use of the location. That evidence is extensively discussed in the following chapter.

Prehistoric Background

San Pedro Park is located in the Central and South Texas archaeological regions (see Collins 2004; Hester 1989; Prewitt 1981). The discussion of this region relies primarily on the work of Collins (2004; see also Bousman et al. 2004; Johnson and Goode 1994) for Central Texas and Black (1989) and Hester (2004) for areas to the south of the site. The prehistoric sequence is discussed using three broad temporal periods (Paleoindian, Archaic, Late Prehistoric), each of which is subdivided into smaller blocks based primarily on point styles. Often, these point distinctions are supported by stratigraphic superposition and chronometric dates (see Black 1989; Bousman et al. 2004; Collins 2004; Johnson and Goode 1994; Prewitt 1985). For many researchers in Texas, these point styles and shifts through time reflect cultural distinctions. That is, specific point styles (e.g., Perdiz, Langtry) are associated with a specific cultural groups (e.g.,

Johnson 1994; Johnson and Goode 1994; Prewitt 1981, 1985; Shafer 1977). These distinctions are used to discuss temporal relationships. No cultural distinctions are implied or assumed. Whenever possible, radiocarbon dates are used, and dates are reported as roughly equivalent to calendar years. Dates reported here, as well as the overall time scheme, use the before present (BP) convention.

Paleoindian Period (13,000-9000 BP)

As summarized by several researchers (e.g., Bousman et al. 2004), the Paleoindian Period can be subdivided into an Early and a Late sub-period, with the initial period covering roughly 2,000 years. While claims for earlier occupations in Central Texas are increasingly well supported (see Collins 2003; Waters et al. 2011), Clovis material, assigned to the Paleoindian Period, represents the earliest occupations for the region that are widely accepted by most researchers at present. Diagnostic projectile points from this Early sub-period include fluted Clovis and Folsom types, as well as other lanceolate-shaped point types (e.g., Plainview). Late Paleoindian forms included lanceolate-shaped, unfluted points (e.g., Golondrina/Barber, St. Mary’s Hall) and several stemmed forms such as Berclair, Big Sandy, San Patrice, and Wilson (see Bousman et al. 2004; Collins 2004).

Clovis points are widely distributed across much of North America, and information on lithic technologies (see Bradley et al. 2010; Collins 1999a) and adaptive patterns (Bonnichsen and Turnmire 1991) are available. Over 500 Clovis points have been recorded in Texas (Bever and Meltzer 2007). Many of these are recovered as isolated artifacts rather than being clustered on archaeological sites. Several well known Clovis sites are recorded, however, including Aubrey (Ferring 2001), Gault (Collins 2003, 1999b; see also Jennings 2012), and, in Bexar County, Pavo Real (Collins et al. 2003). Clovis adaptations were thought to reflect a specialized, highly mobile adaptation focus on hunting extinct megafauna, including mammoth, mastodon, and bison (e.g., Wormington 1957). Recent faunal data suggest the exploitation of a greater diversity of small- and medium-sized mammals and reptiles (e.g., Collins 2003:9) with some sites (e.g., Gault) representing a generalized adaptation. Nevertheless, an analysis of 33 Clovis age faunal assemblages by Waguespack and Surovell (2003) showed that extinct megafauna were consistently present on these sites.

Folsom occupations follow Clovis, and Folsom does appear to be a more specialized adaptation focused on the exploitation

of bison (*Bison antiquus*). Folsom components have a limited spatial distribution relative to Clovis, with the former primarily located near grasslands and in basin and range settings (see Andrews et al. 2008). Largent (1995; Largent et al. 1991) reports distributional data on 345 points recovered from 63 of the 254 Texas counties, with most recovery in the Southern Panhandle, South, and West Texas. Bonfire Shelter, located in South Texas (Bement 1986; Dibble and Lorrain 1968) and the Lubbock Lake (Johnson and Holliday 1989), Lipscomb (Hofman 1995), and Plainview sites (Speer 1990) in the Texas Panhandle, are well known occupations that contain Folsom material. Jennings (2012; see also Waters et al. 2011) reports the recovery of about 18,000 Folsom age artifacts at the Debra L. Friedkin site located near Gault in Bell County. Collins et al. (2003) report data on Folsom assemblages at Pavo Real (41BX52).

Late Paleoindian materials, tentatively dated from 11,000-9000 BP, have a variety of new point types present. As noted previously, in Texas Late Paleoindian point forms include Golondrina/Barber, Scottsbluff, and St. Mary's Hall, as well as several stemmed points forms (see Bousman et al. 2004). The distribution of any single Late Paleoindian point type is more limited when compared to those dating in the Early Paleoindian Period. There is also a greater diversity of point forms. When combined with the limited spatial data, this diversity may reflect lower overall mobility and an emphasis on local resources (see Anderson 1996). Research on the Late Paleoindian material from the Wilson-Leonard site in Williams County, Texas, (Collins 1998), seems to be consistent with the notion of a more diverse diet. Other well known sites with Late Paleoindian material directly related to subsistence include the Angostura material from the Richard Beene site in southern Bexar County (Thoms et al. 1996; see also Chadderdon 1983; Hester 1983, 2004; Johnson 1987).

Archaic Period (9000-1200 BP)

Relative to the preceding Paleoindian Period, the 7,800 year Archaic Period reflects increased population, an intensification of hunting and gathering, lower mobility, and an associated focus on the use of increasingly local resources. In the Central Texas area, a variety of technological changes, some of which are clearly related to subsistence and a shifting resource structure, appear during this period. These include the extensive use of rock as heating elements in cooking hearths (see Black and McGraw 1985; Collins 1995, 2004), the expansion of ground stone technology, and continued diversification and specialization in chipped stone technology (Collins 2004; Hester 2004; Johnson and Goode 1994; Turner and Hester 1999). Associated changes in mobility and organization include the founding of large cemeteries and more restricted spatial distribution on point types, both of which may signal the development of territories (Black

and McGraw 1985). Researchers commonly subdivide the Archaic into three broad sub-periods designated Early, Middle, and Late (e.g., Collins 2004; see also Johnson and Goode 1994). The divisions are somewhat arbitrary, and the beginning and end dates, as well as associated diagnostics, fluctuate among researchers.

Early Archaic (9000-6800 BP)

The Early Archaic is defined by a series of new point types, including Early Split Stem/Early Triangular, Gower, Martindale, and Uvalde (Collins 2004). These tend to be corner or basally notched forms (see Turner and Hester 1999). Beyond the specific point types, a series of what appear to be specialized tools, including Guadalupe bifaces and Clear Fork gouges (Turner and Hester 1999), appear during this time, as do new processing facilities, such as burned rock middens (e.g., Acuna 2006; Collins 1998). These shifts all hint at differences in subsistence, settlement, and overall organization relative to the earlier Paleoindian Period.

Well known sites that contribute directly to the understanding of the Early Archaic include the Richard Beene in southern Bexar County (Thoms et al. 1996), Wilson-Leonard to the north (Collins 1998), Buckeye Knoll on the coastal plain, and several sites on the Edwards Plateau (e.g., Gatlin site, Houk et al. 2009; Oksanen 2008; Vargas site, Quigg et al. 2008). Cave and shelter sites, primarily from the Lower Pecos, also have added critical data, especially in terms of resource use (see Riley 2008, 2012; Turpin 2004). Summaries by Weir (1976) and Story (1985) suggest that Early Archaic groups were highly mobile and potentially organized in small groups. Population density is assumed to have been low, and subsistence was based on a broad range of resources, including a variety of fauna (e.g., bison, deer, rabbits, rodents, and fish) and evidence for plant resources, including prickly pear, agave, and geophytes (Collins 2004; Hester 2004).

The Early Archaic is the first temporal distinction for which there is direct evidence on subsistence, at least for a few individuals, through the isotopic analysis of human bone. Bement (1994), working at Bering Sinkhole (41KR241) in Kerr County, reports stable carbon isotopes from collagen, which monitors protein intake, and carbonate, which monitors carbohydrates and protein, from two individuals that fall near the end of the Early Archaic time frame at 7050 to 6780 BP. These data average a -14.3‰ for $\delta^{13}\text{C}$ in collagen and a -6.6‰ for carbonate. This is consistent with a moderate reliance on plants (e.g., cactus, agave) and animals that used the CAM or C_4 photosynthetic pathway to process carbon (e.g., bison) and with a low dependence on C_3 resources such as sotol, deer, and acorns (Bement 1994; see also Bousman and Quigg 2006; Mauldin et al. 2013). This isotopic picture

contrasts, somewhat, with what has been presented based on archaeological material. This is especially the case with the C_4/CAM collagen signatures. Though derived from a sample size of only two individuals, the $\delta^{13}C$ from collagen suggests some dependence on C_4/CAM feeding animals, with the principal candidate in this region being bison. However, researchers have suggested that bison were not present during this period in this portion of the state (Collins 1995, 2004; Dillehay 1974). Other dietary sources may account for this difference, or bison may be present at this time.

Middle Archaic (6800-4200 BP)

A variety of new projectile point styles are defined for the Middle Archaic in Central Texas. These include Andice, Bell, Calf Creek, La Jita, Nolan, Taylor, and Travis point types (Turner and Hester 1999). The early portion of the Middle Archaic also is characterized by what appears to be a more specialized biface technology, with thin, triangular bifaces common, especially in the context of the early point forms such as Andice, Bell, Calf Creek, and Taylor point styles (Black 1989; Collins 2004; Johnson 1995). Nolan and Travis point types (Black 1989; Collins 2004; Johnson 1995) reflect the close of the Middle Archaic. Well known sites that have shaped the understanding of Middle Archaic adaptations in the region include the Gatlin site (Houk et al. 2009; Oksanen 2008), Jonas Terrace (Johnson 1995), and the Granberg site (Munoz et al. 2011a), the latter located in Bexar County.

Some (Collins 2004; Johnson 1995; Johnson and Goode 1994) suggest the shifts in point styles during the early portion of this period reflect the movement of populations into Central Texas from North Texas, Oklahoma, and Arkansas with a more specialized lithic technology perhaps geared to bison hunting. Collins (1995, 2004) suggests that bison are present during the period when Andice, Bell, and Calf Creek points are present but that bison are absent during the latter portion of the Middle Archaic. Dillehay (1974), however, finds no such presence during the Middle Archaic in his earlier review. In a recent review of presence/absence data from Central and South Texas, Munoz and Mauldin (2011:105-117) found bison were present on 3 of 13 early Middle Archaic sites (23%), consistent with Collins' (1995) suggestions, but also found that bison were recovered on 5 of 19 (26%) late Middle Archaic sites.

Most researchers, following Weir (1976; see also Story 1985), suggest human populations in the region increased during the Middle Archaic, a suggestion that may be derived from an increase in the number of components assigned to this period (Weir 1976). Note, however, that Collins (2004) suggests the intensity of occupation, especially in the early portion of the Middle Archaic, may have been reduced relative to earlier and later periods, implying higher mobility, especially early in the Middle Archaic.

Subsistence during the early portion of the Middle Archaic is said to involve the exploitation of bison, along with a variety of plant resources (see Black 1989; Collins 2004; Johnson and Goode 1994; but see also Dillehay 1974). Several researchers (e.g., Weir 1976) suggest that during the latter portion of the Middle Archaic, there was an expansion of oak in Central Texas that resulted in intensive acorn gathering by large groups, as well as the processing of acorns in burned rock middens (see also Creel 1986). Others (e.g., Acuna 2006; Black et al. 1997; Freeman 2007; Goode 1991; Mauldin et al. 2003) question this association between acorns and burned rock middens. Black et al. (1997), for example, suggest that the burned rock middens, initially used in the Early Archaic, did begin to accumulate in the Central Texas region during this period. However, they suggest these features were not focused on acorn processing. Rather, they argue that these features were used to bake a broad range of plants, including nuts, bulbs, and roots, as well as animal resources.

Isotopic data is available for 11 Middle Archaic individuals. Seven of these are from the work of Bement (1994) at 41KR241, and four are from recent work at Hitzfelder Cave in northern Bexar County (Munoz et al. 2013). Three of the 11 fall in the early portion of the Middle Archaic, dating to between 6500 and 5940 BP, and the remaining eight date near the close of the Middle Archaic, between 5100 and 4200 BP. The pattern in the early period is similar to that seen at the close of the Early Archaic. The three individuals average a -14.9‰ for carbon in collagen and a -7.6‰ for carbon in carbonate. The pattern for the late Middle Archaic individuals, however, shows a moderate move towards C_3 plants and animals, with average values of -16.6‰ and -9.2‰ for carbon from collagen, tracking protein intake, and carbonate, tracking whole diet. The higher C_3 intake is consistent with a move towards deer and away from bison and with an increased use of plants such as geophytes and sotol.

Late Archaic (4200-1200 BP)

The final interval of the Archaic in Central Texas is the Late Archaic. Wide varieties of dart points are present in this sub-period. Styles common in the Central Texas area include Bulverde, Castroville, Darl, Ensor, Fairland, Frio, Kinney, Marcos, Marshall, Montell, Pedernales, and Williams (Collins 2004). In addition to these point styles, corner-tanged knives, biface caches, marine shell ornaments, and cylindrical stone pipes characterize the sub-period (Collins 2004; Hall 1981; Hester 2005). In Central Texas, Johnson and Goode (1994) divide the Late Archaic into two smaller units, termed Late Archaic I (ca. 4300-2500 BP), characterized by Bulverde, Castroville, Marshall, Montell, and Pedernales points, and Late Archaic II (ca. 2500-1350 BP), characterized by Marcos and later styles. The sub-period is well represented by excavated sites, including the Anthon site (Goode 2002), Loeve-Fox (Prewitt 1974), Panther Springs (Black and

McGraw 1985), the Bessie Kruse site (Johnson 2000), Onion Creek excavations (Ricklis and Collins 1994), and sites in the Lower Pecos (Turpin 2004) such as Bonfire Shelter (see Dibble 1965; Dibble and Lorrian 1968).

Clear evidence for the wide-spread use of San Pedro Park is present at this period. A variety of Late Archaic point types, including Castroville, Frio, Montell, and Pedernales were recovered on the current project. In addition, two of the six radiocarbon dates acquired from the project, CAR 345 and CAR 347, date to this period (see Appendix A).

During this period, large cemeteries are increasingly common in Central and South Texas, including Loma Sandia in South Texas (Taylor and Highley 1995), as well as Olmos Dam (Lukowski 1988) and Hitzfelder Cave (Munoz et al. 2013; see also Givens 1968) in Bexar County. These cemeteries may indicate larger, growing populations and the establishment of territories (Black and McGraw 1985; Story 1985). However, there is no consensus on the patterns of population growth during this time. Prewitt (1981, 1985; see also Weir 1976) suggests increased population relative to the Middle Archaic, while Black (1989) believes populations were constant or even decreased during this sub-period. There is also disagreement as to the continuing use of burned rock middens. Prewitt (1981) suggests that burned rock midden use declined. There appears to be some evidence for this in the eastern portion of the region, though midden use clearly continues throughout the Late Archaic in other areas of Central Texas (see Acuna 2006; Black et al. 1997; Black and McGraw 1985; Goode 1991).

Bison are clearly present during this sub-period in Central Texas and form a component of subsistence (Collins 2004; Dillehay 1974; Mauldin et al. 2012), though some suggest they were again scarce at the close of the Late Archaic (Dillehay 1974). Deer appear to have been widely pursued. Late in this sub-period, subsistence is assumed to reflect the use of a broad spectrum of resources (Black 1989), possibly focused on local plants and animals (e.g., Skelton 1977).

Because of increased interments of human remains during this sub-period, isotopic data on human subsistence are increasingly available for the Late Archaic in Central Texas. Bement (1994) reports data for seven individuals from 41KR241. Hard and Katzenberg (2011) list data for six Late Archaic individuals recovered from the Olmos Dam site (41BX1). Munoz et al. (2011b) present data for four individuals from Hays County that date to the Late Archaic, and Munoz et al. (2013) list isotopic results for 15 individuals from Hitzfelder Cave (41BX26). Fifteen of these 32 interments date prior to 2500 BP, while the remaining 17 date between 2500 and 800 BP. These early burials have an average $\delta^{13}\text{C}$

for collagen of -15.8‰ (range of -14.1‰ to -16.9‰) and an average carbon value in carbonate of -8.9‰ (range of -7‰ to -10.5‰). The 17 later interments have carbon values of -17.6 (range of -15.4‰ to -19.3‰) for collagen and -9.9‰ (range of -8.6‰ to 10.9‰) for carbonate. Comparing the early Late Archaic averages to those from the close of the Middle Archaic suggest a similar overall diet, with a slight increase in C_4/CAM proteins, possibly reflecting increased use of C_4 feeding bison. By the close of the Late Archaic, isotopic data once again reflect an increased dependence on C_3 resources, especially concerning protein intake. This is consistent with increased dependence on deer and other C_3 feeding animals relative to C_4/CAM protein sources, such as bison.

Late Prehistoric

The Late Prehistoric Period (1200-350 BP) is defined primarily by the introduction of the bow and arrow, as well as associated shifts in projectile points (Black 1989; Collins 2004; Hester 2004). The period is traditionally divided into an early sub-period or interval termed Austin (1200-700 BP) and a late interval termed Toyah (700-350 BP). Austin is often seen as an extension of the Late Archaic pattern (see Johnson and Goode 1994), while Toyah is viewed by some as a radically different adaptive pattern. Many see Toyah as reflecting an influx of new groups from the Plains. These groups are assumed to be following bison herds that moved back into the region after an absence during the preceding Austin interval (see Johnson 1994; Shafer 1977). The temporal distinction between the Austin and Toyah intervals was originally proposed by Jelks (1962) based on excavations at the Kyle site (see also Black 1986; Johnson 1994; Kelley 1947; Ricklis 1994a, 1994b).

Like the preceding Late Archaic Period, there are several Late Prehistoric point forms recorded from San Pedro Park, including forms representing both the Austin and Toyah intervals. In addition, two of the six radiocarbon dates acquired on this project, Beta 390003 and 390004, fall in this period (see Appendix A).

Austin (1200-700 BP)

In Central Texas, the Austin interval is defined primarily by the presence of Scallorn and Edwards arrow points (see Collins 2004; Johnson and Goode 1994; Prewitt 1981). With the exception of changes associated with the introduction of the bow and arrow, Austin lithic technology appears to have strong similarities to those in the Late Archaic (Johnson and Goode 1994; Prewitt 1981). Sites with Austin interval material that have provided critical data include Loeve-Fox (Prewitt 1974), Kyle (Jelks 1962), Smith (Suhm 1957), Pat Parker (Greer and Benfer 1975), and Scorpion Cave (Highley et al. 1978).

Cemeteries are present during this period, including interments at Loeve-Fox (Prewitt 1974) and Pat Parker (Greer and Benfer 1975). Indicators of violent death also are present at this time, with several cases of Scallorn points either embedded in bone or found in close association with burials (e.g., Prewitt 1974:46).

Researchers have argued that burned rock middens, presumably involved primarily in plant processing, were used less frequently during this period (e.g., Houk and Lohse 1993), though others suggest that the use of these features peaked during this period (Acuna 2006; Black and Creel 1997; Mauldin et al. 2003). Deer also seem to be a focus during this period, possibly in response to what most researchers see as an absence, or at least a dramatic decline, in bison availability (Collins 2004; Dillehay 1974; but see Mauldin et al. 2012) relative to the Late Archaic.

Direct information on subsistence is available in terms of stable isotopes data from human burials. Huebner conducted isotopic work on 12 burials from the Austin component of the Loeve-Fox site (41WM230) in 1995. Data are on file at the Texas Archaeological Research Laboratory (TARL), and Mauldin et al. (2013) report these 12 analyses. In addition, Cargill (1996) presents data for a single burial, dated to the Austin interval, recovered at 41BX952. These 13 samples have an average $\delta^{13}\text{C}$ carbon signature of -19.2‰, with a range of -17.7‰ to -20.2‰, for collagen, and -13.1‰, with a range of -11.9‰ to -15.4‰ for carbon found in the carbonate. These data clearly show a heavy dependence on C_3 plants (e.g., geophytes, sotol) as well as animals, such as deer, dependent on these resources for food. This represents an intensification of the pattern seen at the end of the Late Archaic. In fact, except for a slight shift seen in the early portion of the Late Archaic towards C_4 /CAM resources, the isotopic record from the end of the Early Archaic through the Austin interval of the Late Prehistoric shows a gradual pattern of increasing C_3 resource consumption.

Toyah (700-350 BP)

The Toyah interval (700-350 BP) is defined, in part, by the first widespread occurrence of pottery (bone tempered brown ware) in the Central Texas region (Black 1989). The period also is characterized by the use of flake/blade lithic technology that represents a departure from the more formal bifacial core reduction that dominated earlier periods. Toyah artifacts include Perdiz and Clifton arrow points, previously mentioned bone tempered ceramics, beveled knives, graters, drills, and end scrapers (see Black 1986; Johnson 1994). Several critical excavations have contributed to the understanding of Toyah. The list includes work at the Rush site (Quigg and Peck 1995), the Rocky Branch site (Treece et al. 1993), the Hinojosa site (Black 1986), the Toyah Bluff Site

(Karbula 2003), the Lehmann Rock shelter (Kelley 1947), the Rainey site (Henderson 2001), the Biesenbach site (Nickels 2000), the Buckhollow site (Johnson 1994), and many others. Kenmotsu and Boyd (2012) present additional background information regarding Toyah, along with summaries of recent research into this period.

Most researchers suggest populations increased relative to earlier periods (Black 1989). In addition, Collins (2004) suggests mobility during this period was extremely high. He infers high mobility given the assumption that populations during this period were dependent on bison. Collins is not alone in that assumption. Because of the frequent co-occurrence of a new set of lithic artifacts (Perdiz points, beveled knives, and end scrapers) with bison remains, researchers have long suggested Toyah material reflected an association with bison, which were thought to have returned to Texas at roughly the same time as Toyah appeared (e.g., Dillehay 1974; Greer 1976; Hester 1975; Huebner 1991; Prewitt 1981). Some suggested that Toyah reflected the movement of people and their technology off the Plains to the north into Central and South Texas (e.g., Johnson 1994; Prewitt 1981; Shafer 1977). Prewitt (1985; see also Black 1986, 1989) suggests, based on an early summary of radiocarbon dates, the technological complex does move from north to south, but others suggest it is the technology, geared to bison exploitation, that diffused among extant populations (Black 1986; Ricklis 1994b).

It is clear that bison were widely used during Toyah, being present on 83% of the 53 Toyah components recently reviewed for Central and South Texas (Mauldin et al., 2012; see also Huebner 1991). Deer, along with other animals, were also common in Toyah sites, as were the remains of local plant resources (Black 1986). Dering (2008) has recently reviewed subsistence data from Central Texas for this period. He concludes that Toyah subsistence was “based on a broad suite of plant and animal resources” (Dering 2008:59). A number of other studies, looking at proxy data for plant processing as well as faunal data, arrive at essentially this same conclusion (see Karbula 2003; Thoms 2008). Toyah adaptations seem to be diverse, rather than simply focused on bison.

Isotopic data from burials that can directly inform on subsistence are somewhat limited for this late period. Cargill (1996), Munoz et al. (2011b), and Mauldin et al. (2013) each report data for single burials that date to Toyah. The bulk of the available data, consisting of isotopic remains from 11 adults and 6 children, comes from work on burials removed from the Coleman site in Bexar County (Mauldin et al. 2012; see also Potter 2005). Focusing on the 14 Central Texas adult burials, these data suggest a radical departure from the previous pattern. The Toyah isotopic data are bimodal, with a group of three burials that show a strong C_4 /CAM diet, and a second group of 11 individuals, all from Coleman, that

show a diet reminiscent of Late Archaic patterns (Mauldin et al. 2013). The C₄/CAM group has an average stable carbon isotopic value of -10‰ (values of -10.4‰, -10.0‰, -9.5‰) and carbon from carbonate that averages -5.8‰ (values of -7.4‰, -5.3‰, -4.7‰). The second group has collagen carbon values averaging -16.4‰ (range = -17.5‰ to -15.8‰) and carbonate stable carbon isotopes averaging -8.7‰ (range = -10.9‰ to -7.6‰).

While both groups show a significant departure from the C₃ dominated pattern seen in the Austin samples, only the three cases in the C₄/CAM dominated group appear to be consistent with a dependence on bison suggested by multiple researchers for this period. Closer reviews of these three cases suggest they, in fact, may not be dependent on C₄ feeding bison. This suggestion comes from the high nitrogen values ($\delta^{15}\text{N}$) exhibited by these three individuals. In human bone, the stable isotopic ratio of nitrogen is primarily tracking protein intake, with the consumption of animal flesh being the primary protein source in most cases (Katzenberg 2008). Nitrogen isotopic values tend to be enriched as a function of trophic level increases, with an increase of roughly 3‰ to 4‰ per trophic level. Bison during Toyah have an average $\delta^{15}\text{N}$ level of 6.2‰ ± 0.9 based on the analysis on 17 samples (Lohse et al. 2012). If bison were the primary source of protein in this second Toyah group, then human $\delta^{15}\text{N}$ values should average roughly 9.7‰, assuming an enrichment of 3.5‰ between bison and human values. The stable nitrogen values for the three C₄/CAM individuals are 11.7‰, 10.7‰, and 13.3‰ (see Mauldin et al. 2013; Munoz et al. 2011b, 2013), all above the expected 9.7‰. While the consumption of other animals with high nitrogen sources, such as catfish, pond and soft-shelled turtles, and waterfowl, could raise the isotopic values of nitrogen in bison consuming humans, these other sources tend to be C₃ in terms of carbon (see Hard and Katzenberg 2011). The consumption of these high nitrogen resources, then, would not be compatible with the strong C₄/CAM signature for carbon in the collagen of these three individuals. The nitrogen and carbon patterns, however, are consistent with a coastal diet, where marine sources tend to have high nitrogen and C₄ based carbon (Hard and Katzenberg 2011; Munoz et al. 2011b). While these isotopic values suggest surprisingly low levels of bison dependence, they do imply that mobility levels increased late in time, with some evidence of coastal individuals dying in the interior.

Historic Background

The Historic Period in Texas, defined by the arrival of Europeans in the region, begins in AD 1528 when Cabeza de Vaca and the survivors of the shipwrecked Narvaez expedition washed up on the Texas Coast on Galveston Island (Favata and Fernandez 1993). While there is significant temporal overlap between the early Historic record and the Toyah interval of the Late Prehistoric (see Kenmotsu and Arnn 2012), here the Historic Period is divided into the Proto-historic (AD 1528-1700), the Colonial/Mission Period (1700-1821), the

Mexican Period (1821-1836), and the Republic of Texas/Early State Period (1836-1900). Information on the post AD 1900 period in Central/South and East Texas can be found in Fehrenbach (2010), Ramsdell (1959), and Campbell (2003).

San Pedro Park itself has not been a prominent site in the previous discussion of Prehistoric Central Texas. In part, this is because, as discussed in Chapter 5, there was surprisingly little professional archaeological work done in the park prior to the mid-1990s. The broad outlines of the prehistoric sequence had been defined by work in other locations by that time. This is not the case for the historic record. San Pedro Springs plays a significant role in the historic accounts of Central and South Texas, in general, and of San Antonio, in particular. While the history of the park is discussed in the following chapter, here major events that happened in the park are noted as appropriate and placed in the larger historical context.

Proto-historic (ca. 1528-1700)

Although European presence in Texas begins with the shipwreck of the Narvaez expedition (Favata and Fernandez 1993; Krieger 2002), forays into Central and South Texas were infrequent until the late seventeenth century (see Wade 2003). The period between Spanish contact in AD 1528 and the establishment of a permanent, sustained European settlement in the region, around AD 1700 (see Chipman and Joseph 2010; Weddle 1968), is the Proto-historic. As noted above, there is a substantial overlap with the end of the prehistoric sequence, often placed at AD 1600, and the beginning of the Proto-historic. While it is the case that prior to the late seventeenth century, interactions between Europeans and Native Americans were sporadic, especially in Central and South Texas (Foster 1995, 1998 2008; Wade 2003), surprisingly little direct archaeological data on Native American and European interaction in Central Texas exists. Recoveries of artifacts clearly dating to this period are rare (see Thoms and Ahr 1995). Much of what is known about the Proto-historic comes from accounts of French and Spanish soldiers and Spanish missionaries.

The shipwreck on the Texas coast in AD 1528 of the Narvaez expedition initiated European contact. Cabeza de Vaca, Alonso Castillo Maldonado, Andres Dorantes de Caranza, and the latter's Black Moor slave Estevanico were the only survivors of the ill-fated expedition (Bandelier 1905). For the next six years, these four lived as slaves among the Texas coastal and inland Native Americans, eventually escaping and returning to Mexico in 1535 (Bandeilier 1905; Favata and Fernandez 1993; Krieger 2002).

One of Spain's earliest ventures into west-central region of what was to become Texas was the Mendoza-Lopez

expedition from El Paso. This occurred between 1683 and 1684 (Wade 2003). The Spanish followed this with increasingly frequent expeditions that ventured farther into Central and South Texas (see Chipman and Joseph 2010; Kenmotsu and Arnn 2012).

An early attempt to establish a permanent settlement in the region was that of René Robert Cavelier, Sieur de La Salle. In 1685, he established the French settlement of Fort St. Louis along Matagorda Bay on the Gulf Coast. Hunger, disease, and escalating hostilities between the French and Native Americans subsequently resulted in the destruction of the colony in 1689 (Foster 1998).

In 1689, in part as a response to rumored French presence, Spain sent General Alfonso de Leon into the region, and in AD 1691, the Teran de los Rios *entrada* was dispatched with the express purpose of securing Spanish East Texas in the face of possible French expansion (Hatcher 1932; see also Cox 2005a; McGraw and Hindes 1987). This *entrada* produced two notable diaries, that of Domingo Teran de los Rios, the first Governor of Coahuila and Texas and leader of the *entrada*, and that of Father Damian Massanet, a participant of the Alonso de Leon *entrada* in 1690. The 1691 *entrada* left Coahuila on May 16. The respective diary entries of Teran de los Rios and Father Massanet for June 13 describe the first official discovery of the San Antonio River valley:

Teran de los Rios:

On the 13th, our royal standard and camp moved forward in the aforesaid easterly direction. We marched five leagues over a fine country with broad plains – the most beautiful in New Spain. We camped on the banks of an arroyo, adorned by a great number of trees, cedars, willows, cypresses, osiers, oaks and many other kinds. This I called San Antonio de Padua, because we had reached it on his day. Here we found certain rancherias in which the Payaya nation lived. We observed their actions, and I discovered that they were docile and affectionate, were naturally friendly, and were decidedly agreeable toward us [Chabot 1937:10].

Massanet:

Wednesday, 13. We left San Basilo after having said mass. We continued northeast, a quarter east, until we passed through some hills covered with oaks and mesquites. The country is very

beautiful...Before reaching the river there are other small hills with large oaks. The river is bordered with many trees, cottonwoods, oaks, cedars, mulberries and many vines. There are a great many fish and upon the highlands a great number of wild chickens...We found at this place the rancheria of the Indians of the Payaya nation. This is a very large nation and the country where they live is very fine. I called the place San Antonio de Padua, because it was his day. In the language of the Indians it is called Yanaguana [Hatcher 1932:54-55; Chabot 1937:10-11].

The Colonial and Mission Period (1700-1821)

The AD 1700 start date for this period is tied to the founding of Mission *San Juan Bautista* near present day Eagle Pass/Piedras Negras along the Rio Grande (Weddle 1968). While there had been earlier attempts to establish missions, such as Mission *San Francisco de los Tejas* near Nacogdoches and *Santismo Nombre de Maria* on the Neches River, neither had been successful (Fox and Cox 2000). *San Juan Bautista* represented the first major Spanish settlement in Central/South Texas (Weddle 1968). However, the founding of this mission, as well as others within Texas was simply a late addition in a long-standing pattern of confrontation between the Spanish and the French, and to a lesser extent, Great Britain, that was manifested at the close of the seventeenth century.

In many of areas of New Spain, as in Texas, the Spanish established missions, presidios, and supporting infrastructure to assimilate and Christianize the indigenous populations, as well as establish claims to territory. Some of the earliest efforts were conducted in the west near El Paso and farther south along the Rio Grande near the modern town of Presidio. This initial wave of missions was a response, in part, to the retreat of the Spanish from the Pueblo regions in the Southwest following the Pueblo Revolt in 1680 (Weber 1992).

A second wave of missions was established in east Texas in the early eighteenth century (see Chipman 1992). The primary threats to Spanish interests in this part of the Texas region were from the French. While the early French settlement near Matagorda Bay had failed, France had maintained a presence in the region, including settlement to the east in what is now Louisiana. As noted above, to counteract the French threat, Spain had attempted to established missions in East Texas as early as 1690 without success. Between 1716 and 1731, the French threat to Spanish interests intensified as France formed an alliance with the other major New World power, Great Britain (Black 1985). In East Texas, likely in response to France's expansion concerns, Spain established several additional missions and a presidio between 1716 and 1717.

As part of that second wave to establish missions and with an eye towards establishing a permanent presence in the region, a series of expeditions were launched by the Spanish in the early eighteenth century. One of these was the Espinosa-Olivares-Aguirre expedition in 1709. As discussed in detail in Chapter 4, Father Isidro Felix de Espinosa of that expedition provided the first known description of the San Pedro Springs in his diary entry for April 13, 1709 (Tous 1930a:5). The Spanish again passed through the San Antonio area in 1716 in an expedition under the direction of Domingo Ramon (Tous 1930b). The Alarcon Expedition of 1718-1719 (Hoffman 1938) established a permanent presence in the region. As a direct result of the Alarcon Expedition, the *Villa de Bexar* and Mission Valero were founded in 1718, near San Pedro Springs (Cox 1997, 2005a, 2005b), and several other missions were soon established in the region (Carlson 1994; Habig 1968). Shortly after the founding of Mission Valero, the construction of an *acequia* to water crops was initiated from San Pedro Springs (Cox 2005a; Porter 2011).

In June of 1719, the French again made entrance into Spanish East Texas. France had previously declared war on Spain in January of 1719 as a result of Spain's occupation of Sardinia and invasion of Sicily. This precipitated the War of the Quadruple Alliance (Simmer 2013), and the belligerents interacted both continentally in Europe as well as in far-flung colonial possessions. In May of 1719, the French attacked and seized Spanish Pensacola. Under the command of Lieutenant Blondel, French forces from Nachitoches crossed the Sabine River and marched on Mission *San Miguel de los Adaes*. What precisely happened is still a matter of some conjecture. Buckley (1911:10-11) states:

The facts of the case, as gathered from this letter [From Fathers Margil and Espinosa reporting to the Viceroy July 2, 1719] and other sources, seem to be that about the middle of June, 1719, a month after the capture of Pensacola, the French commandant at Nachitoches went in person to the Mission *San Miguel de los Adaes* and captured its occupants. This was not in itself a prodigious feat, for these at the time numbered two – a lay brother and a ragged soldier...Seemingly satisfied with his work, Blondel started home, taking in his custody the lay brother, the soldier, the sacred vessels, ornaments, and other utensils from the mission church. He did not even spare the chickens (who) Not submitting willingly to captivity by the French they made desperate efforts to escape, and the wild flapping of their wings so frightened the horses the Blondel, the commandant, was thrown. In the consequent confusion, and with the aid of some friendly French soldiers, the lay brother made his escape. So the Spanish chronicler continues “Monsieur

Commandant returned to his presidio, glorious in the triumph over one worthless soldier and the captured chickens, whose lives were presumably not spared...since they had so treacherously threatened their captor” [Buckley 1911:10-11].

When the escaped lay brother reached the other Spanish missionaries he informed them of the events at Adaes and that the French forces were planning on attacking all Spanish possessions in East Texas.

The permanent Spanish presence, established in Central Texas at *San Antonio de Bexar* in 1718, solidified over the next few years as the Spanish responded to the French “incursion”. The immediate result was the precipitous abandonment of all the Spanish missions in East Texas and a retreat to the nascent villa, presidio, and mission of San Antonio de Valero. However, an *entrada* under the command of Governor José de Azlor y Virto de Vera, Marques de San Miguel de Aguayo, entered Texas in force in April 1721 to reclaim, reoccupy, and expand the previously token Spanish presence. The chronicler of that *entrada*, Father Juan Antonio de la Pena, in the prolog to his diary presents the Spanish cause:

De la Pena:

So that peoples of all times may know what prompted this entrada, it may be well to state at the outset that it was occasioned by the fact that twenty-one years ago the French, instigated by their traders in Paris, had established a colony at Mobile, a port on the Gulf of Mexico, twelve leagues from our presidio of Santa Maria de Galve, commonly known as Pensacola. During the past twenty-one years they have extended their colonization to the Nachitoches, or Red River, that is, as far as Los Adaes, in the Province of Texas, a distance of some 300 leagues, and have also carried on their work of colonization up the Empalizada, or Missouri River, for a distance of some 400.

Taking advantage of the truce existing between the two powers, French troops surprised the garrison at Pensacola, and at the same time, June 19 of last year, 1719, invaded the Province of Texas. The Padres and Spaniards, because of superior forces [of the enemy] were obliged to withdraw from the six missions which had been established, and retired to the presidio of San Antonio de Bejar. This presidio is situated on the boundary of the Province of Coahuila, and is 240 leagues from Los Adaes, on the [northeast] boundary of Texas. (Forrestal 1935:3-4)

The Aguayo *entrada*, as a result of its large scope, need for men and materials, as well as difficult weather, did not cross the Rio Grande until March 23, 1721. The *entrada* contained 84 veterans, 500 men, nearly 5,000 horses, 1,100 mules, and a year's worth of provisions and supplies (Forrestal 1935:5-7). Accompanying the expedition was a religious contingent led by the Father Espinosa who had previously participated in the *entradas* of 1709 and 1716. However, Father Espinosa left the chronicling of the *entrada* to de la Pena.

The Aguayo *entrada* reached San Antonio on Friday, May 4, 1721. At San Antonio, the Marques visited both Mission *San Antonio de Valero* and the new Mission *San Jose y San Miguel de Aguayo*, which he had authorized the establishment of the year prior in 1720. After resting the horses and adding to his supply of men, material, and missionaries, Aguayo commenced his march to East Texas on May 13. The Marques de Aguayo spent the remainder of the year 1721 reestablishing the East Texas missions and presidios (Forrestal 1935). His efforts were made the easier by the simple fact that between the time of the French predations of 1719 and the arrival of the Marques in 1721, the Spanish and French had agreed to an understanding that resulted in French abandonment of Spanish lands (Hackett 2010).

The next major series of events that influenced the Colonial/Mission Period in the region were associated with the Seven Years War (1754-1763). It pitted Great Britain and their allies against France, Spain, and their allies (Baugh 2011). While there were extensive battles in eastern North America, there appears to have been little fighting in the Spanish dominated areas of Texas. The British, however, replaced the French as the major external threat to Spanish dominance in the region. As a result, Spain shifted emphasis, resulting in further deterioration of missions in the region (Carlson 1994).

By the close of the eighteenth century, missions in San Antonio, as well as elsewhere in the region, were on the decline. Falling population totals and several epidemics, including small pox and measles, hastened this decline (Ewers 1973). In 1794, a decree was issued that called for the secularization of San Antonio missions, and several, including *San Antonio de Valero*, were essentially abandoned (Cox 1997, 2005b). Missions in the area were secularized by 1824 (Carlson 1994; Cox 1997).

At roughly this same time, colonial rule ended. Tensions at the close of the eighteenth century between Spain and its colonies in Texas and Mexico increased, and in 1810, several groups rebelled against Spanish control. The rebels were eventually successful, and in 1821, Mexico became independent, essentially ending colonial rule (Henderson 2009).

The Mexican Period (1821-1835)

The successful ouster of Spain in 1821 was followed by a new constitution in 1824. The 1824 Constitution merged Texas with the state of Coahuila and moved the state capital from San Antonio de Bexar to Saltillo. The Constitution also enacted a series of laws that enabled heads of households to claim land in Mexico. This resulted in an influx of settlers from the United States into Texas, with many concentrating on East Texas farmlands (Cox 1997). These laws were subsequently changed. By 1830, immigration from the United States into Texas was prohibited, and this was enforced by the establishment of several presidios, associated troops, and increasingly centralized control by Mexico City (Cox 1997; Fehrenbach 2000; see also Barker 1928; Campbell 2003; Weber 1982).

Demands for greater autonomy and tighter control from Mexico City eventually resulted in the battle of Fort Velasco. Rebel forces captured the fort at the mouth of the Brazos River in 1832 and called for a return to the freedoms proposed in the 1824 Constitution. A peaceful solution was eventually negotiated, though tensions continued to rise (Cox 1997).

Santa Anna took control of the Central Government in 1834. He soon dispatched forces under the command of General Cos to deal with unrest in Coahuila and Texas, and he officially revoked the Constitution of 1824. General Cos eventually arrived in San Antonio, and in October of 1835, a rebel army under the command of Stephen F. Austin moved to displace the Mexican forces. In December, Cos surrendered and eventually withdrew his forces. In February of 1836, Santa Anna and a Mexican army arrived on the outskirts of San Antonio to retake the city. Rebel forces retreated to what remained of Mission *San Antonio de Valero*. After a short siege, the Alamo fell in early March. The following April, Santa Anna's forces were defeated at the battle of San Jacinto. Santa Anna was captured, and Mexican forces withdrew (Cox 1997; Davis 2004).

The Republic of Texas and Early Texas State (1836-1900)

The Republic of Texas was established in March of 1836 with Sam Houston as the first president. Mexico did not recognize the Republic as an independent entity, and there were continuing disputes. Many of these involved the establishment of the southern boundary of the Republic (Fehrenbach 1983). A state of war continued between the two entities, though no formal hostilities occurred until 1842. In March of that year, a Mexican force of 700 soldiers briefly occupied San Antonio, as the Texas forces offered no resistance. In September of that year, forces loyal to Mexico again captured the city, and again withdrew. An armistice was reached in June of 1843 between Mexico and Texas that reduced tensions (Cox 1997).

Texans were ill prepared for independence in 1836. While recognition by the United States of the Republic was relatively quick, annexation to the United States, which shared close ties to many influential Texans, was slow. Significant foreign debt and support of slavery within the Republic in the context of increasing disagreement on slavery within the United States delayed annexation. Nevertheless, late in 1845, the United States Congress and the Texas Republic agreed to annexation terms. Texas was admitted to the as the twenty-eighth state on December 29, 1845 (Neu 2013; TSLAC 2014).

Mexico broke diplomatic relations with the United States on learning that the United States had sent an invitation to the Republic of Texas to become a state. By early 1846, disputes on the location of the southern border that had initially been between Texas and Mexico were now between Mexico and the United States. Various skirmishes occurred in between Mexican and United States troops, and on May 13, 1846, a declaration of war was issued by the United States. The war was fought on Mexican soil, and in 1847, General Winfield Scott landed an army at Veracruz and eventually occupied Mexico City ending the conflict. The Treaty of Guadalupe-Hidalgo ended the war in February of 1848. The treaty established the Rio Grande as the southern boundary between the United States and Mexico, and Mexico ceded territorial claims to what is now most of Arizona, California, New Mexico, Nevada, Colorado, Utah, and Texas to the United States in exchange for \$15 million (Campbell 2003; Wallace 1965).

Following the war with Mexico, Texas experienced rapid population growth. These influxes occurred both from the southern United States and from Europe, with the later dominated by German and Czech immigrants. Texas population increased from roughly 142,000 in 1847 to just over 600,000 by 1860 (Campbell 2003). One of the draws to this significant growth was the availability of farmland. Cotton, often supported by slave labor, was dominant in East Texas. In 1846, more than 30,000 black slaves were present in the state (Campbell 1989; Cox 1997), a number that increased to over 180,000 by 1860 (Campbell 1989, 2003). Not surprisingly, with the outbreak of the Civil War, Texas sided with the Confederacy. Texas seceded from the United States in February of 1861 and joined the Confederate States of America in March. There were few major battles within Texas, though Texans fought on both sides of the conflict (Campbell 2003).

Following the defeat of the Confederacy, Texas was subsequently readmitted to the United States in 1870. Population growth continued, and major industries initially developed around farming and cattle ranching (Campbell 2003; Sonnichsen 1950). Railroads expanded into the state (Reed 1941), arriving in San Antonio in February of 1877 (Cox 1997). Civic improvements, including efforts at flood control and sanitation (Cox 1997, 2005a), set the stage for increasing commercial developments throughout the remainder of the nineteenth century.

Chapter 4: A History of San Pedro Park

Clinton McKenzie, Raymond Mauldin, Stephen Smith, Antonia Figueroa, and Kristi Nichols

As mentioned in the previous chapter, San Pedro Springs figures prominently in the historical accounts related to the early Spanish *entradas* into the region and the springs were the original location determined in 1718 for the founding of what would subsequently become San Antonio. The initial portion of this chapter reviews in detail the founding and early development of the park. For the purposes of this initial summary of the early history of San Pedro Springs, particular attention is paid to the *entradas* of 1709, 1716, 1718, and 1722. This review focused on primary documents, principally translations of original Spanish sources Bolton (1905), Hoffmann (1935, 1938) Casteñeda (1936), Chabot (1932, 1941), Bandelier (1905), Tous (1930a), Foik (1933), and Forrestal (1935). Additional information on park history is derived from Cunningham (2006), McDonald (2013), Cox (1999, 2005a, 2005b), Crook (1967), Foster (1995), Kendall (2013), Nichols (2014), and Uecker (1991), as well as planning documents (RVBK 1994; Beaty Palmer 2013) and archival historic maps on file at the Center for Archaeological Research and the archives of the City of San Antonio.

Founding and Early Developments (1709-1851)

Members of the 1709 Espinosa-Olivares-Aguirre *entrada* (Tous 1930a) first described San Pedro Springs. The Espinosa-Olivares-Aguirre *entrada* consisted of the two Friars Isidro Felix de Espinosa and Antonio de San Buenaventura y Olivares, as well as Captain Pedro de Aguirre and a small company of soldiers. The purpose of the *entrada* was to explore Central Texas, establish contact with the Tejas, determine their attitude towards the Spanish, and dissuade them from trading with the French who were making encroachments from Louisiana (Bolton 1905; Chabot 1932; Chipman 1992). Fray Espinosa acted as the chronicler of the *entrada* that set out in early April 1709 from San Juan Bautista on the Rio Grande. Espinosa's diary (Tous 1930a) describes the discovery and naming of the San Pedro and San Antonio Springs, as well as San Pedro Creek and the San Antonio River, on April 13, 1709:

13 - We continued our course towards the east through some ravines...until we arrived at the arroyo of Leon [presumably modern day Leon Creek] which had running water, and we crossed it about a gunshot from where General Gregorio Salinas crossed it some years before. We crossed a large plain... and after going through a mesquite flat and some holm-oak groves we came to an irrigation ditch, bordered by many trees and with water enough to supply a small town. It was

full of taps or sluices of water, the earth being terraced. We named it San Pedro Spring... and at a short distance we came to a luxuriant growth of trees, high walnuts, poplars, elms and mulberries watered by a copious spring which rises near a populous rancheria of Indians...The river, which is formed by this spring, could supply not only a village but a city...This river not having been named by the Spaniards, we called the river of San Antonio de Padua [Tous 1930a:5].

Note that Espinosa refers to the area of the San Pedro Springs as containing an irrigation ditch, sluices, and terraced areas at the time of discovery. No other documentation makes this claim. There are several possible interpretations of Espinosa's description of irrigation features at San Pedro Springs. If the translation is accurate, the features could have been constructed by a Spanish contingent associated with the 1691 *entrada* (see Chabot 1937:8-9) or by Native Americans present in the area. There is, however, no evidence for an earlier, semi-permanent Spanish occupation consistent with the development of these features, and there is no historical or archaeological evidence that Native Americans in Central Texas practiced irrigation. Several subsequent Spanish observers present just nine years later in 1718 (see Hoffman 1935, 1938) make no mention of the irrigation features or terraces described by Espinosa. The most likely interpretation is that the Espinosa account either represents a problem with the translation (see Cox 1999:6) or that he was simply wrong (Doolittle 2000:353).

The next recorded venture to the San Pedro/San Antonio area occurred in May of 1716 (Foik 1933; Tous 1930a, 1930b; see also Cunningham 2006:54). An *entrada* under the command of Don Domingo Ramon passed through the area on its way to East Texas to reestablish a Spanish presence as a bulwark against French expansion. This *entrada* produced two diaries, one by the commander Don Domingo Ramon and the other by the same Father Espinosa who was diarist for the 1709 *entrada*. The *entrada* left San Juan Bautista on April 25, 1716, and arrived in the San Antonio River Valley on May 14. Both diarists recorded the event:

Ramon:

14 On this day I marched northeast seven leagues through mesquite brush with plenty of pasturage. Crossing two dry creeks we reached a water spring on level land, which we named San Pedro. There

was sufficient water here for a city of one-quarter league, and the scenery along the San Antonio River is very beautiful, for there are pecan trees, grapevines, willows, elms and other timbers. We crossed said stream, the water which is not very deep reached our stirrups. We went up the river looking for a camping place and we found a very fine location. There were beautiful shade trees and good pasturage, as we explored the head of the river. Here we found, in the estimate of twelve ultra-marines [Spaniards], hemp nine feet high and flax two feet high. Fish was caught in abundance for everyone, and nets were used in the river with facility [Foik 1933:12].

Espinosa:

May 14 – Thursday. We set out for the aforesaid river [the San Antonio] in the direction of east-northeast through hills and dales all covered with very green gramagrass. Some flint stones were found all along the way from the Arroyo de Leon [presumably Leon Creek] which is three leagues distant from the river. In this stream there are pools of water. From thence northeast we entered the plain at the San Antonio River. At the end of the plain there is a small forest of sparse mesquites, and some oaks. To it succeeds the water of the San Pedro; sufficient for a mission. Along the bank of the latter, which has a thicket of all kinds of wood, and by an open path we arrived at the River San Antonio. This river is very desirable [for settlement] and favorable for its pleasantness, location, abundance of water, and multitude of fish. It is surrounded by very tall nopals, poplars, elms, grapevines, black mulberry trees, laurels, strawberry vines and genuine fan palms. There is a great deal of flax and hemp, an abundance of maiden-hair fern and many medicinal herbs. Merely in that part of the density of its grove which we penetrated, seven streams of water meet. Those, together with others concealed by the brushwood, form at a little distance its copious waters, which are clear, crystal and sweet. In these are found catfish, sea fish, pilonte, catan [gar], and alligators. Undoubtedly there are also various other kinds of fish that are most savory. This place mellowed the dismal remembrance of the preceding one. Its luxuriance is enticing for the founding of missions and villages, for both its plains and its water encourage settlement. We travelled this day seven leagues [Tous 1930b:9-10].

Both Ramon and Espinosa praised the location as ideal for the founding of a city, village, and missions. In no small measure Espinosa's praise for the area in 1709 and 1716, together with Father Massenet's continued vocal support contributed to its subsequent site selection two years later in 1718.

In 1718 Martin de Alarcon, Governor of Coahuila and Texas, led an *entrada* into Texas for the purpose of re-supplying the East Texas missions (Chipman 1992:116-117). In addition, Alarcon was charged with founding a way station between the Rio Grande and the East Texas missions. To that end, Alarcon selected the San Pedro Creek area as the location for the new settlement that would include a mission for conversion of the Indians, a presidio for defense and to act as a depot for re-supply, and a villa on the site. Unlike previous *entradas*, Alarcon took with him several families to aid in establishing the new town. Appendix B lists the names of both soldiers and civilians who accompanied the Alarcon *entrada*, including those present at the founding on May 1, 1718, and those listed as assigned to the presidial forces in June of 1718 upon return from East Texas (Chabot 1937:94; Garcia 2014; Hoffman 1935:43). The *entrada* also contained a party of Franciscans under the leadership of Father Antonio de San Buenaventura Olivares, an often irascible and difficult missionary. Olivares made numerous complaints against Alarcon, and when the expedition departed from the Rio Grande, the parties traveled separately to San Antonio due to the animosity between the two leaders (Chipman 1992:117; Hoffman 1935:24).

Like the *entradas* that preceded it, the Alarcon expedition was memorialized by two diaries, that of the Franciscan Fathers Francisco Celiz and Pedro Perez de Mezquia. The Alarcon party reached the San Antonio River on April 25, 1718. The event is recorded by both Celiz and Mezquia.

Celiz:

On the 25th, the camp left this place for the San Antonio River, which is about six leagues distant. The road is mountainous in the canyon which they call De Leon, which is about three leagues from the above-named place. The remainder of the road is level. In this place of San Antonio there is a spring of water which is about three-fourths of a league from the principal river. In this locality, in the very spot on which the villa of Bejar was founded, it is easy to secure water, but nowhere else. At the upper end of said spring is a thick wood of different trees, such as elms, poplars, hackberries, oaks, and many mulberries and brambleberries, and the rest of the wood is covered with grapevines from the ground up. On

this day two squads left the camp to examine the river above and below. In the upper part, which is where the governor went, nothing of use could be found, because those who understand the matter say that a place to draw water may be had only with much difficulty and expense; the captain who went to the lower end, to where the first creek joins the river, says that there is no place whatsoever to draw water, because the river flows in a very deep channel. They did not go any farther because it had begun to rain [Hoffman 1935:48-49].

Mezquia:

On the 25th we arrived at the first spring of San Antonio [i.e. the San Pedro] which is about six leagues distant. The road is rough until arriving at the creek which they call De Leon, which is about three leagues from the Medina. Near it is another with running water, which they say runs abundantly further downstream. The rest of the road is very level. This place in which we find ourselves is pretty because of the trees that it has its spring. The water is sweet and very fine. Where the two springs meet the stream is two varas wide and more than a vara and a half deep. It is swift, very easy to extract, and leaves the stream to irrigate good and sufficient lands. The trees which the wood contains consists of pecans, mulberries, elms, and poplars, and there are also many grapevines, one of which is larger than the one on the Frio River [Hoffman 1938:317].

On the arrival of Olivares, Alarcon established the Mission *San Antonio de Valero* on May 1, 1718, and four days later, on May 5, he founded the *Villa* and the *Presidio de Bexar* that were located a short distance away near the San Pedro Springs. Both diarists mention the events:

Celiz:

On the 5th of May, the governor, in the name of his Majesty, took possession of the place called San Antonio, establishing in it, and fixing the royal standard with the requisite solemnity, the father chaplain having previously celebrated mass, and it was given the name of villa de Bejar. This site is henceforth destined for civil settlement and the soldiers who are to guard it, as well as for the mission of San Antonio de Valero, established by said governor about three-fourths of a league down the creek [Hoffman 1935:49].

Mezquia:

The governor took possession of all this land on the 5th of May, fixing the royal standard on it as a symbol of possession, after the holy sacrifice of the mass had first been celebrated. The mission of the reverend father, Fray Antonio de San Buenaventura y Olivares, is near the first spring, half a league from a high ground and adjoining a small thicket of live oaks, where at present he is building a hut [Hoffman 1938:318].

Both sets of diary entries note a first spring, which is the San Pedro. Of particular note is Father Celiz's statement that "In this place of San Antonio there is a spring of water which is about three-fourths of a league from the principal river. In this locality, in the very spot on which the villa of Bejar was founded it is easy to secure water, but nowhere else" (Hoffman 1935:49). It is clear from Celiz's account that the *Presidio* and *Villa de Bexar* were located at San Pedro Springs, about 10,000 feet from the principal river, the San Antonio. Further corroboration is Celiz's remark that it is easy to secure water from this location and nowhere else. Celiz (1719) also stated that Alarcon, on his return from East Texas on January 12:

...gave orders to begin with all assiduity the construction of the canals for both the villa and the said mission of San Antonio de Valero. This work was continued the remainder of said month, in which time they were built in good state and shape, so that this year a fine crop of corns, beans, and other grains which the governor ordered brought in from the outside is expected [Hoffman 1935:86].

From these two statements, it is certain that the villa, presidio, and *acequia* were all located adjacent to San Pedro Springs and Creek. They also establish the date for the excavation of the *Acequia de San Pedro* in January of 1719.

Further information concerning the location of the original settlement is found in the journal entry of Father Mezquia dated June 17, 1718:

On the 17th we reached camp [on the San Antonio] at about three in the afternoon. Here we found everything in good shape. From this day to the 15th of June, the camp was moved to the other side of the creek, between the river and the creek, where several huts and some corrals for livestock have been built and some gardens have

been planted. About a 12th of a bushel of corn has been planted [Hoffmann 1938:323].

Also of note, is the first location of Mission *San Antonio de Valero*, which was not located with the *Villa de Bexar* or *Presidio de Bexar*. Celiz's diary records that the mission was located "three-fourths of a league down the creek [San Pedro]" (Hoffman 1935:49). Mezquia's diary records the mission as being "half a league from a high ground and adjoining a thicket of live oaks" (Hoffman 1938:318).

A year after their founding, the archival documents indicate that structures for dwelling and defense had been constructed. In addition, an *acequia* had been excavated and put into operation, and the crops had been planted. However, the *Aguayo entrada* returned to San Antonio following their foray into east Texas in January 23, 1722, to await new provisions (de la Pena 1722). This would initiate several changes.

De la Pena:

Informed through several letters that the horses he had requested would not arrive for more than a month and a half, and that the presidio of San Antonio was defenseless, and, as had been observed but a short time previously, exposed to fire because of the fact that the soldiers were living in thatched huts, his Lordship planned to build of adobe brick a fortress which would not be in danger of burning. After ordering the cutting of the necessary lumber for the church, stores and quarters, His Lordship selected a better site than that on which the presidio used to be located. [This new site] was between the San Pedro and San Antonio rivers. It was first necessary to clear the land by cutting down many trees. A great number of people were then put to work making adobe [bricks]. His Lordship then outlined the fortress as a square with four bulwarks so that if ever the soldiers chanced to be absent and an invasion took place a few men, stationed on opposite corners, could hold the fort, defending from each bastion two curtains, each of which, from bastion to bastion was to be 75 varas long. He proposed also that with irrigation facilities from the water-ditch, which at his own expense he had made from the San Pedro River, a large crop of corn be raised with which to supply the presidio and also the friendly Indians that each day come to see the Spaniards. The water-ditch will be able to

irrigate the two leagues of very fertile land which make up the small valley formed by the San Pedro. The latter enters San Antonio a short distance below the presidio, forming between the two, a sort of island. The presidio, which is built on this island, will be about thirty varas from the San Pedro and about 200 from the San Antonio [Forrestal 1935:60-61].

The second location of the presidio and villa were subsequently to form the nucleus of what was to become San Antonio. Aguayo's impact on Spanish Texas and San Antonio were profound (Chipman 1992:126). His efforts ensured the viability and vitality of the settlements established at San Pedro by Alarcon in 1718 and provided a safe, fertile location for the missions removed from East Texas in 1731.

In that same year, settlers from the Canary Islands arrived in *Villa de Bexar*, and work continued on the irrigation system anchored to the springs (Cox 1999, 2005a, 2005b). Eventually, this system would provide water to most of the growing settlement (Cox 2005a; Porter 2011). In part because of the demand for irrigation, San Pedro Park was within a public land decree issued by the King of Spain in 1729 (Corner 1890). It appears that little was done regarding irrigation and water distribution until the 1770s, when, after a variety of primarily citizen led efforts, the *acequia* was eventually completed in 1778 (Cox 1999; 2005a). Reference to precipitation patterns shown previously (see Figure 2-2) will demonstrate that demand for action may be related, in part, to rainfall patterns. The period from 1718 through 1770 were dominated by high rainfall years, with three short droughts. The period from 1770 through the early 1790s were dominated by below average rainfall (see Figure 2-2).

Figure 4-1, a map of the area prepared by San Antonio City Engineer Gustav Freisleben, shows San Pedro Springs and the Creek in 1860, as well as the location of the San Pedro *Acequia* exiting from the park to the south. Figure 4-2 provides a map compiled from various sources during the development for the City of San Antonio of the 1992-1994 Master Plan for the park (Beaty Palmer 2013; RVBK 1994). The map shows the springs, associated lake area, and the San Pedro *Acequia* and Creek exiting the park to the south. Also shown are the Camino Real/Old San Antonio Road, coming up from the south and intersecting with the road to Fredericksburg to the northwest. It is likely that the Camino Real approximates the routes followed by the early *entradas* coming up from the Rio Grande and heading towards east Texas (McGraw et al. 1991).

Water was not the only resource that was available and in demand at San Pedro Park. The other major resource appears

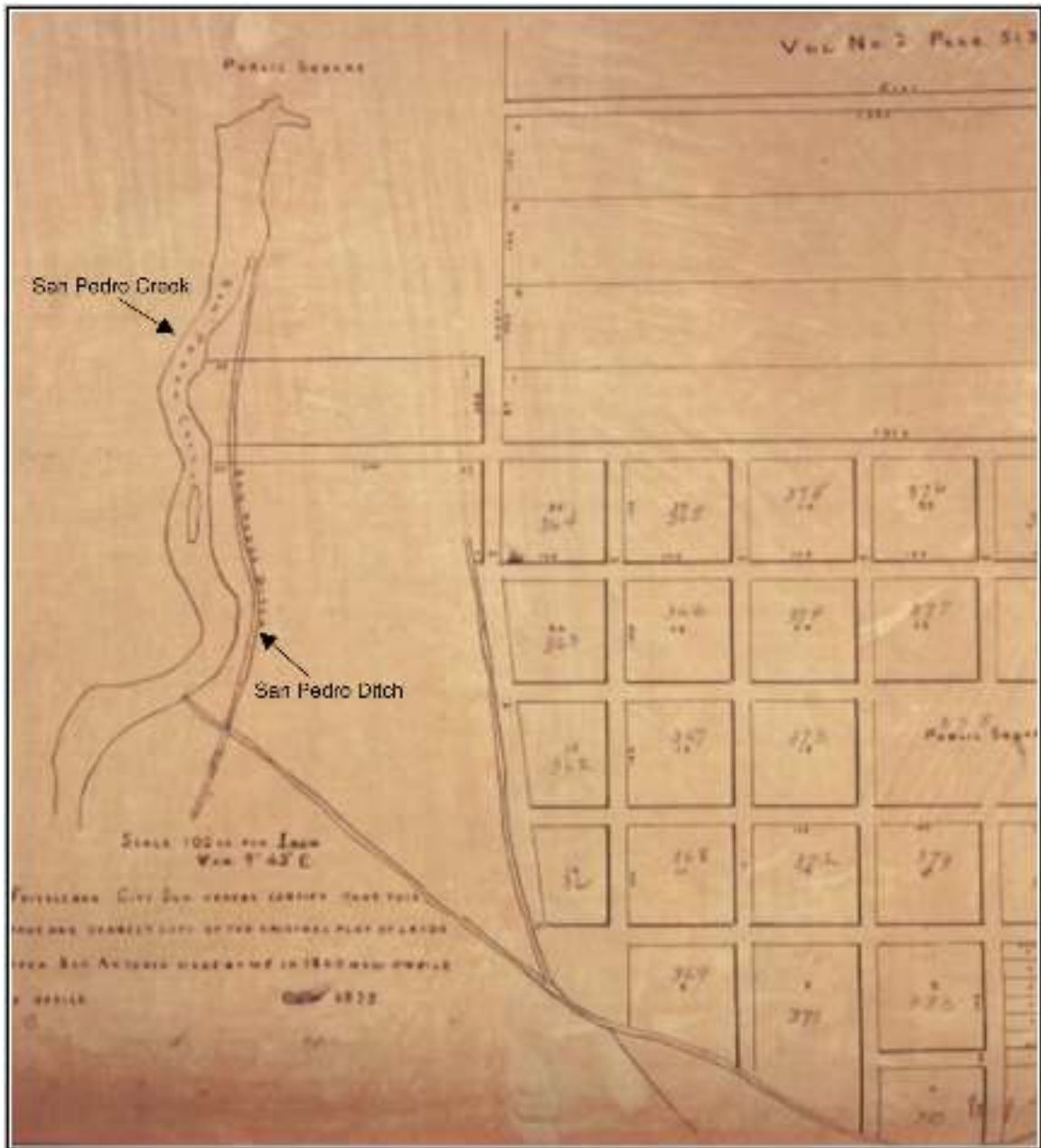

Figure 4-1. Map of San Pedro Springs, San Pedro Creek, and the San Pedro Ditch in 1860. Drawn by Friesleben, City Engineer (Plat Book 2:40, COSA 2014).

to have been limestone for building materials. Cox (1999:8) notes that

The northeast corner of what now constitutes San Pedro Park served as the closest hard-limestone quarry to the city until well into the nineteenth century. Although the exact date of the beginning of the quarry has not been determined, its proximity to the city may indicate Spanish colonial use. The limestone

was removed from the high margin of exposed stone that extended into what is now known as Tobin Hill.

Figure 4-3, a City of San Antonio survey map completed in 1870 by Hartnett, shows what appears to be a series of upland ridges, dissected by two narrower valley/ravines, in this section of the park. This upland area in Figure 4-2 corresponds with the mapped distribution of the Eckrant cobbly clay (TaC) soils (see Figure 2-7), which are associated

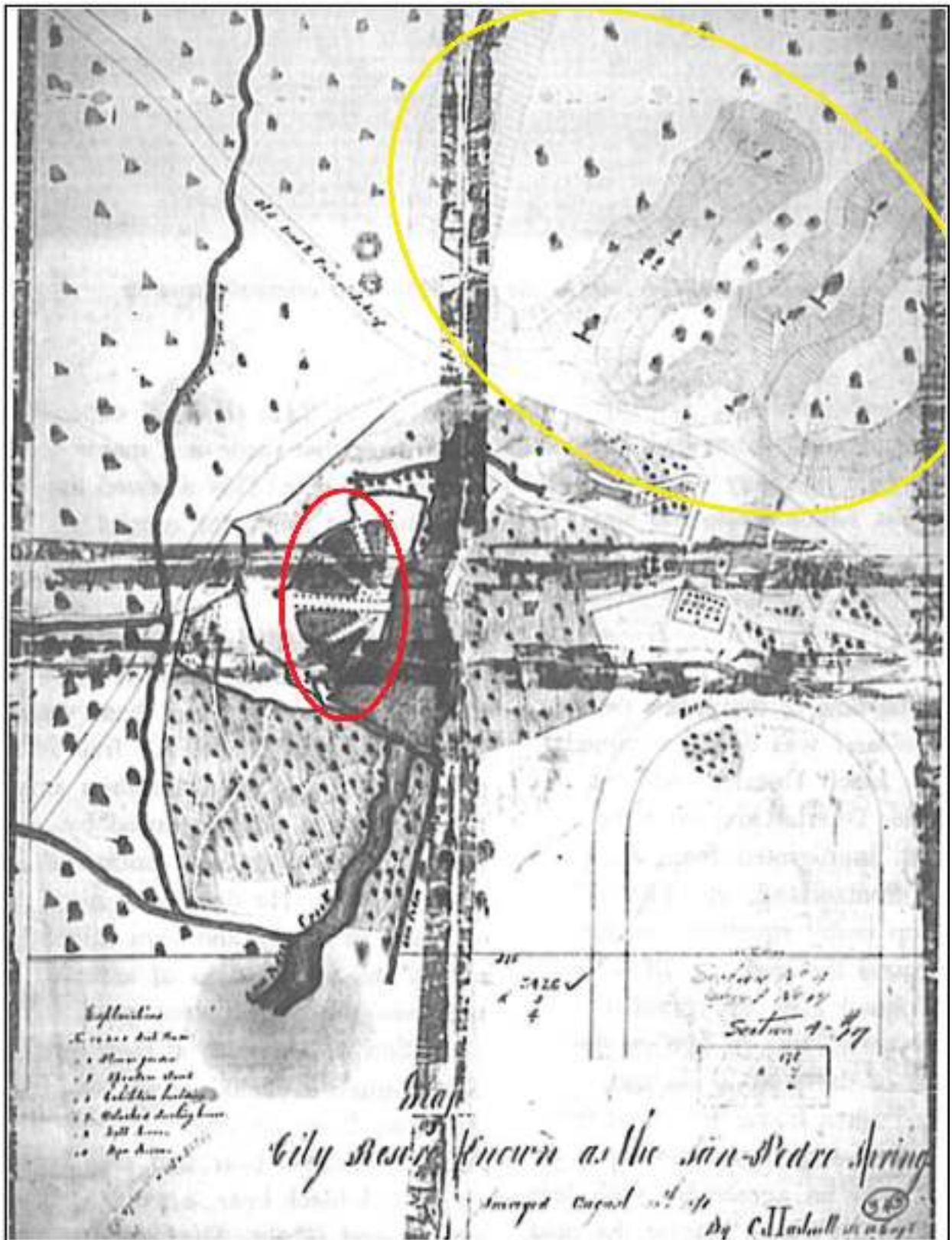

Figure 4-3. An 1870 City Map of San Pedro Park by C. Hartmill (from Cox 1999:9). Note hills depicted in the northeast corner of the park. Yellow circle highlights quarry area. Red circle highlights fishponds. Note acequia and San Pedro Creek as well as the apparent dam along the southern edge of the lake/springs.

Acequia. Construction on the Alazán ditch began in 1874, and the ditch was operational by 1875. It was constructed both to alleviate flooding and to provide irrigation (Cox 1999, 2005a). It appears to have been closed in 1895 (RVBK 1994). Figure 4-4 shows San Pedro Park with major features identified prior to 1890. The Alazán ditch came into the park on the northwestern side, cut above the headwaters of the springs and over to the southeastern side, where it exited the park to the south. Note also the 1870s “rainwater passage” shown in Figure 4-4. This is the one of several such drainage channels along this portion of the park constructed or altered over the next 50 years.

In 1891 at the end of a series of leases, the City initiated a number of improvements to San Pedro Park, which had significantly deteriorated in the previous decades. Over the next 10 years, a variety of changes were implemented. These included the establishment of a baseball field in the far southeastern section of the park and the installation of electric lighting. The lake area was lined with masonry, and Duerler’s fan-shaped pools (Figures 4-3 and 4-4) were filled with sediment (Cox 1999:10). Much of this work was conducted in 1899. The E.G. Trueheart Map, dated June 23, 1899, provides a detailed, accurate representation of San Pedro Park that appears to date prior to the start of the 1899 construction (see Houk 1999:14). The Trueheart Map was likely the baseline for that construction, and the construction was substantial. The *San Antonio Light* (*SAL*) of July 4, 1899, reported that though the work was not complete at that time the:

scene is wonderful. Where there was formerly a sluggish, muddy lake spanned by a rickety, dangerous bridge and fed by a spring that barely bubbled, is now to be seen a clear, blue lake, fed by a gushing spring as beautiful and clear as the Biblical crystal and spanned by two pretty little bridges [*SAL*, 4 July 1899].

In addition, and critical for the subsequent investigation, the 1899 report states that:

The black dirt that always got so muddy has been covered with white dirt and rolled, the mesquite brush and other underbrush has been cut and grubbed, the lake has been walled around with rock, the mudholes known formerly as ponds [...] have been filled [*SAL*, 4 July 1899].

Figure 4-5 presents the Trueheart Map of 1899. As noted above, this appears to be a pre-construction view of the park. The modern park features have been overlain on this historic map to highlight several aspects. These include the overlook

where the tennis courts now stand and the area to the south that shows the San Pedro *Acequia*. While this map will be discussed at several points in this and subsequent chapters, several features should be highlighted here. First, the map is an instrument based survey map with several stations and is highly detailed. Consideration of the map will show that there are several enclosures and small buildings not seen on other maps. In addition, the “Old Fort” is not present on this 1899 map. Given the level of detail, it is unlikely that this building was not recorded. This suggests that this structure was not present in 1899.

The 1899 renovations reported in the *San Antonio Light* included the destruction of the “rotten building known as the lower pavilion” and “blasting out the hillside...” (*SAL*, 4 July 4 1899). By the end of August, 1899, the *San Antonio Light* reported that the “portion of the park southwest of the lack that was once a wilderness of weeds, has now been cleaned” and “artistic walks have been constructed” (*SAL*, 27 August 1899). The *San Antonio Light* further reports that “sifting from the Parker Washington crushing plant on the hill above the springs have been used for these walks” (*SAL*, 27 August 1899). The scale of earth movement associated with these renovations was substantial. The *San Antonio Daily Express* (*SADE*, 12 September 1899) printed a commissioner’s report following the work that estimates that 11,981 m³ of rock, gravel, and dirt were placed in the park. Most of this figure, or roughly 8610 m³, was fill dirt.

Figure 4-6 provides an additional visual summary of San Pedro Park and its features at the turn of the century. Comparisons with the Trueheart Map show several interesting differences, including the location and size of the stable, the shape and size of the zoo, the lack of a block house structure on the 1899 map, and the addition of several fenced enclosures. Regardless of these, the 1899 work clearly transformed the park.

San Pedro Park in the Twentieth Century

Following the renovation at the close of the nineteenth century, the park was once again a central attraction. Figure 4-7 shows two views of San Pedro using photo-based postcards from the early twentieth century. The *San Antonio Light*’s description of a “... clear, blue lake, fed by a gushing spring as beautiful and clear as the Biblical crystal...” seems appropriate (*SAL*, 4 July 4 1899).

The transformations initiated at the close of the nineteenth century within the park continued into the initial decades of the twentieth century. Many of these are highlighted on Figure 4-8. The first major changes occurred in 1915 when the San Antonio Zoo moved from the northwestern portion

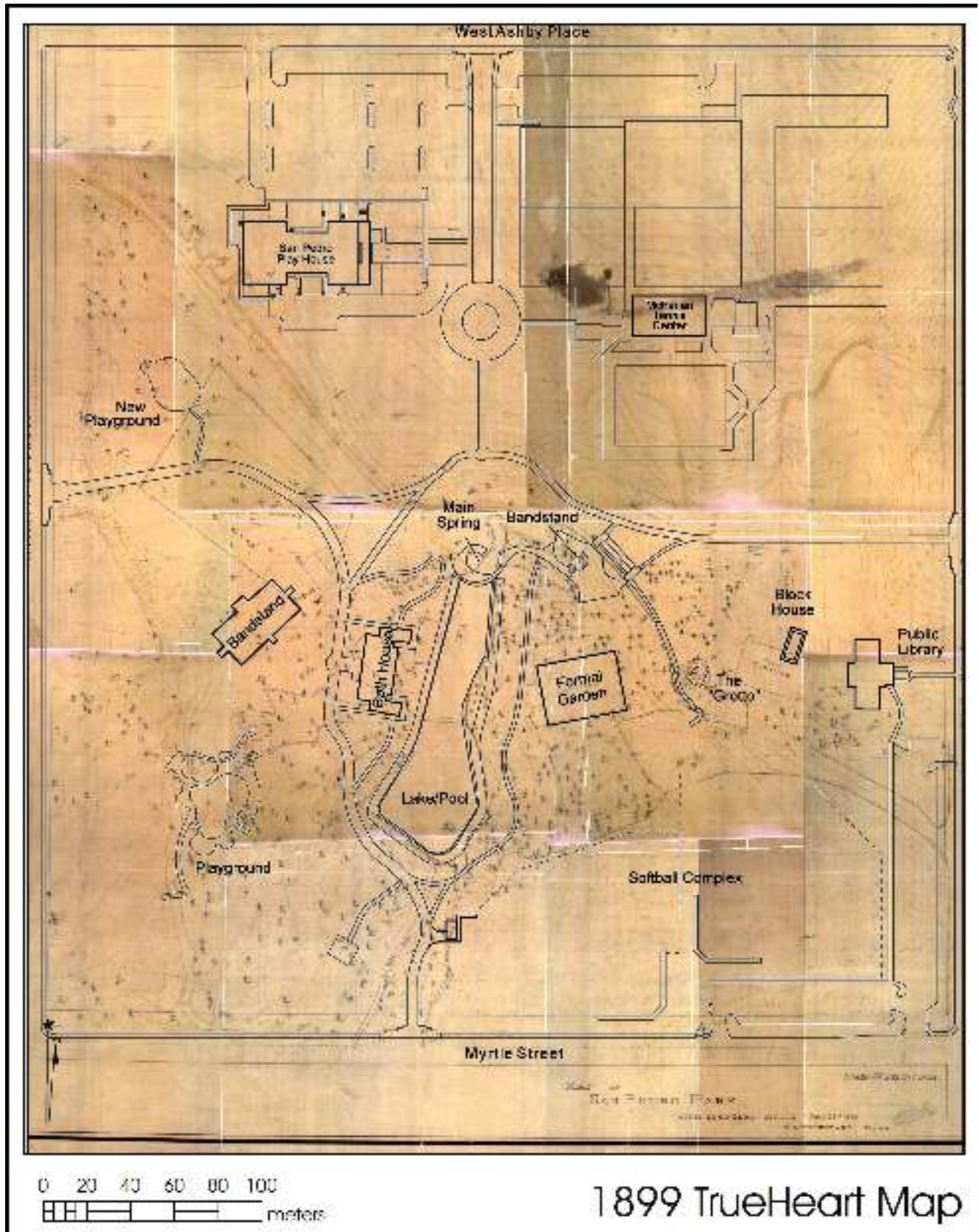

Figure 4-5. Trueheart Map of San Pedro Springs Park (1899), with major modern features identified for comparison. A copy of the map is on file at CAR-UTSA.

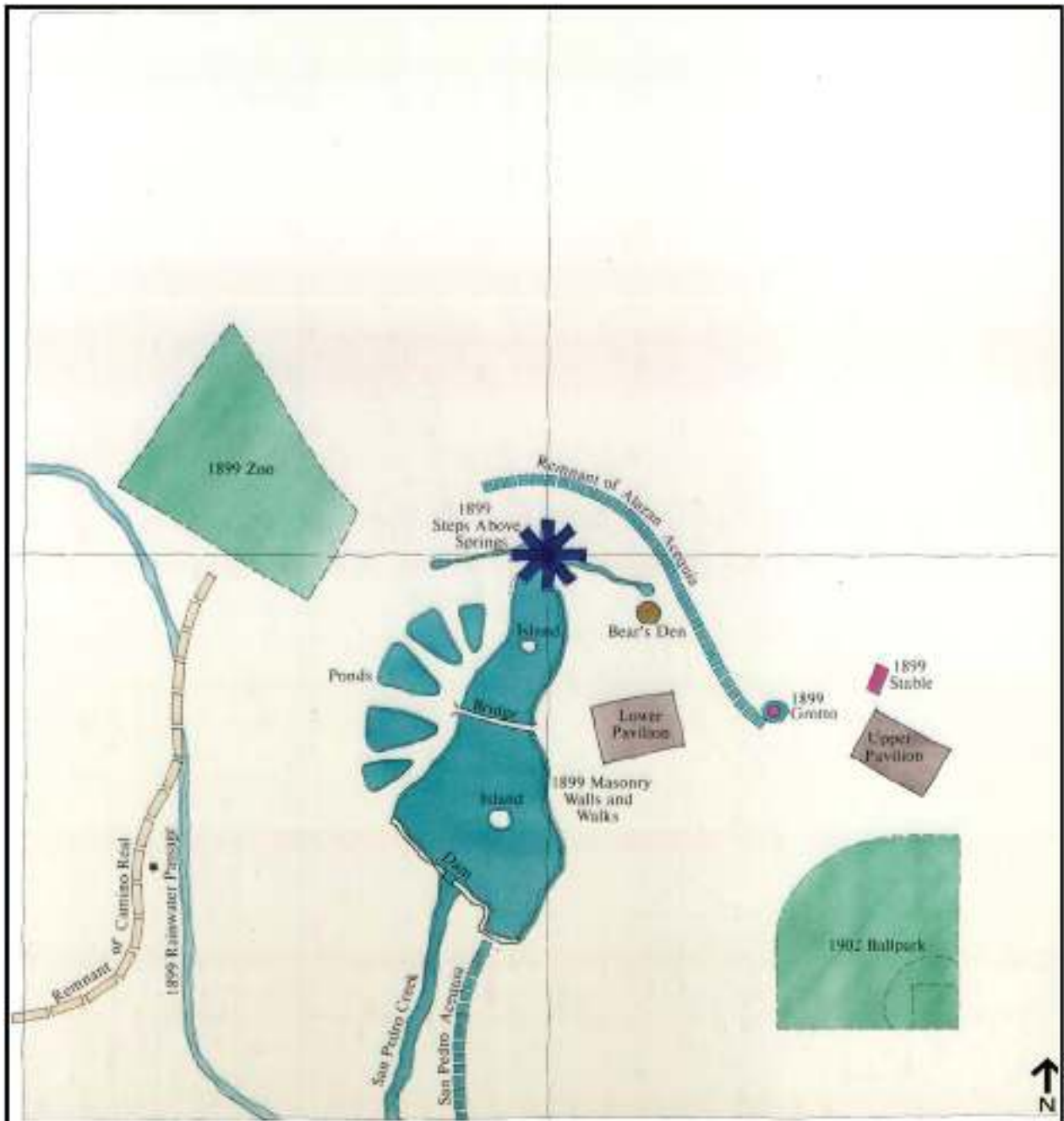

Figure 4-6. Map of San Pedro Springs Park showing major alterations at the beginning of the twentieth century (Beaty Palmer Architects 2013; see also RVBK 1994).

of the park to Brackenridge Park. At roughly this same time, a major drainage project, including “canals,” was initiated by the City to control flooding that was becoming more common as populations increased. As reported by the *San Antonio Light*, the “canal is five feet deep, thirty feet wide at the surface and ten feet wide at the bottom,” running primarily along the western side of the park (*SAL*, 17 January 1915). Remnants of that drainage canal are still visible today, and the canal is identified on the Figure 4-8 map as the “WPA-Era Stone-Lined Drainage Channel.”

In 1922, the City constructed a municipal swimming pool within the old lake bed (Figure 4-8) that was fed by the springs (Crook 1967). In 1929, both the first branch of the San Antonio Public Library and the San Antonio Theater, which subsequently became the San Antonio Playhouse, were constructed (Cox 1999). Several newspaper articles suggest work in the 1930s associated with “relief” efforts, and some of these efforts may be reflected in the Figure 4-8 designation of “WPA-Era Stone-Lined Drainage Channel” (*San Antonio Express [SAE]*, 4 August 1935). For example, Orchard and



Figure 4-9. Aerial photo of San Pedro Park in 2014 (Google Earth).

from Google Earth. The tennis complex now dominates the northeastern corner, with two softball fields in the southeast. The pool and support buildings dominate the southern center of the park. The San Pedro Playhouse and associated parking areas take up the northern area. Playgrounds, sidewalks, picnic tables, and the scars of old roads and ditches all attest to the wide variety of activities that were, are, and will be taking place within San Pedro Park. In closing this summary of park history, several landscape alterations that have dramatically shaped and influenced the archaeological record that was encountered in the park are emphasized.

The summary above clearly suggests the northeastern section of the San Pedro Park was dominated by a series of limestone ridges that may have extended out into the area near the spring (Figure 4-3). It is likely that the springs emanated at or near the base of those ridges. As some point in the nineteenth century, or perhaps earlier, the first of these landscape modifications, quarry activities, were initiated. In fact, at one time it appears that a commercial quarry was in operation at this location. These activities likely reduced these ridges. The construction of the McFarlin Tennis Center in the early 1950s seems to have removed more of this hill, though the complex

still rises above the surrounding landscape by several meters. Notations on the preconstruction 1899 Trueheart Map suggest differences between the northeastern corner of the park and the start of the springs may have been in excess of 17 m. Other than limited information on the presence of several “caves” in this portion of the park (see Figures 4-2, 4-3, 4-4, and Chapter 5), there is a lack of any details on what may have been on these ridges. These locations, overlooking the springs and above the “black dirt that always got so muddy” according to the *San Antonio Light* reporter (*SAL*, 4 July 1899), would have been well-suited for occupation.

The central portion of the park, including the areas around the springs, was extensively modified initially by Duerler’s construction and by the 1899 renovations. It is likely that during this period there was a substantial removal of upper sediment from the park, with the black dirt being replaced with “white dirt” that was compressed, and limestone “siftings” from the quarry being spread across sections of the park (*SAL*, 27 August 1899). As discussed in subsequent chapters, CAR archaeological excavations recovered clear evidence of the removal of upper deposits and a narrow, dense, limestone/carbonate dominated cap present in several areas. This most likely reflects these 1899 renovations to the

park. In effect, the 1899 work removed or displaced much of the Late Prehistoric, Proto-historic, and Colonial Period occupations from sections of the park.

These sets of alterations involved changes to water control features, specifically the eighteenth-century San Pedro *Acequia* and associated dam. The preconstruction 1899 map clearly shows the *acequia*, the dam, which is likely to be colonial in age, at the southern end of the lake, and a head gate at the head of the *acequia*. Houk (1999:23), based on overlays and backhoe trenching, concluded that much of the dam and colonial head gate were previously destroyed by the 1899 work as well as the 1922 swimming pool expansion. Houk (1999:23) reports that the San Pedro *Acequia* was closed around 1912 (RVBK 1994), and it is certainly not a prominent feature by 1915. The 1915 article in the *San Antonio Light* that discusses drainage improvements in the park suggests that it was closed at that time. The article has an accompanying map that fails to show the *acequias*, and though it has a short discussion of *acequias*, it does not mention those in the park (*SAL*, 17 January 1915). Finally, more recent, but less well-documented disturbances to the park are associated with the 1930s and work likely conducted by the WPA.

Chapter 5: Previous Archaeological Investigations at San Pedro Park

Raymond Mauldin, Stephen Smith, and Antonia Figueroa

This chapter provides a short summary of investigations into the historic and prehistoric archaeology of San Pedro Park. Several avocational investigations as well as more recent professional investigations are included. While summaries are available (see Meissner 2000a; Wadley and Tomka 2013), there are no comprehensive accounts of archaeological investigations, including this one, for San Pedro Park.

Avocational Exploration

San Pedro Park has a long history of avocational interests. This dates back to at least the early 1870s. As noted in the previous chapter, a series of caves were located on the bluff to the north of the springs. These have been the centerpiece of a variety of explorations.

In March of 1902, the *San Antonio Daily Express (SADE)* reported that a large cave was revealed during drilling and blasting operations in the northeast portion of the park. Human skeletal remains, ceramics, projectile points, and other artifacts were recovered from the cave (*SADE*, 30 March 1902). As noted by Barnes (1910), human remains were recovered from a cave entrance in the park during construction activities in ca. 1892. The newspaper article also describes a ca. 1871 exploration of a large cave opening located a quarter- to a half-mile north of the San Pedro Springs. A subterranean river, approximately six meters wide and running north to south, was reported as the source of the springs. Due to rapidly rising water from a heavy rainstorm, the investigation was not completed (*SADE*, 30 March 1902). The cave opening was subsequently sealed with a large boulder (Barnes 1910). Similar reports of burials within the northern portion of San Pedro Park were reported in March of 1909 in the *San Antonio Light (SAL)*, 4 March 1909; *SAL*, 7 March 1909). The *San Antonio Light* reports that at least six bodies were recovered, roughly 150 m due north of the bandstand area. In addition, "... war relics, articles of peculiar metal formation, spear and arrow points" were found (*SAL*, 4 March 1909). Following the story, crowds of onlookers were present, and "scores of small boys are constantly hunting for relics" (*SAL*, 7 March 1909).

Vocational archaeologists were also aware of the archaeological material in the park. Woolford (1935), in an address to Southwest Texas Archaeological Society, reported that there were "still many artifacts to be found" within the confines of San Pedro Park. C.D. Orchard collected a variety of artifacts from throughout the San Antonio area.

Orchard (Orchard and Campbell 1960) noted that in the early 1930s, he collected several pottery sherds from an "oval midden area having a maximum length of about 400 feet" (Orchard and Campbell 1960:7). The midden was located in the northwestern section of the park. He reports that the midden "was extensively damaged" in the mid-1930s and that "since then soil from other areas have been dumped" over this deposit (Orchard and Campbell 1960:7). Orchard subsequently donated his collection to CAR-UTSA, and those items that could be associated with San Pedro Park include a variety of flakes, four ground stone fragments, and several projectile points including Archaic age Gower, Bulverde, and Pedernales dart points, and Scallorn arrow points (Wadley and Tomka 2013:9). Notes that accompany the collection include a hand-drawn sketch that identifies several "midden" areas in the park. The exact date of the sketch is unknown, but the identified middens cluster to the east and north of the of the swimming pool area.

Professional Investigations

Mardith Schuetz of the Witte Museum formally recorded San Pedro Park as an archaeological site in 1966. A site designation, 41BX19, was entered into state records in 1981 for the park (THC 2013). Site 41BX19 is listed on the National Register of Historic Places (NRHP) and is a State Antiquities Landmark (SAL).

Anne Fox of CAR conducted the earliest professional investigation within the park. In 1977, she excavated a portion of the Alazán *Acequia* (Fox 1978:11-13). Fox's excavation provided an early description of the construction, as well as modifications. While a variety of excavations and archival research followed Fox's original work, most of this focused on areas outside of the park and involved documenting various sections of the Alazán and San Pedro *Acequias* (e.g., Cox 1986; Frkuska 1981; Labadie 1987; Nickels and Cox 1996; Uecker 1991).

In 1996, CAR staff, under the direction of Barbara Meissner, conducted backhoe trenching and shovel testing to locate the Alazán *Acequia* and assess the likelihood that future construction would seriously impact cultural resources on the western edge of the park, along North Flores Street (Meissner 2000a:17-41). Using shovel tests and several backhoe trenches in combination with the 1899 Truehart Map, Meissner located the Alazán *Acequia* in the northwestern

corner of the park. Most of the shovel tests contained cultural material, and while artifacts were recovered down to a depth of 70 cm below the surface (cmbs), disturbance was present (Meissner 2000a:17-29). Historic artifacts were concentrated in the upper two levels (0-20 cmbs), and the number of artifact decreased with depth. Prehistoric artifacts were concentrated in the lower five levels. In addition, most prehistoric material was present in the shovel tests located to the south, and those tests to the north along North Flores contained primarily historic material (Meissner 2000a:17-29). Meissner (2000a:41) suggested an intact prehistoric component in the southern section of the park at 20-40 cmbs.

In 1998, CAR conducted a damage assessment of construction work that occurred without archaeological oversight in the southwestern portion of the park adjacent to North Flores and Myrtle Streets (Houk et al. 2000). This was the general location identified by Meissner's earlier work as having intact prehistoric cultural deposits. The 1998 work included the excavation of five 1-x-2 m test units and 40 shovel tests in this area. That investigation found that grading and compaction had damaged the upper 50 cm of cultural deposits, primarily affecting Historic, Late Prehistoric, and transitional Archaic materials (Meissner 2000b:78).

In 1998-1999, CAR conducted a second project consisting of a pedestrian survey, shovel testing, and backhoe trenching within the park prior to the expansion of the swimming pool (Houk 1999). The result of that investigation indicated that large sections of park were disturbed. This included the area immediately to the south of the pool, where historic maps indicated that colonial age features such as the dam, head gate, and portions of the San Pedro *Acequia* might remain. In all, 44 shovel tests, with a minimum depth of 50 cmbs and a maximum depth of 60 cmbs, were excavated. Two backhoe trenches (BHTs) were excavated during the project. The results confirmed a high degree of subsurface disturbance within the upper deposits in most areas, with a mix of modern construction fill and other recent materials, a small amount of historic material, and prehistoric artifactual remains. With specific reference to the colonial head gate and channel, Houk (1999:20-22) concluded that features were "apparently destroyed" by construction, and the area filled with post-1950 material. With regard to the dam, he concluded, "no evidence of the colonial diversion dam was found in BHT 2, but it is possible that the dam, or a section of it, is preserved beneath the sidewalk" (Houk 1999:22).

In 2002, additional investigations occurred and consisted of monitoring of the installation of a sprinkler system, testing around the Block House prior to renovations of that structure, and shovel testing associated with the development of playground facilities (Zapata and Meissner 2003). The work by Zapata and Meissner suggests that the Block House was

probably constructed around 1850 (but see 1899 Trueheart Map, Figure 4-5). Shovel tests within the two playgrounds showed that the one nearest the North Flores entrance to the park was intact below 30-40 cmbs (Zapata and Meissner 2003:32). Work in the vicinity of the second playground, located in the southwestern area of the park, showed fill down to a minimum of 70 cmbs (Zapata and Meissner 2003:32).

In 2004, Uecker monitored the excavation of 19 pits for trees that were planted along North Flores and West Ashby Streets. He recorded no archaeological resources in that area and describes the sediments as "modern caliche and clay topsoil fill that contained no artifacts" (Uecker 2004:3). Uecker concluded this area was covered by "several feet" of "imported" fill which he attributed to work likely done in the 1930s (2004:3).

Finally, in January 2013, CAR monitored the installation of a moisture barrier and an associated drainage system along the north wall of the San Pedro Playhouse (Wadley and Tomka 2013). Trenching revealed extensive disturbance in this area, with cultural material being mixed. Some late 1890s material was collected from this area (Wadley and Tomka 2013).

Discussion

Figure 5-1 is a composite showing all of the previous archaeological investigations conducted at 41BX19 and the trenching that had been monitored for irrigation line installation. There is a dizzying amount of construction and previous work. The base layer of the map consists of five impact zones suggested by earlier work (see Meissner 2000c; Zapata and Meissner 2003). The zones were developed primarily by Meissner to facilitate management decisions within the park. The five zones, more clearly visible in Figure 5-2, have various recommendations tied to subsurface impacts. For example, no construction work is recommended to occur within areas that fall within Zone 1, the darker pink shade on Figure 5-2. This area has demonstrated significant deposits present. At the other extreme, Zones 4 and 5, identified in light yellow and gray on Figures 5-1 and 5-2, are suggested to not require testing (Zone 5) or to require testing only with significantly deep impacts (Zone 4). This is because these areas have been extensively disturbed or are presently occupied by facilities, such as the tennis complex or the swimming pool, which are in use.

As outlined in the following chapter, the current project investigated areas identified as Zones 1, 2, or 3. These three zones cover roughly 32.2 acres, or about 70% of the park. Areas within Zones 4 and 5 and those areas within Zones 1-3 that had existing features (e.g., sidewalks, gardens, electrical lines) were avoided.

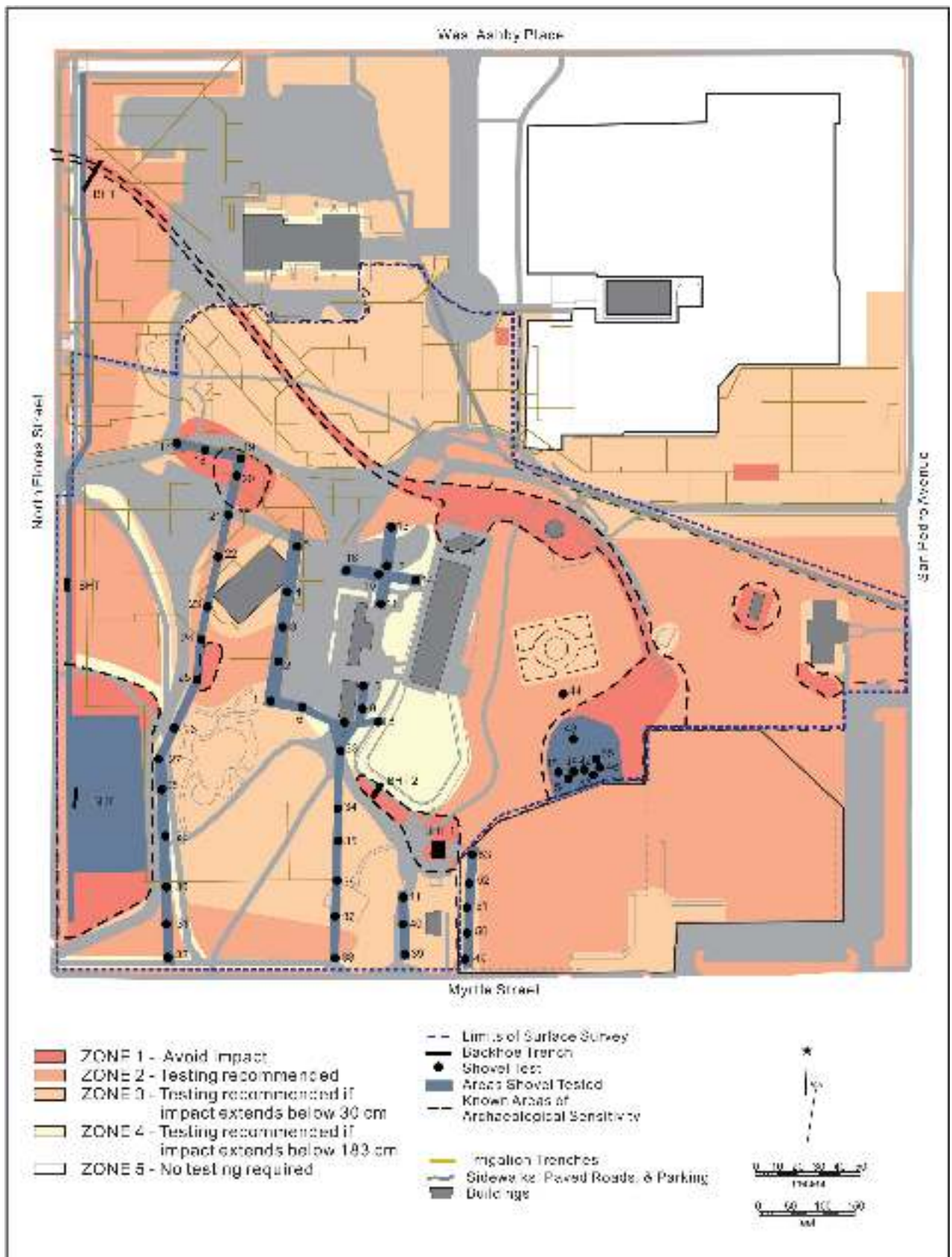

Figure 5-1. Composite map of the previous archaeological investigations conducted at 41BX19.

Chapter 6: Project Goals and Associated Field, Laboratory, and Curation Methods

Stephen Smith, Antonia Figueroa, Sarah Wigley, Raymond Mauldin, and Melissa Eiring

The review in the previous chapter clearly shows that while there has been extensive archaeological work in San Pedro Park since 1996, there has been no systematic and comprehensive testing across the entire park prior to the current effort. Sections of the park identified by Meissner (2000c) as archaeologically sensitive (Zone 1) have been tested, but Zones 2 and 3, which account for the majority of the area outside of buildings or other structures, have had little or no investigation (see Figure 5-2). A master plan for the long-term development and upgrades to the San Pedro Park was originally developed in 1992 (Beaty Palmer 2013; RVBK 1994), and over the last 20 years, several of the suggested upgrades in that document have been implemented. As outlined in Chapter 1, when the work for this project was initiated, the only identified impacts involved a trail system running along the perimeter of the park, primarily along the western side. However, the changes proposed in the 1992 Master Plan, as well as more recent updates (Beaty Palmer 2013), suggested the need for a more comprehensive investigation of all accessible areas of the park. Therefore, the current work was developed to be a comprehensive survey and investigation of the park.

The goals of the archaeological investigations that guided the project were to 1) identify and investigate archaeological deposits associated with colonial occupations, including any remnants of the San Pedro *Acequia*, dam, the villa, and the presidio, 2) investigate any other historic or prehistoric cultural deposits in the park, and 3) preserve artifacts and records of the investigation for future researchers. This chapter provides a summary of the field and laboratory methods, as well as the curatorial procedures, that were used in an attempt to accomplish these goals.

Field Methods

A variety of field methods were used to discover, assess, and document archaeological resources within the park. At the initial stage of the investigation, the level of known impact was limited to the construction of a pedestrian trail that will run along the northern, western, and southern perimeter of the park. This area was assessed by the Project Manager, who walked the area identified for the pedestrian trail (Figure 6-1). As outlined in previous chapters, this area has had a



Figure 6-1. Proposed trail system running along the western half of the park (base map courtesy of Beaty Palmer Architects 2013).

variety of intrusions, and sections of the area have been previously shovel tested (see Chapter 5). No artifacts were observed during this reconnaissance.

Following the walkover, and in anticipation of the upcoming project, CAR initially excavated a series of shovel tests across the available area of the park. Based on those results, a series of test units were then selected and excavated. Finally, two short backhoe trenches were excavated in one area to better define the extent of a prehistoric deposit. These efforts are briefly summarized below.

Shovel Testing

One hundred and eleven shovel tests were excavated across the park. The shovel testing had two goals: 1) to search for shallowly buried cultural deposits that may date to the Proto-historic and Historic Periods and 2) to identify the spatial distribution of artifacts across portions of the project area that had been poorly explored in the past.

The shovel tests were roughly 30 cm in diameter and excavated in 10-cm levels. All matrix removed from each level of each unit was screened through ¼-inch hardware cloth, and all artifacts were retained by their appropriate provenience in plastic bags with appropriate temporary tags. A standardized shovel test form was completed for each shovel test excavated. The form contains information related to the terminal depth of the shovel test, types of artifacts recovered in each level, and the characteristics of the strata that were excavated. Photographs were taken of representative shovel tests for documentation and reporting purposes. Soil samples were collected from most levels in all shovel tests and brought back to the CAR laboratory. All artifacts and organic samples recovered were also returned to the CAR laboratory for processing and analysis. The location of each shovel test was recorded using Trimble II Geo Explored Global Positioning System units. The data from the units will be marked on large-scale aerial photos of the project area as a backup.

Hand-Excavated 1-x-1 m Units

Once the shovel testing was completed, the Project Archaeologists and the Project Manager, in consultation with the former Principal Investigator, reviewed the distribution of positive shovel tests and the contents of each unit. Based on the materials recovered, the relative density of artifacts, and possibilities of features, these areas were identified to be targeted for hand-excavations. Locations with high artifact densities, clusters of artifacts that contained a high-to-moderate diversity of artifact types that were thought to be in

undisturbed or minimally disturbed contexts, were targeted for additional investigations.

CAR staff excavated 118 levels distributed in 11 1-x-1 m units across the park. Each 1-x-1 m unit was excavated in arbitrary levels that did not exceed 10-cm in depth, and sediment from each level was screened through ¼-inch hardware cloth. Soil samples were collected from each excavated level. Any encountered features were documented using standard archaeological procedures. This includes completion of feature forms, measured drawings, and photographs. The analyses included the recovery of a small soil column in selected locations collected for magnetic soil susceptibility analysis. Charcoal samples, when observed in context, were collected for possible radiocarbon analysis. All artifacts and organic samples recovered from test units were returned to the CAR laboratory for processing and analysis. The location of each test unit was recorded with a Total Data Station (TDS), and detailed contour maps of the surface for each excavation area were created.

Backhoe Trenches

To search for the location of the colonial dam and the San Pedro *Acequia*, CAR proposed to excavate three backhoe trenches. Due to the presence of utility lines in the area the use of backhoes to investigate for these water control features was not possible. However, one primary trench and one secondary backhoe trench were excavated to explore the extent of dense prehistoric cultural deposits encountered in one area of the park. These trenches were monitored during the initial work and photographed. Both walls of each trench were examined. CAR staff collected artifacts during the excavation of these trenches, and they were bagged with appropriate provenience information for laboratory processing. The location of each trench was recorded with a TDS, and a plan map was drawn. One section of the primary trench was profiled, and magnetic susceptibility samples were collected.

Laboratory Methods

All recovered artifacts, organic samples, and bone from shovel tests, hand-excavated units, and trenching were transported on a daily basis to the CAR laboratory for processing. Following each field day, bags were checked into the CAR laboratory. This involved verification of provenience information on all bags. Soil, charcoal, and bone were removed from plastic field bags. These organic samples were set out to dry if they were suspected of having high moisture content. After several days of accumulation, laboratory staff would wash and set out all artifacts collected to air-dry. Depending on their condition, bone samples were placed into new bags or, if covered with dirt, rinsed and air-dried.

In the case of some of the San Pedro Park materials, all artifacts and burned rock from a given area were covered in a thick layer of calcium carbonate that obscured determination of each individual artifact's form. This was especially the case for lower levels in Test Unit 4. Figure 6-2 shows a typical example, in which both faces of an artifact were covered, though one face generally had a heavier deposit. In these cases, artifacts were soaked in a weak acetic acid solution that was changed daily. Often several days of soaking were required to remove the coating. Once the collected material was reasonably clean and dry, they were separated into broad classes by material (bone, metal, ceramics, lithic debitage, burned rock, etc.) and then further partitioned for analysis.

Curation Methods

All records obtained and/or generated during the project will be prepared in accordance with federal regulations 36 CFR Part 79 and THC requirements for State Held-in-Trust collections. Field forms were printed on acid-free paper and completed with pencil. After quantification and completion of analysis, and in consultation with THC and the COSA Office

of Historic Preservation, artifacts possessing little scientific value were discarded pursuant to Chapter 26.27(g)(2) of the Antiquities Code of Texas. Artifact classes discarded on this project included most of the burned rock and snail shell, as well as unidentifiable metal, soil samples, and recent (post-1950) materials. Discarded materials were documented, and their counts were included in the curation documentation.

Artifacts and other samples retained are stored in 4-mil zip-locking archival-quality bags. Any material needing extra support was double-bagged, and acid-free labels were placed in all artifact bags. Labels were laser printed, and each contains provenience information and a corresponding lot number. Artifacts were separated by class and stored in acid-free boxes that were labeled with standard tags. Field notes, forms, photographs, and drawings were placed in labeled archival folders. Digital photographs were printed on acid-free paper, labeled, and placed in archival-quality page protectors to prevent accidental smearing or deterioration due to moisture. All artifacts recovered and not discarded as outlined above, as well as project related materials and documents, are permanently stored at the CAR's curation facility, along with a copy of the final report.

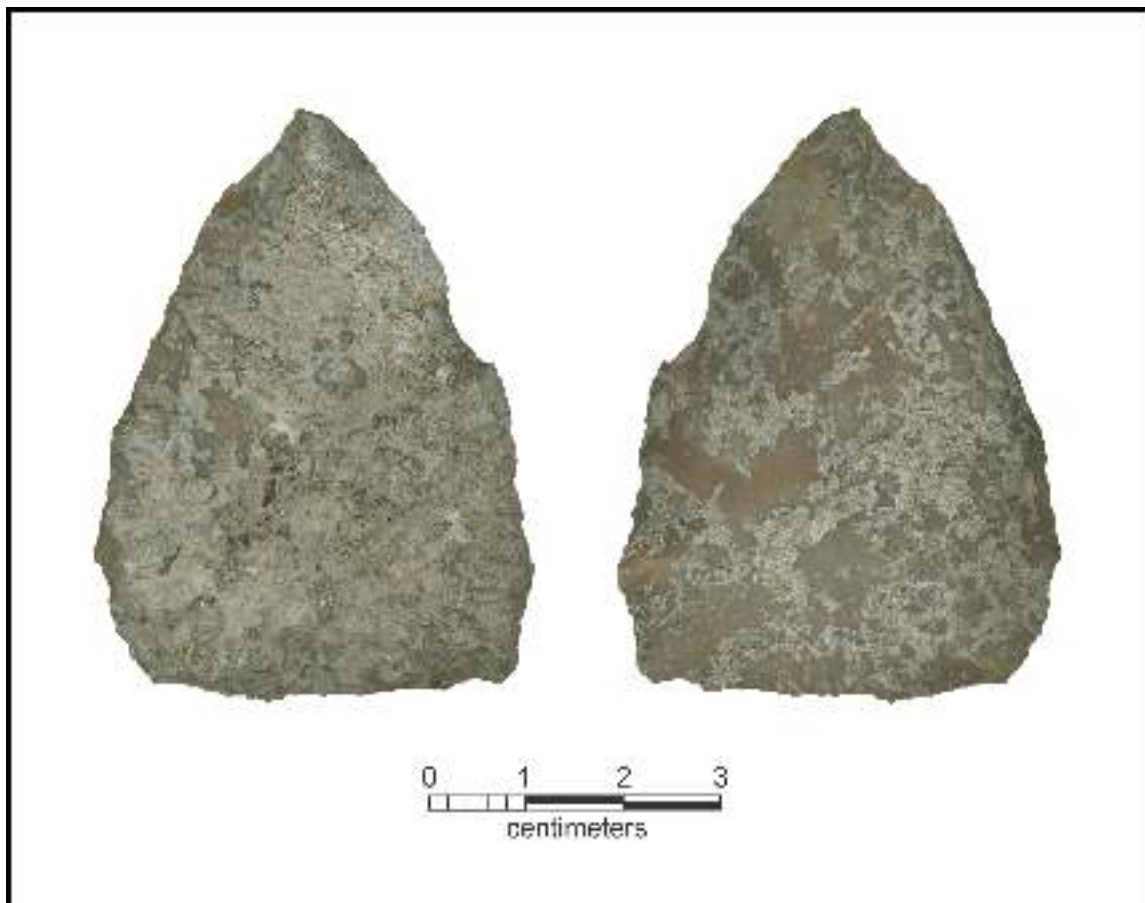

Figure 6-2. Calcium carbonate coating on a biface from 110-120 cmbs.

Chapter 7: Project Activities-Shovel Testing

Sarah Wigley, Raymond Mauldin, Stephen Smith, and Laura Carbajal

This chapter provides an overview of the results of shovel testing conducted by CAR at San Pedro Park. These data formed the baseline from which most of the additional excavations were conducted. These are discussed in the Chapter 8, which outlines the 1-x-1 m test units placed to explore concentrations, and Chapter 9, which provides a summary of the excavations looking for the San Pedro *Acequia*.

Shovel Testing

Figure 7-1 shows the location of the shovel tests (STs). CAR staff initially excavated 106 shovel tests with a target depth of 60 cmbs. These were numbered STs 1-105, with the 106th shovel test being designated ST 109. No shovel tests were numbered 106, 107, or 108. Shovel tests were placed throughout the park to identify areas of potential archaeological interest. They were excavated in all areas not covered by existing buildings, structures, sidewalks, concrete pads, formally designated spaces (e.g., gardens, softball infields), existing parking areas, or areas with known utility lines. In addition, the two playground areas were not tested, given that Zapata and Meissner had recently completed intensive shovel testing at these locations (see Zapata and Meissner 2003). Shovel testing efforts covered most of Zones 1-3 identified by Meissner (2000c), and all tests were excavated using the methodology outlined in the previous chapter. Following the initial 106 tests, an additional five shovel tests were excavated just north and east of ST 73 in the west-central portion of the park (see Figure 7-1). These tests, STs 110-114, were added to better define an area with burned rock. These five additional shovel tests were excavated to a terminal depth of 70 cmbs. Of the 111 shovel tests excavated on the project and shown in Figure 7-1, 85 reached a depth of 60 cm. This includes the five additional shovel tests, which were terminated at 70 cmbs. The remaining 26 shovel tests were stopped at depths above 60 cm due to various obstructions that were encountered.

Of the 111 shovel tests, 34 lacked any cultural material from 0-60 cmbs. Material may be present at depths greater than 60 cmbs in the five tests that went to 70 cmbs. Figure 7-2 shows the distribution of these tests. Most are concentrated in the southeastern quadrangle of the park, on or near the baseball fields. This suggests that fill may have been brought in for some of this area. Figure 7-2 also shows 15 shovel tests that have some clear indication of disturbance, as indicated by the presence of modern material (e.g., aluminum pull-tabs, bottle tops, glass, and a variety of plastics) in the deposits

at depths below 40 cm. Overall, 49 of the 111 tests (44%) were either negative or disturbed at depths below 40 cm. The distribution of these 49 is similar to that shown for the negative tests, suggesting that the much of the upper levels within the park represent recent fill or have been disturbed.

Table 7-1 presents a count of cultural material recovered from shovel tests that were distinguished between animal bone, historic/modern, and prehistoric material. On average, positive shovel tests recovered 18 items per shovel test. However, note that most of the material was concentrated in a handful of positive tests, with six shovel tests (STs 19, 30, 34, 72, 81, and 105) accounting for 42.5% of artifacts recovered.

The majority of the cultural material recovered from shovel testing was prehistoric. Prehistoric material includes burned rock (n=290), debitage (n=503), lithic tools (n=13), bone (n=ca. 154), and small amounts of mussel shell and charcoal. Historic and modern materials consists of glass (n=278), metal (n=141), brick (n=39), ceramics (n=23), and other miscellaneous material (n=43). While Native American ceramics were recovered from test excavations, the only ceramics found in shovel tests consisted of white earthenware and stoneware.

Consistent with the results suggested by earlier investigations within the park discussed in Chapter 5, there is evidence of significant below ground disturbance in the shovel test data. Figure 7-3 plots the density of modern, manufactured materials for these tests. This category includes a variety of artifact types, such as plastic, aluminum pull-tabs, various other metals (e.g., wire, bullet casing), and recent construction material (e.g., plaster, recent wire nails, concrete chunks, and tar paper). In all, this group contained 113 items. The bar graph in Figure 7-3, which has been corrected for the number of levels excavated, shows that while the highest density is in Levels 3 and 4 (20-40 cmbs) all levels have some of these recent materials present. However, a closer examination of the spatial distribution suggests that the deeper disturbance is limited primarily to a single shovel test (ST 105) located near the Tennis Center (see Figure 7-1). This shovel test had disturbance throughout the levels and accounted for 10 of the 14 items recovered from Level 6 in the shovel tests at the site. Eliminating this single shovel test produces the distribution in Figure 7-4, which provides a more representative picture of the depth of distribution. The figure shows a peak in Level 3, with a steady decline to Level 6.



Figure 7-1. The distribution of shovel tests excavated in the project area.

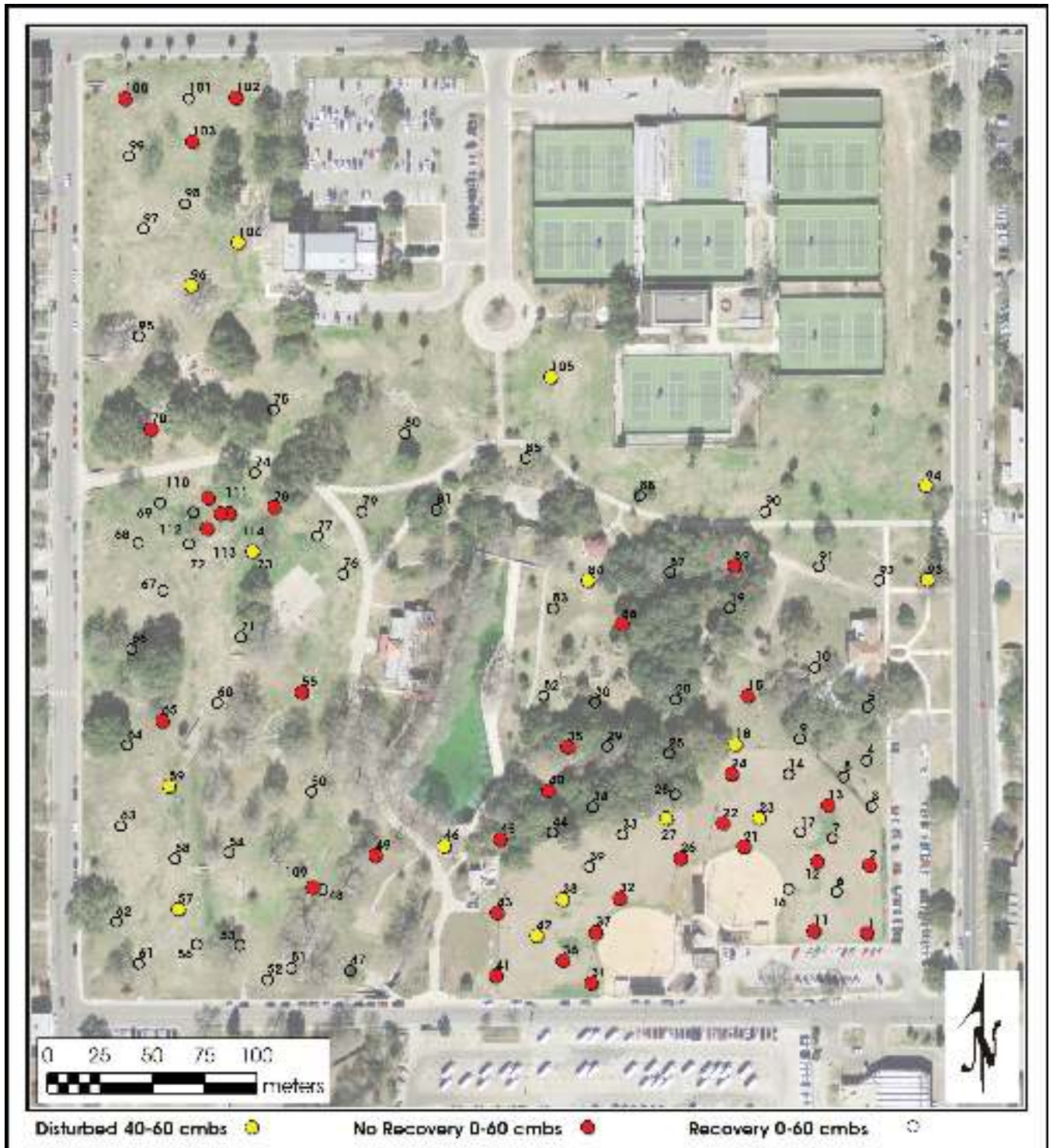

Figure 7-2. The distribution of shovel tests with no recovery (red), shovel tests with disturbed contexts from 40-60 cmbs (yellow), and tests with recovery and no deep disturbance (clear).

Table 7-1. Counts of Cultural Material Recovered from Shovel Tests

ST	Bone	Historic/Modern Material	Prehistoric Material	Total
3	3	9	15	27
4	0	0	1	1
5	0	1	20	21
6	0	1	0	1
7	0	1	4	5
8	0	1	12	13
9	0	2	3	5
10	2	0	0	2
14	1	2	0	3
16	0	0	1	1
17	0	6	0	6
18	0	6	30	36
19	29	32	4	65
20	0	1	13	14
23	0	16	2	18
25	0	6	9	15
26	0	1	0	1
27	0	11	9	20
28	0	5	16	21
29	0	0	12	12
30	18	28	69	115
33	0	1	0	1
34	15	5	197	217
38	0	4	22	26
39	0	2	9	11
42	0	2	0	2
44	0	5	1	6
46	0	18	4	22
47	0	0	1	1
48	0	4	0	4
50	0	8	3	11
51	48	1	0	49
52	14	8	1	23
53	1	7	0	8
54	0	3	0	3
56	0	2	0	2
57	0	2	0	2
58	1	0	4	5
59	1	9	2	12
60	0	2	0	2
61	2	9	4	15
62	0	0	6	6
63	2	0	4	6

Table 7-1. Counts of Cultural Material Recovered from Shovel Tests continued....

ST	Bone	Historic/Modern Material	Prehistoric Material	Total
64	1	4	8	13
66	0	3	8	11
67	0	3	9	12
68	0	11	2	13
69	0	0	4	4
71	0	51	5	56
72	0	0	77	77
73	0	2	8	10
74	1	0	3	4
75	0	3	2	5
76	0	1	0	1
77	0	2	0	2
79	1	0	26	27
80	1	2	8	11
81	0	3	87	90
82	0	0	13	13
83	0	16	7	23
84	0	20	1	21
85	0	11	3	14
87	0	1	0	1
88	0	9	1	10
90	0	14	2	16
91	0	7	0	7
92	0	8	2	10
93	0	22	5	27
94	0	22	1	23
95	0	1	2	3
96	1	4	2	7
97	0	1	0	1
99	1	25	1	27
101	0	1	0	1
104	1	5	1	7
105	7	51	10	68
110	0	0	14	14
111	0	0	2	2
112	3	0	7	10
113	0	0	5	5
114	0	0	2	2
Total	154	524	806	1,484

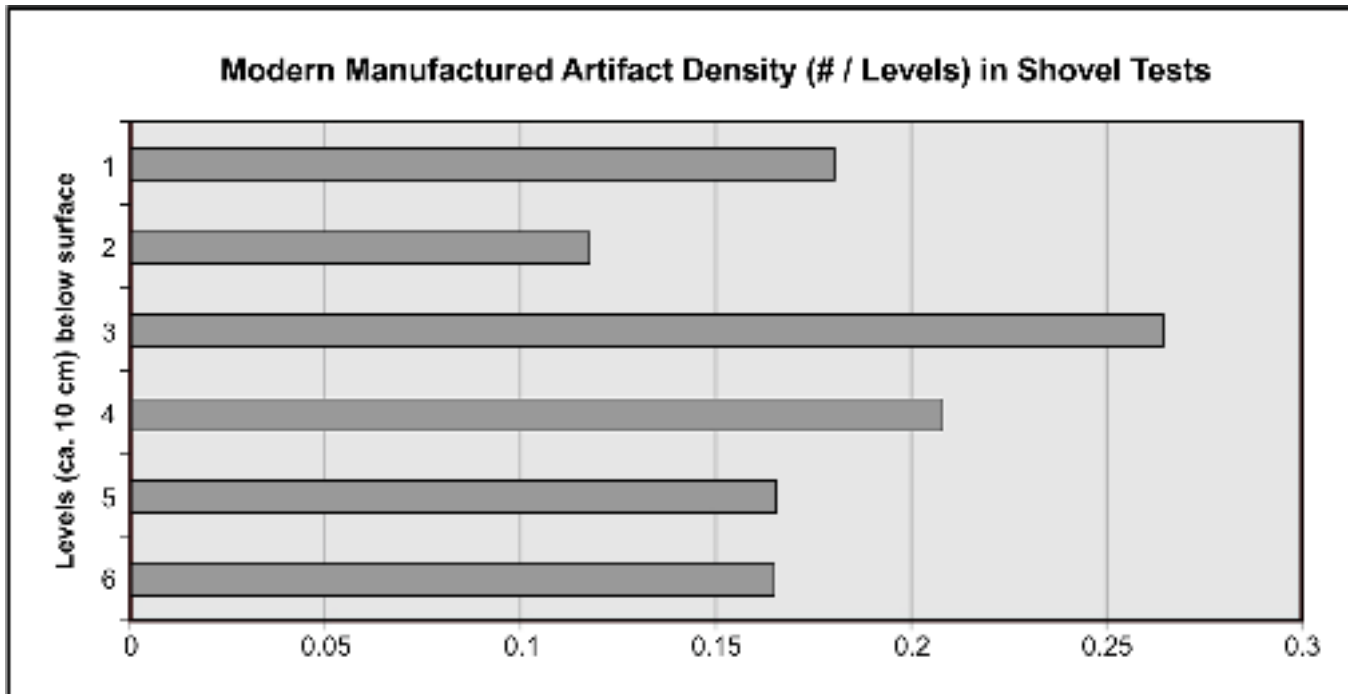

Figure 7-3. Density of modern manufactured material in San Pedro Park shovel tests.

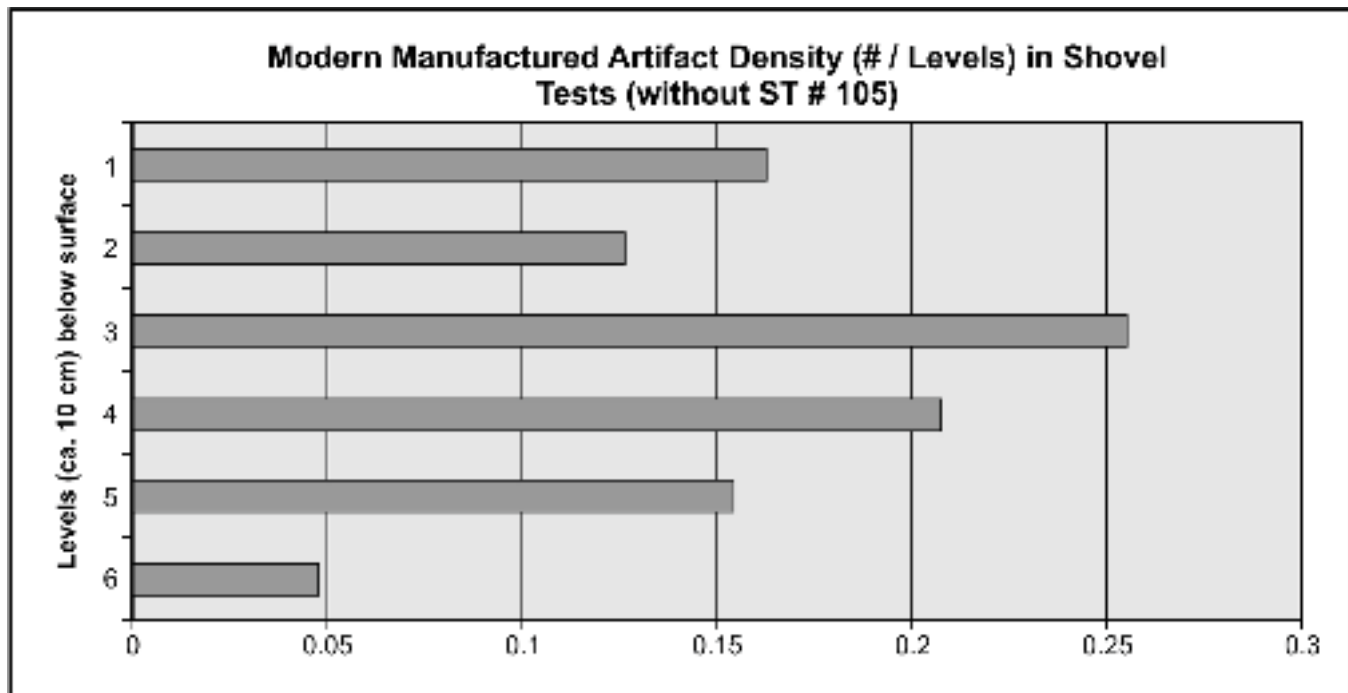

Figure 7-4. Density of modern manufactured material in San Pedro Park shovel tests without highly disturbed ST 105.

Figure 7-5 shows the vertical distribution of glass using a format similar to Figure 7-4. There were 249 pieces of glass recovered, providing a larger sample size than that shown in Figure 7-4. Glass density peaks in Level 2 and declines gradually, with a precipitous drop in Levels 5 and 6 (Figure 7-5). Certainly some of the glass recovered could date to the late nineteenth century, and it could be expected that some glass might be present at lower levels. However, a review of the collections suggests that most of the glass in the sample represents beverage containers, likely of recent origin.

Finally, Figure 7-6 presents the frequency of chipped stone recovered in shovel tests by depth. Just over 500 items are included in the graph. Like Figures 7-3, 7-4, and 7-5, the densities have been corrected for the number of levels excavated. The graph clearly shows increasing chipped stone density with depth, with the highest density in the lowest level at 50-60 cmbs.

When considered as a group, the vertical distributions of various classes of artifacts shown in Figures 7-3 through 7-6 clearly suggest that the upper levels are, in general, disturbed. This is not surprising given the history of the park and is consistent with the conclusions of earlier work. However, it is also the case that the lower levels tend to have lower frequencies of disturbance. Given the patterns of disturbance, a distinction between the upper levels (0-30 cmbs) and the

lower levels was made when considering the horizontal distribution of material within the park.

Figure 7-7 uses the Levels 1-3 distinction to highlight areas that have high levels of disturbance down to 30 cm. The figure plots the distribution of modern material (e.g., plastics, aluminum, concrete, plaster, recent metal, glass not assigned to a historic category) using a kernel density analysis in ArcGIS. Briefly, counts for each level of each shovel tests are used in combination with the Kernel Density tool in ArcGIS (2014; Spatial Analyst toolbox and extension) to create a series of raster-based density distributions for each artifact class. Most analyses used a consistent search radius of 65 m², natural breaks, 9 class breaks, and often made the lowest value class transparent for each raster to allow for visual reference. The figure shows that most of the area that was shovel tested had modern disturbance in the upper 30 cm.

Figure 7-8 focuses on the deeper (30-60 cmbs) deposits. Several areas with deep disturbances are clearly identified in Figure 7-8, though they tend to be more localized than the Figure 7-7 patterns, with more of a bull's-eye effect driven by a single test. Note that several of the deeper disturbance areas are not present in Figure 7-7. These include the areas just to the south of the existing swimming pool, near the public library to the west, and just east of the new playground. The patterns in Figures 7-3 through 7-8 suggest that the upper 30

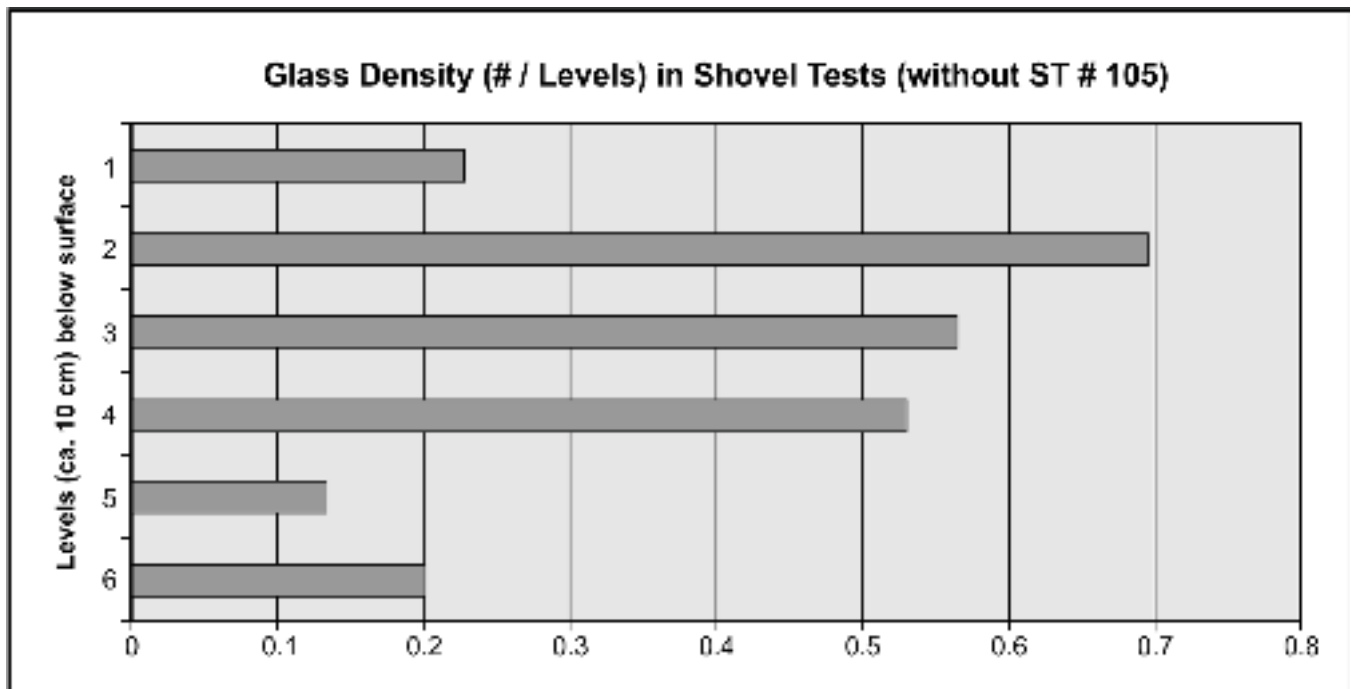

Figure 7-5. Density of glass in San Pedro Park shovel tests without highly disturbed ST 105.

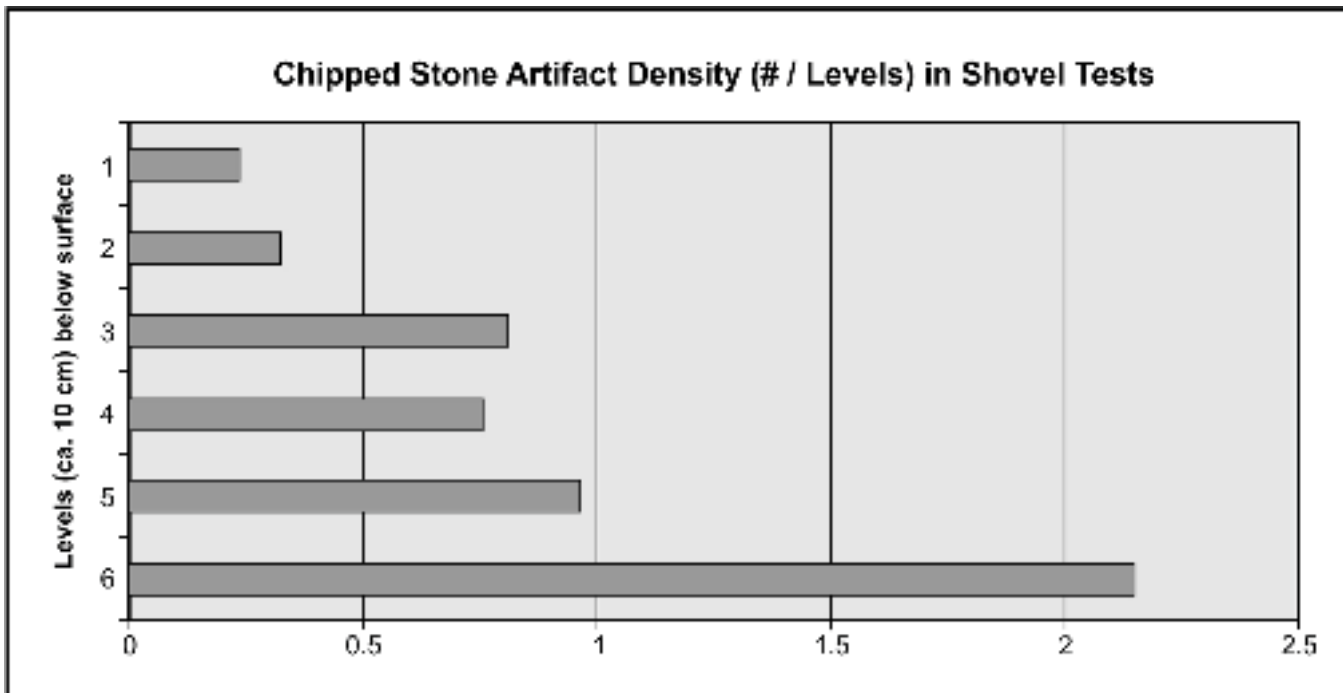

Figure 7-6. Density of chipped stone artifacts in San Pedro Park shovel tests.

cm across the park and several additional areas at depth (e.g. ST 105) are likely to represent a combination of relatively recent fill and heavy disturbance.

Figure 7-9 shows the density of chipped stone material recovered from across the park. Three areas of higher density are clearly visible. One peak is located near the bandstand, centered on ST 72 (Area 1, Figure 7-9). Excavations in this area, discussed in the following section, found this to be a part of Feature 1. ST 72 contained 58 pieces of chipped stone and several pieces of burned rock. The majority of this material was found in Level 6, which contained 49 pieces of debitage, a broken biface, and an edge-modified flake. This level also contained mussel shell and burned rock. After Feature 1 was uncovered in Unit 1 (see Test Unit Results, Chapter 8), STs 110-114 were excavated in order to establish boundaries for the feature. All were positive for lithic material and for burned rock below 50 cmbs.

Area 2 (Figure 7-9) was defined primarily by ST 81, which showed unusually high lithic density and was located near the main spring. ST 81 was noted as a possible burned rock feature. It was positive for debitage at every level and contained high densities of burned rock at Levels 2 and 3. Level 2 contained four pieces of debitage, and 395 grams of burned rock, and two cut nails. Level 3 contained 28 pieces of debitage, 379 grams of burned rock, and a single Scallorn projectile point. Three pieces of debitage and one piece of clear container glass

were found in Level 4. ST 81 was terminated at 35 cmbs due to obstruction by a large tree root.

The last area identified in Figure 7-9, Area 3, was located north of the baseball fields and close to high density returns originally found by Houk (1999; see also Chapter 5). The area showed a wider distribution than the other areas, with the high artifact densities in STs 30, 34, 5, and 18. Levels 2-4 of ST 30 contained large amounts of container glass ($n=26$) and accounted for the high-density peak in Figures 7-5 and 7-6. Level 4 also contained small amounts of bone, burned rock, and debitage ($n=13$). Levels 5 and 6 contained no glass but were positive for bone, burned rock, and debitage. Level 6 contained roughly 69 grams of burned rock, 34 pieces of debitage, a single untyped biface, and some snail. ST 34 was included in the same high-density area. Container glass ($n=5$) was found in Levels 1-4 of ST 34, and it was noted that Levels 1-5 appeared to be disturbed. Levels 2-4 contained bone, 67.4 grams of burned rock, and 25 pieces of debitage. No glass was recovered in Levels 5 and 6. Level 5 contained burned rock and 49 pieces of debitage. Level 6 contained bone, burned rock, 32 pieces of debitage, and an untyped biface. Slightly to the east of this area of high density, but within the same distributions, were STs 5 and 18. Both showed moderately high amounts of lithic material.

Areas 1 and 3 appear to have deeper deposits reflecting chipped stone and burned rock. This can be seen more clearly in Figure 7-10, which focuses on prehistoric material and shows the distribution within Levels 5 and 6.

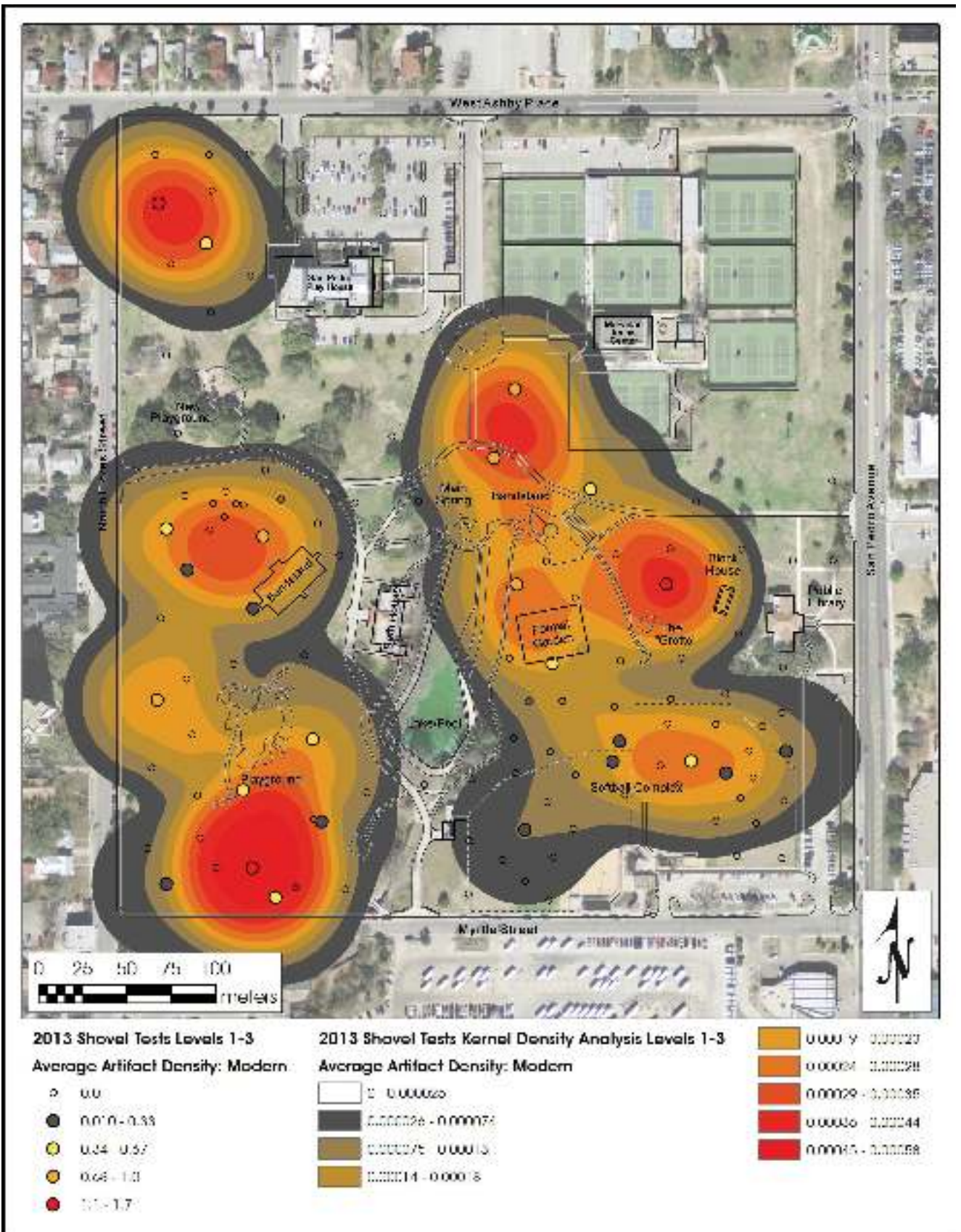

Figure 7-7. Kernel density map of modern material distribution in shovel tests, Levels 1-3, San Pedro Park.

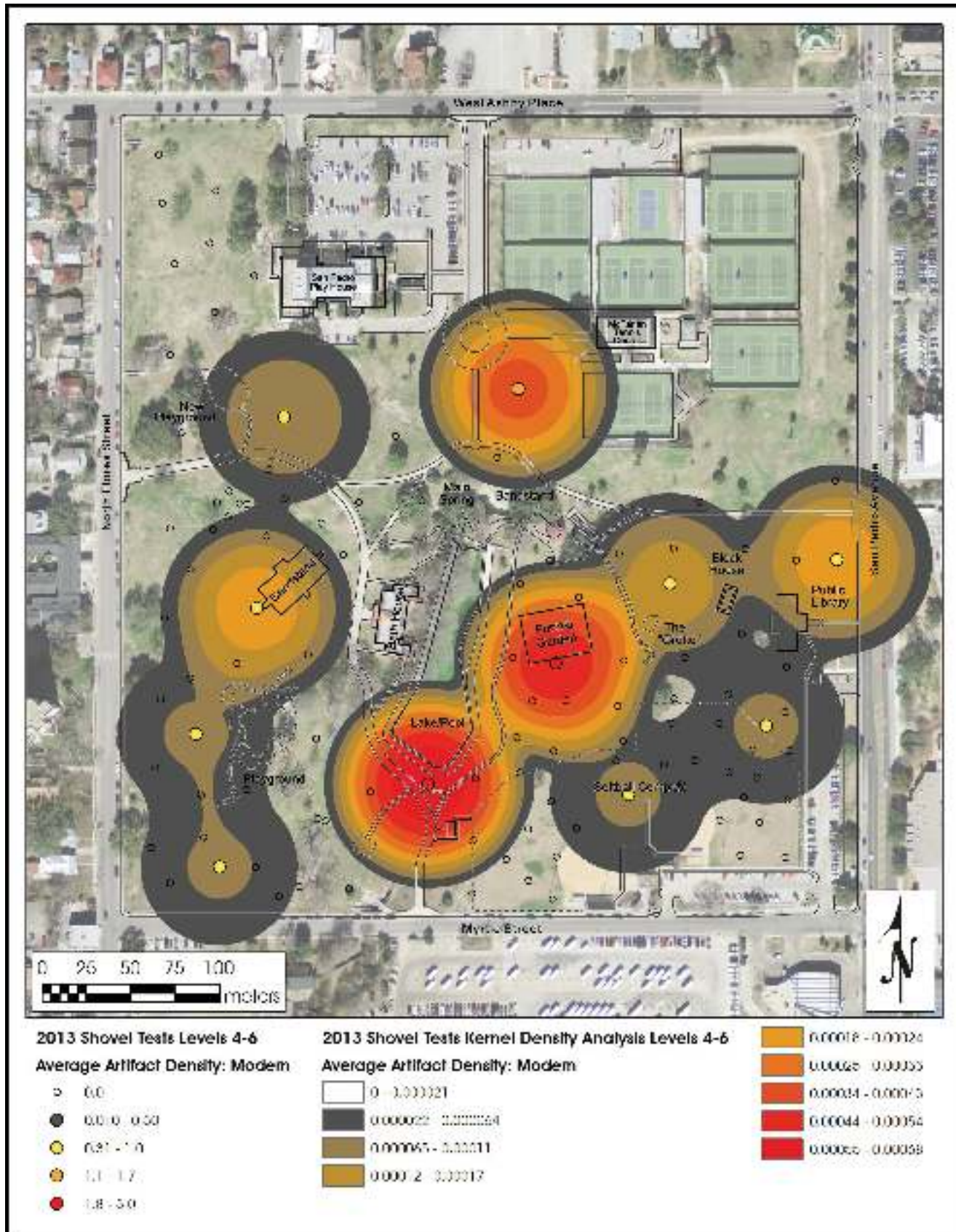

Figure 7-8. Kernel density map of modern material distribution in shovel tests, Levels 4-6, San Pedro Park.

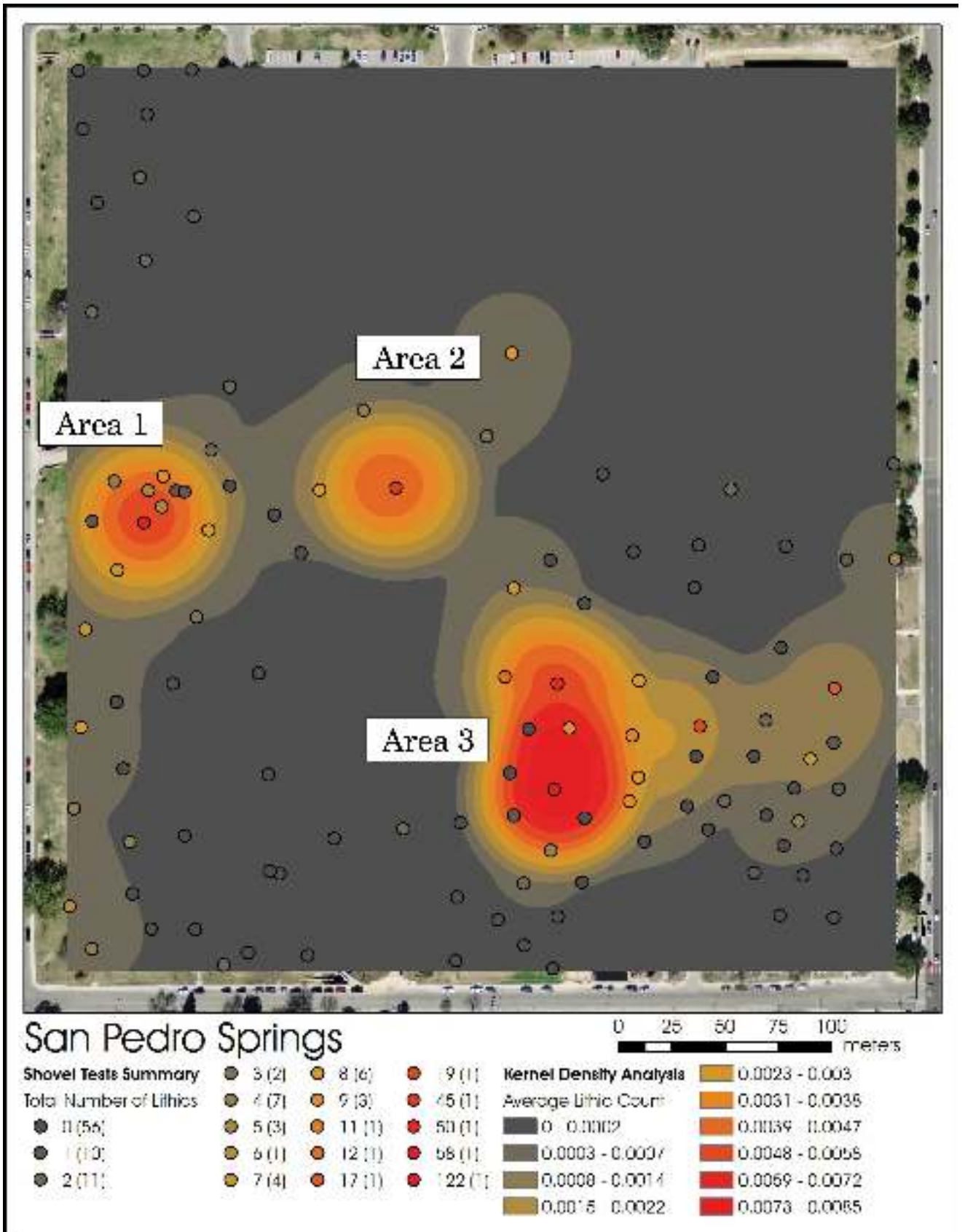

Figure 7-9. Kernel density map of chipped stone material distribution in shovel tests, Levels 1-6, San Pedro Park.

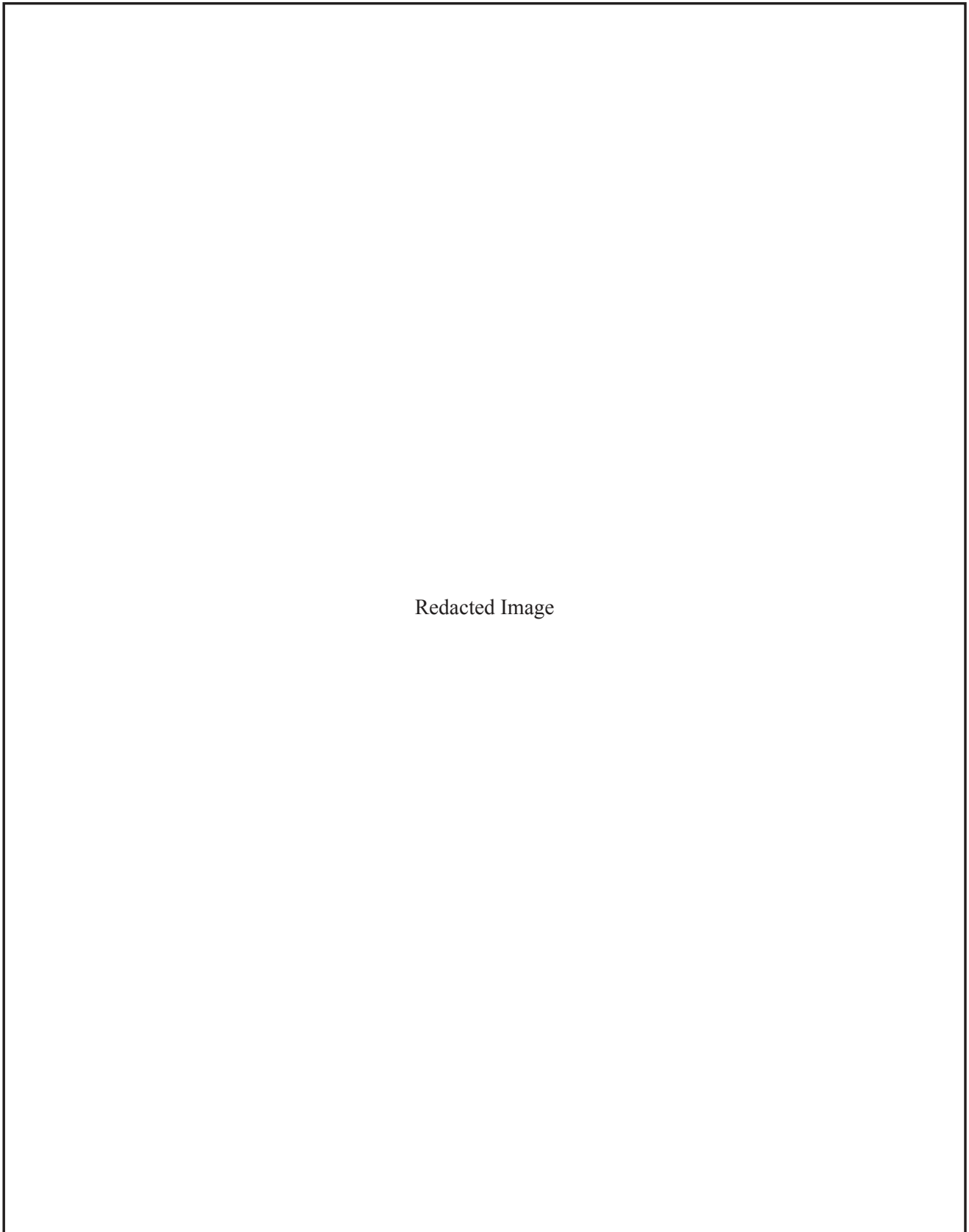

Figure 7-10. Kernel density map of prehistoric material distribution in shovel tests, Levels 5 and 6, San Pedro Park.

Summary

The shovel test data suggests that the upper surface across the park is likely disturbed down to at least 30 cm in most areas and down to 60 cm in others. Given the background presented in Chapter 4, this is not surprising. The shovel testing identified several areas that have high densities of

chipped stone, burned rock, and animal bone that likely date to the Prehistoric Period, though Proto-historic Period deposits could also be present in these areas. The distributions of lithic material were the primary data set used to identify several areas that were further explored with test units (TUs). The following chapter provides information on the excavation and results of the test units.

Chapter 8: Project Activities-Test Units and Backhoe Trenches

Raymond Mauldin, Stephen Smith, Antonia Figueroa, and Laura Carbajal

This chapter provides an overview of the results of unit and backhoe testing at San Pedro Park. Using the shovel test results presented in the previous chapter, six areas were identified and subsequently investigated through excavations and, in one case, backhoe trenching. A seventh area was also investigated through excavation, but the identification and decision to excavate in this area was defined more by archival research than by shovel testing. Chapter 9 discusses those archival investigations.

Testing Areas

Figure 8-1 shows seven different areas that were explored at various intensities with hand-excavated units overlaid on a modern aerial photo with a 0.3-m contour. Figure 8-2 shows the same map areas, but the areas are overlaid onto the general topography derived from the 1899 Trueheart Map presented in Chapter 4. Contours are generated based on

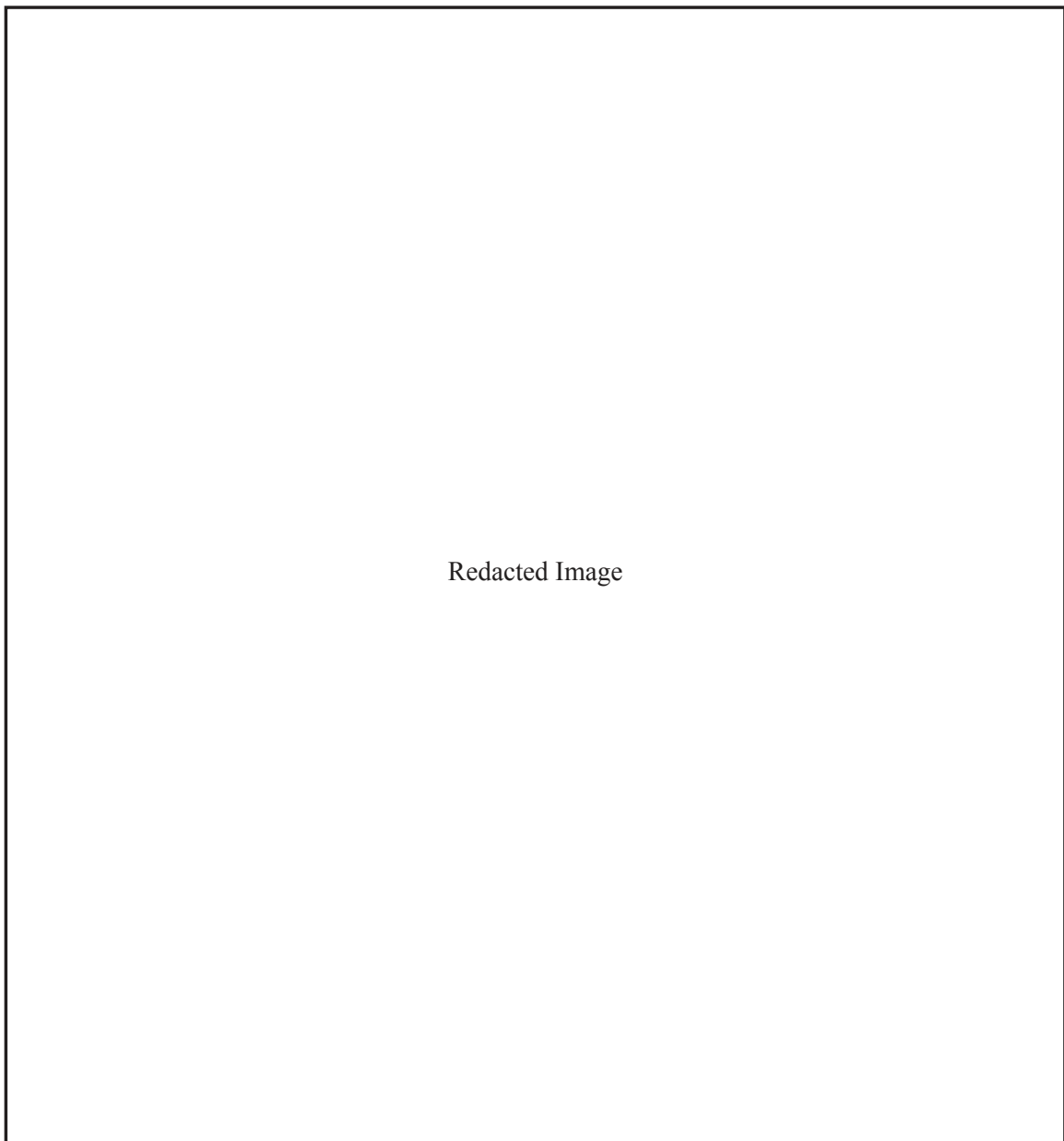

Figure 8-1. *Contour map of San Pedro Park with individual testing areas identified by map reference.*

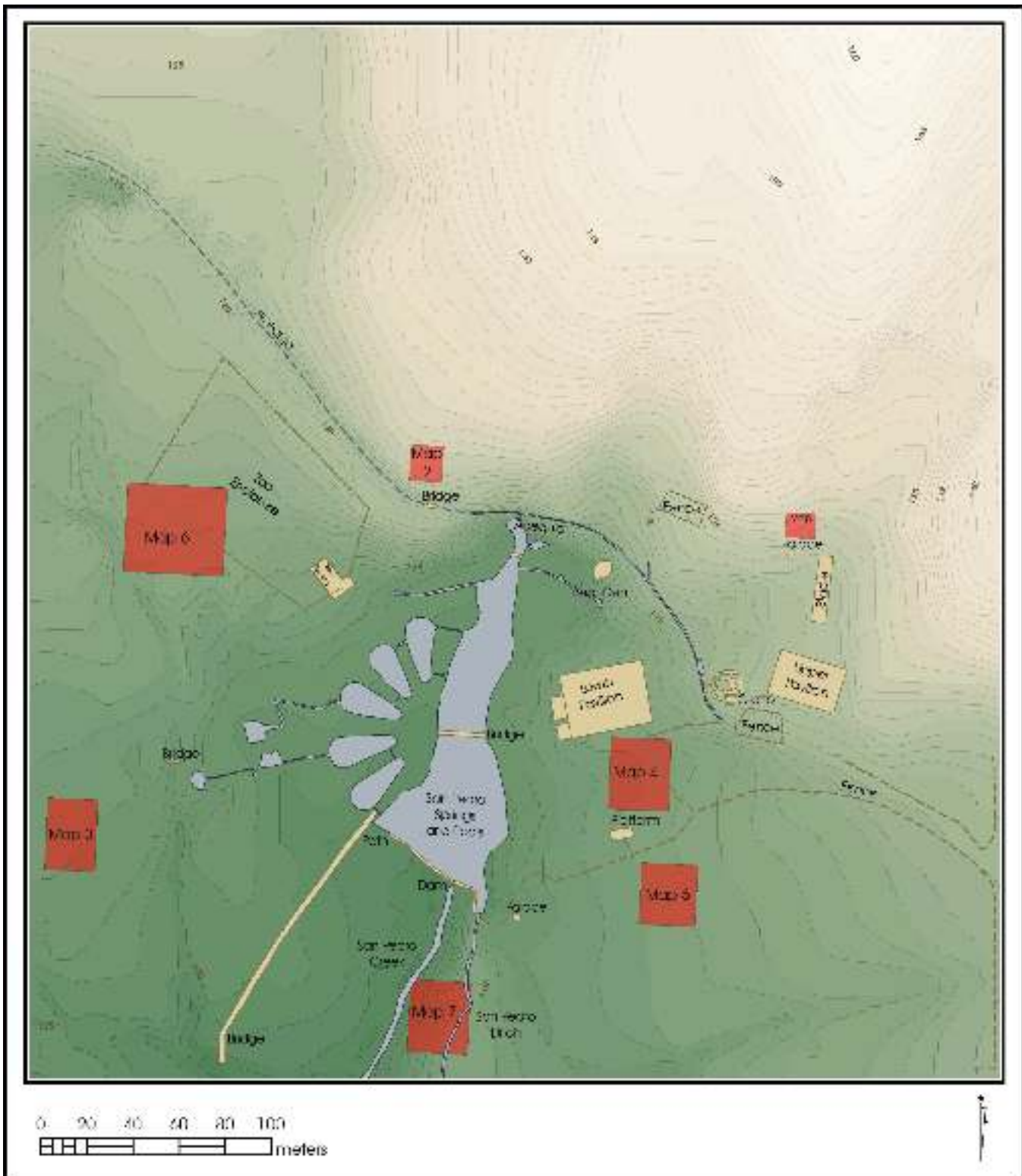

Figure 8-2. Contour map of San Pedro Park with individual testing areas identified by map reference. Base map is the 1899 Trueheart Map.

3-m increments from that map, and the historic features and buildings identified as present in 1899 are shown along with the testing areas. This chapter focuses on the areas identified as Maps 1-6. Within these six areas, nine 1-x-1 m units, designated TUs 1, 2, 3, 4, 5, 6, 7, 10, and 13, were excavated using procedures discussed in Chapter 5. Two 50-x-50 cm test units, designated TUs 11 and 12, were not screened and were excavated to facilitate exploration of deposits in the Map 4 area. Maps 1, 2, and 3 cover areas around TUs 7, 3, and 2. Map 4 covers the area around TU 4 (Figure 8-1) and also contains the two 50-x-50 cm units (TUs 11 and 12), and two backhoe trenches. Map 5 covers a single 1-x-1 m unit, TU 13. Finally, Map 6 contains TUs 1, 5, 6, and 10 (Figure 8-1). Each of these excavation areas are discussed below, including a summary of the rationale for the selection as well as the results. Additional information on specific artifact types is discussed in Chapter 10. When present, the radiocarbon dates are listed. Additional information of these radiocarbon dates can be found in Appendix A. These artifacts and respective dates are also discussed in Chapter 11 in the context of the assessment of the integrity of deposits.

Map 1/Test Unit 7

The Map 1 area that contained TU 7 was placed near ST 90, which had recovered some glass and noted a possible wooden beam in a portion of the shovel test. In addition, Zapata and Meisner (2003:20-21) had noted a concentration of historic material, dating potentially to the late nineteenth century, in a sprinkler trench they monitored in this area. TU 7 was excavated to a terminal depth of 70 cm below the datum (cmbd) in five levels, with the removal of 0.51 m³ of soil. Figure 8-3 shows the unit location, and Figure 8-4 shows a photograph of the completed test unit. Three soil strata were noted during excavations that included a very dark gray (10YR 3/1) silty clay, a lithic yellowish brown (10YR 6/4), and dark gray silty sandy clay. Modern material and prehistoric material were present throughout the test unit.

Table 8-1 gives a description of the cultural material recovered from TU 7. Levels 1 and 2 contained few artifacts, including bone, debitage, modern ceramics, glass, metal, charcoal, and brick and concrete material. There was an

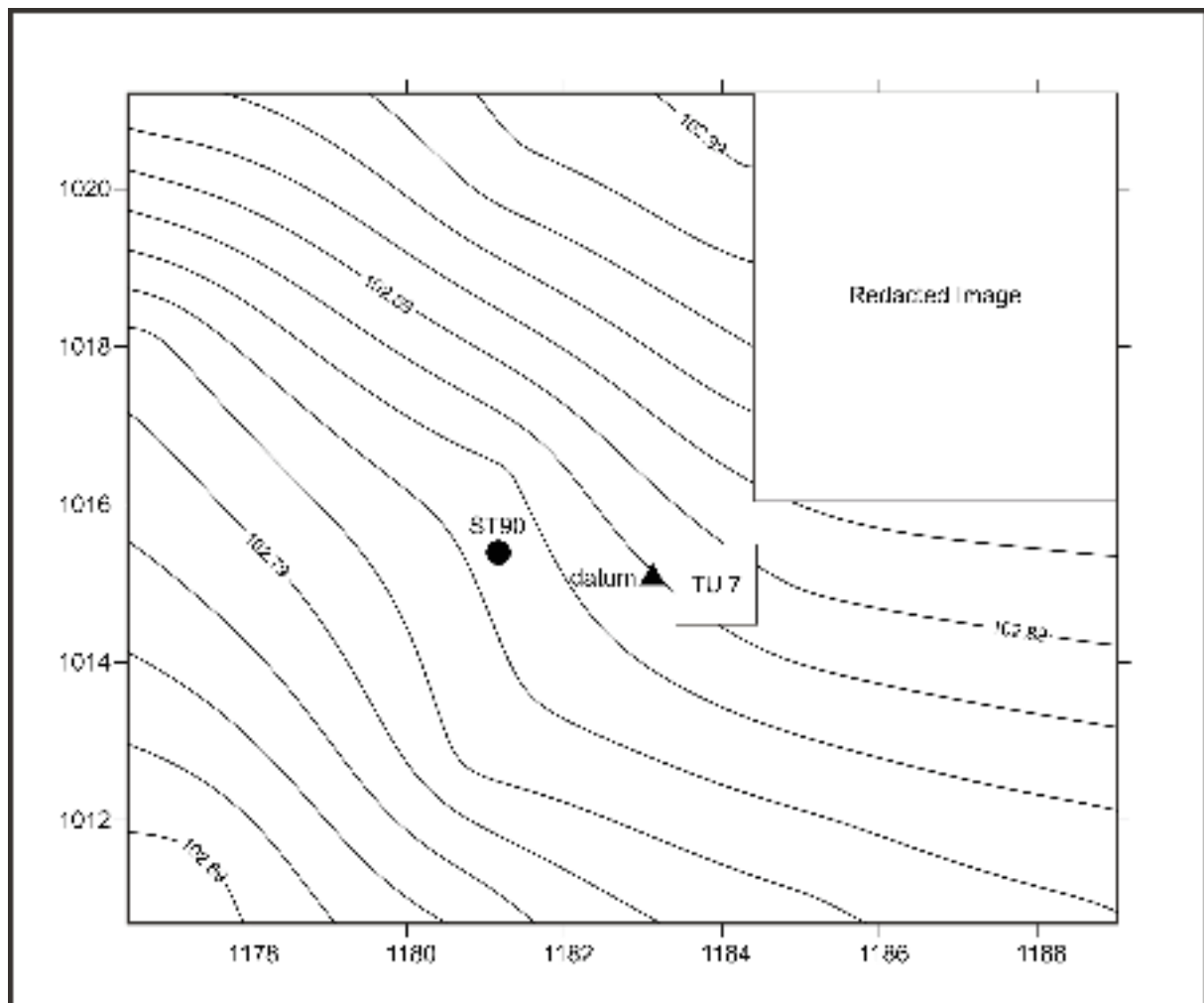

Figure 8-3. Test Unit 7 in Map 1 area. Inset shows area location on Figure 8-1.



Figure 8-4. Photograph of TU 7, Level 5. Note limestone bedrock floor.

Table 8-1. Artifacts Recovered from Test Unit 7

Level	Bone	Burned Rock	Ceramics	Charcoal	Debitage	Glass	Construction	Metal	Other	Total
1			1		2	2	1			6
2	7			1	4	8	3	8		31
3	8		6		18	52	10	12	10	116
4	32	5	10		10	47	4	33	2	143
5	3		4		3	14	1	5	4	34
Total	50	5	21	1	37	123	19	58	16	330

increase in prehistoric material (debitage and burned rock) in Levels 3 and 4. However, there was a presence of bone, glass, sewer pipe, metal, and historic ceramics that included white earthenware (n=7) and stoneware (n=2). There was a decrease of material in Level 5, with one piece of stoneware, bone, glass, debitage, metal, and unidentified construction material. The beam was determined to be a tree root.

Map 2/Test Unit 3

TU 3 was excavated to explore the concentration identified in shovel testing as Area 2 (see Figure 7-7, Chapter 7). This concentration was primarily the result of recovery from Level 3 (20-30 cmbs) in ST 81 of 28 pieces of debitage, 27 pieces

of burned rock, and a Late Prehistoric (Scallorn) projectile point. TU 3 was positioned roughly 10 m to the north of ST 81 (see Figure 8-1, Map 2 area).

Three levels were excavated before encountering an uneven limestone slab that appears to reflect bedrock at roughly 32 cmbs. There were disturbances within the levels, including a section of conduit associated with an electrical line in the initial level. Overall, roughly 0.34 m³ of sediment were removed and screened before the limestone bedrock was encountered. Table 8-2 presents the artifacts recovered in this shallow unit. While the number of debitage pieces recovered is relatively high, glass, a variety of metal (including both cut and wire nails), and brick/tile fragments were also present. A

Table 8-2. Artifacts Recovered from Test Unit 3

Level	Debitage	Burned Rock	Fauna	Glass	Metal	Brick/Modern	Other	Grand Total
1	13	1	2	1		3		20
2	51	8		13	40	15	2	129
3	34	1	1	1	7			44
Total	98	10	3	15	47	18	2	193

two-hole, shell button and a single piece of white earthenware ceramic were also recovered from this unit.

Map 3/Test Unit 2

TU 2 was located along the western edge of the southern portion of the park (Figure 8-5). The unit was excavated in 11 levels (Figure 8-6) that resulted in the removal of 1.13 cm³ of soil. The excavation of TU 2 revealed modern, historic, and prehistoric material (Table 8-3). A single radiocarbon date on bison bone collagen (CAR 344; see also Appendix A) from Level 2 produced a corrected date of 158 +/- 23 radiocarbon years before present (RCYBP). Calibrated with OxCal (Bronk Ramsey 2009) and using the two-sigma range, the most probable (40.2%) date range is from AD 1723 to 1785 BP, with a 16.2% probability that the date falls between AD 1666 and 1698. While more recent calibrated ages, including a post-AD 1916 date are possible (see Appendix A), it is likely that this bison bone collagen dates to the end of the Proto-historic or the beginning of the Colonial Period.

As shown in Table 8-3, the upper levels of this test unit also produced a high frequency of glass, with small amounts of metal, and a single piece of plastic. Glass from the unit was primarily clear and amber, and patina was noted as present on glass in these upper glass deposits. A single piece of plastic, classified as Other in Table 8-3, was recovered from Level 3. Prehistoric material from the unit included burned rock, bone, a Native American ceramic,debitage, and one biface. There was an increase of prehistoric material in Level 3 (see Table 8-3) that includeddebitage (n=287), burned rock (943 g), one projectile point (Edwards) dating to the Late Prehistoric, and one biface. However, there was still the presence of a small amount of historic material in the form of clear glass (n=3) in Level 4. Cultural material decreased through the remaining levels. Prehistoric material was present in small quantities at these lower depths. In addition, a single piece of glass was recovered in Level 6. Levels 7-9 had minimal content. No artifacts recovered from the two lowest levels.

Based on the Table 8-3 data, the upper two levels in this unit appear to be mixed. This mixing appears to include the Level 2, the recovery context for the bison bone that produced a probable Proto-historic/Colonial Period date. However, Figure 8-7, which presents a profile of the unit, suggests

that any conclusion that the bison is out of context may be premature. The upper sediment, Layer 1, was a dark brown (10YR 3/3) clay loam above a mottled (10YR 8/1, 8/3) soil with 80% gravel. This mottled deposit, Layer 2, represents recent fill deposited over native sediment. The excavation notes, as well as the profile drawing, suggest this recent fill, which ended between 35-40 cmbd across the unit, dominated the initial 5 cm of Level 2 (30-40 cmbd; 10-20 cmbs). The last few centimeters of Level 2 sampled the underlying Layer 3, a soft, black (10YR 2/1) clay loam that eventually shifted to a dark gray (10YR 4/1) with depth. With the 10-cm arbitrary excavation levels, it is impossible to say with certainty if the dated bison was recovered from stratigraphic Layer 2 or 3. However, given the overall pattern within the unit, the nature of stratigraphic Layer 2 (Figures 8-6 and 8-7), and the dramatic increase in bone and chipped stone from excavation Level 3, which was completely within Layer 3, it is likely that the dated animal was recovered from Layer 3. As discussed in Chapter 11, there is a reasonable possibility that this area may contain intact proto-historic/colonial deposits. If so, these deposits have the potential to yield significant information on a time period that, at least from an archaeological perspective, is not well documented.

Map 4/Test Unit 4

TU 4 was the only screened test unit in this area (Figure 8-8). Subsequently, CAR staff did excavate two intersecting backhoe trenches, two unscreened 50-x-50 cm units (TUs 11 and 12), and several auger holes in the bottom of these units to better define the distribution of cultural material. TU 4 was excavated in 15 levels to a terminal depth of 170 cmbd, and roughly 1.5 m³ of soil was removed from this unit. This unit has a high density of artifacts, with over 5,000 artifacts per m³.

As seen in Table 8-4, the upper levels of this unit contained disturbances associated with recent use, including chunks of asphalt. Figure 8-9 clearly shows these intrusions, which are also drawn in the profile view (Figure 8-10). Levels 1-5 contained few prehistoric and historic artifacts. An increase in prehistoric artifacts started abruptly in Level 6 with bone (186 g), burned rock (48,810 g),debitage (n=640), mussel shell (13 g), burned clay (1.3 g, listed as Other on Table 8-4), and lithic tools. Lithic tools from Level 6 included three Late Archaic projectile points, three bifaces, and one core. However, historic materials are present in small quantities,

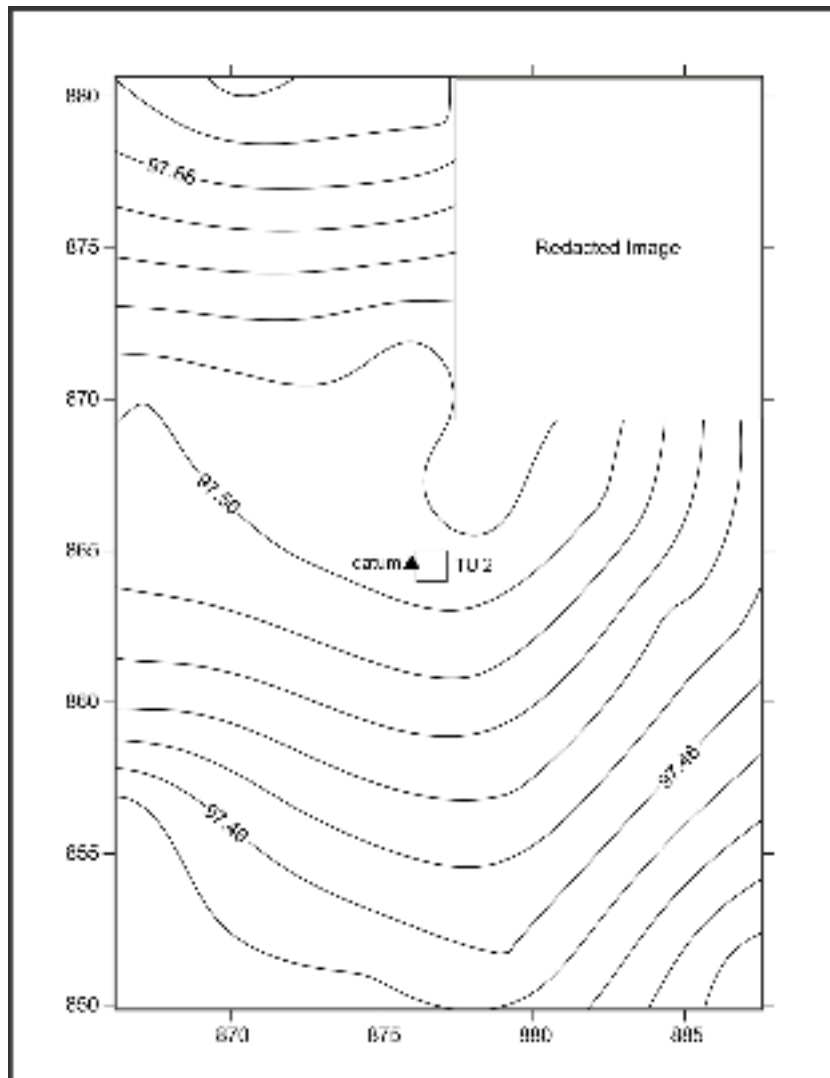

Figure 8-5. Test Unit 2 in Map 3 area. Inset shows area location on Figure 8-1.



Figure 8-6. Test Unit 2 in Map 3 area, looking south.

Table 8-3. Artifacts Recovered from Test Unit 2

Level	Faunal	Burned Rock	Native Ceramic	Debitage	Glass	Lithic Tools and Cores	Metal	Other	Total
1	2				36		2	1	41
2	15	4	1	11	36	1			68
3	25	68		287		2		1	383
4	11	24		75	3				113
5		11		12					23
6		1		12	1				14
7		4		2					6
8		1							2
9		1		5					6
10									0
11									0
Total	53	114	1	404	76	3	2	2	656

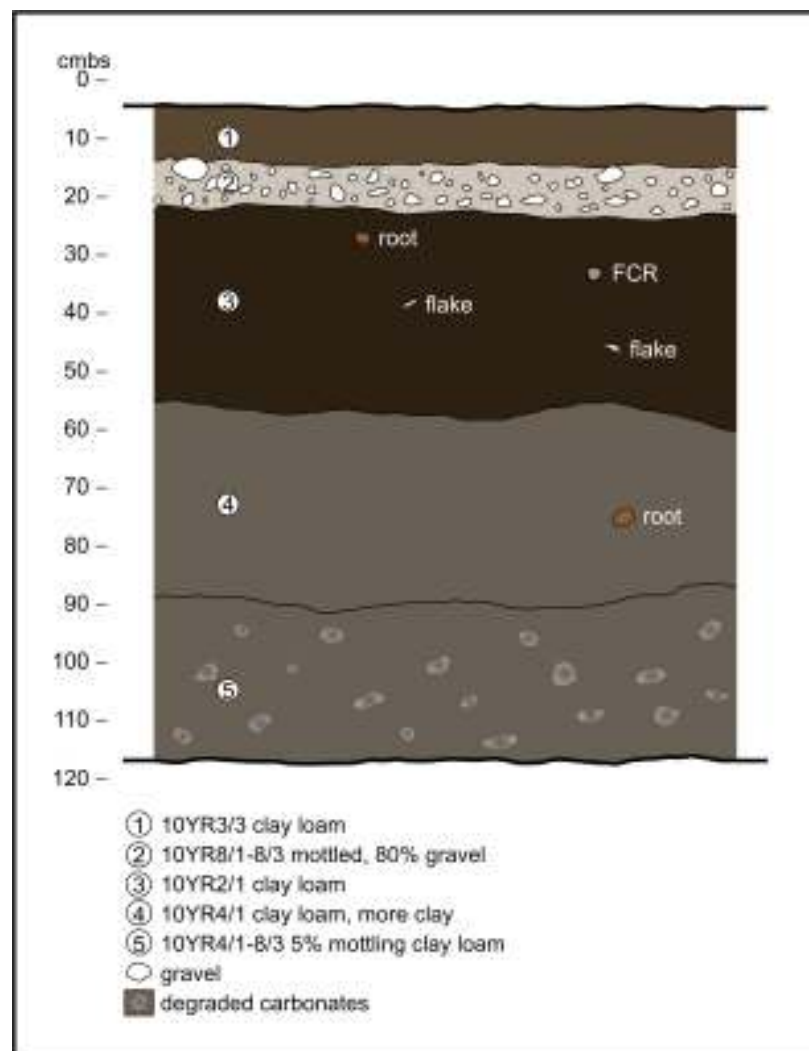
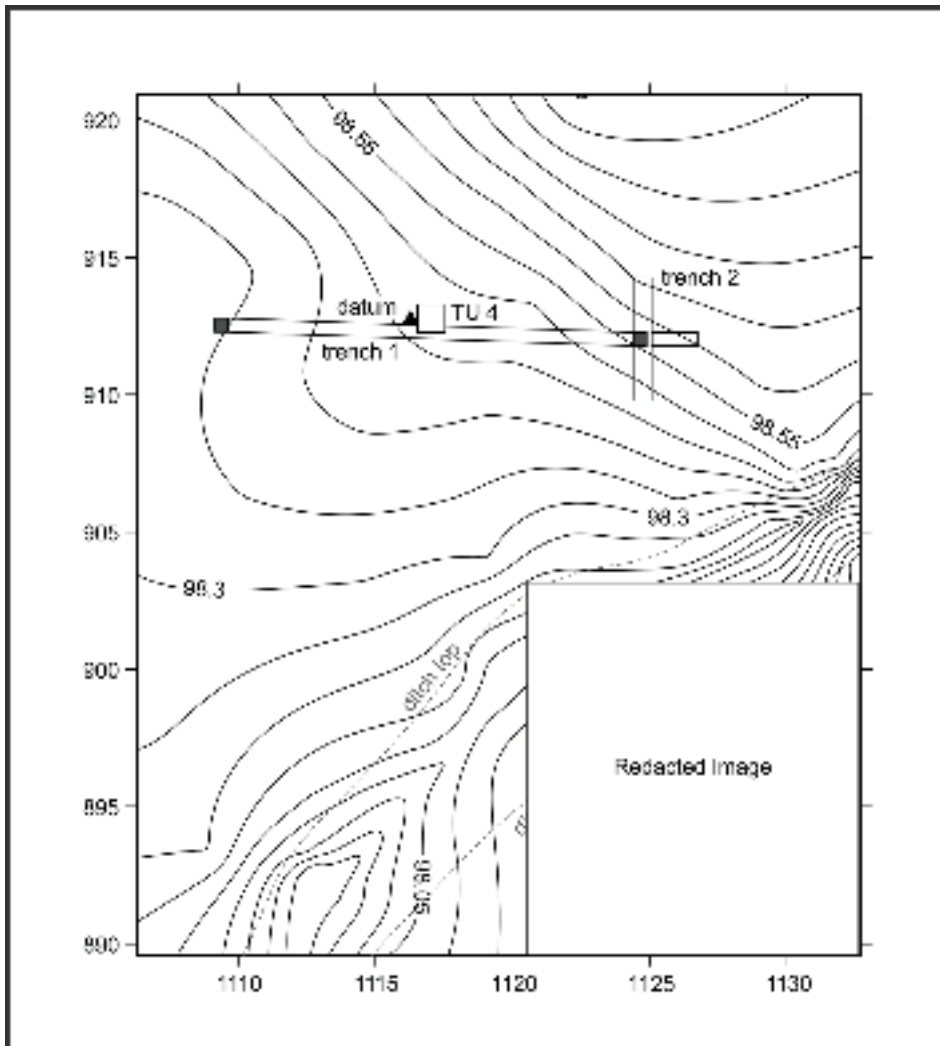

Figure 8-7. Profile of Test Unit 2.



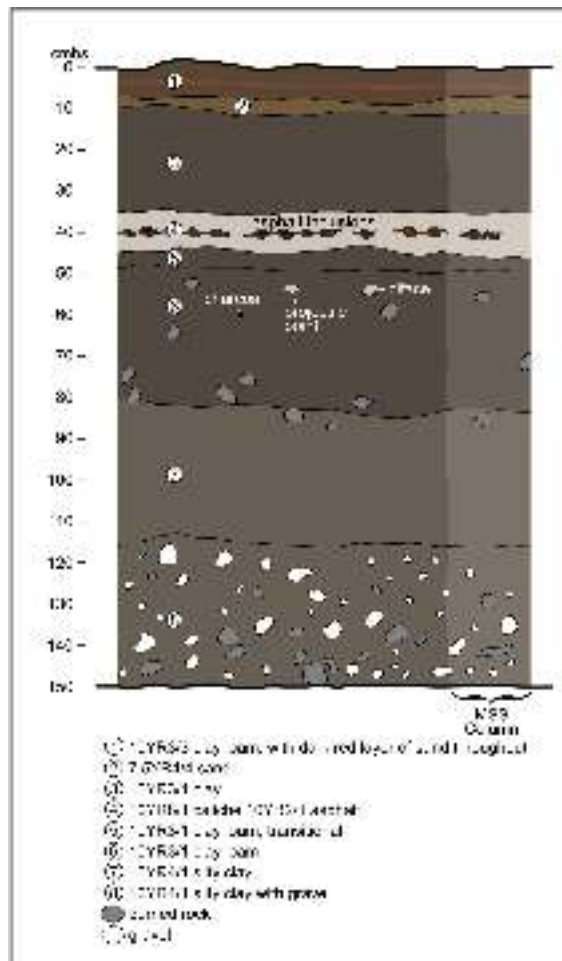

Figure 8-10. Profile of Test Unit 4, Map 4 area.

Table 8-4. Artifacts Recovered from Test Unit 4

Level	Bone	Burned Rock	Ceramics	Charcoal	Debitage	Glass	Building Material	Lithic Tools	Metal	Other	Total
1					6	5			4	2	17
2		5			14	24		1	3		47
3	1	7	1			1			2		12
4					3	4			3		10
5	6				47	8			3		64
6	273	264			640	2		7	2	2	1190
7	432	418			852	3		10		4	1719
8	352	441			1154		7	12		4	1970
9	140	179			386		8	11		1	725
10	63	82			210			1			356
11	39	82		1	270			2		4	398
12	8	85			198			1			292
13	1	124			117			7			249
14	4	232			107		1	1			345
15		70			52			2		1	125
Total	1319	1989	1	1	4056	47	16	55	17	18	7519

with glass (n=2) and metal (n=7) recorded. Level 7 contained many prehistoric artifacts that consisted of bone (432 g), burned rock (11,955 g), debitage (n=852), mussel shell (20.5 g), burned clay (2.2 g), ochre (1.7 g), and one bone bead (listed as Other on Table 8-4). There were ten lithic tools in Level 7 that included one Late Archaic projectile point, seven bifaces, one utilized flake, and one piece of ground stone. Level 8 contained an abundance of lithic material, including over 1,150 pieces of debitage, lithic tools (n=12), and burned rock (15,022 g).

Artifacts counts begin to decrease below Level 9, though several hundred items were consistently present until near the bottom of the excavation (see Table 8-4). A single radiocarbon date on a small piece of charcoal (Appendix A; Beta 390003) from Level 9 (100-110 cmbs) produced a corrected date of 670 +/- 30 RCYBP. Calibration with OxCal (Bronk Ramsey 2009) at two sigma yields date ranges of AD 1274 to 1320 (53.1% probability) and AD 1351 to 13,911 (42.3% probability). As discussed in more detail in Chapters 10 and 11, this unit had a number of Late Archaic projectile points from above and in Level 9, and magnetic susceptibility patterns suggest good integrity. This is further supported by patterns in carbonate accumulation that suggest low levels of post-depositional artifact movement. The Late Prehistoric data, then, is too recent given the associated artifacts and overall patterning. There is rodent disturbance in these deposits that probably accounts for the isolated recovery of 15 pieces of brick/tile in Levels 8 and 9, as well as a single piece in Level 14 (Table 8-4). Following the acquisition of the charcoal date, CAR staff attempted to date multiple pieces of bone from the lower levels of this unit. Being larger in size, bone is less likely than small pieces of charcoal to be displaced. However, CAR staff were unable to isolate collagen from these faunal remains.

The excavation for TU 4 was terminated at 170 cmbd. Two auger holes dug at the bottom of the unit to depths of 220-230 cmbd were negative for artifacts, suggesting that, while deeper deposits may be present below 150 cmbs, they are not dense.

The data in Table 8-4 combined with the stratigraphic information in Figures 8-8, 8-9, and 8-10 clearly suggests a high density and variety of material in the prehistoric deposits. The presence of brick fragments and the Late Prehistoric data suggest some mixing probably as a function of rodent activity in this deposit, starting in Level 8 and continuing into Level 13; however, artifacts have extensive carbonate accumulation, suggesting significant time depth and, for the most part, stability. Several point types and other lithic tools were recovered in Levels 6-13 that provide some chronological data. These include Castroville, Frio, Marcos,

and Montell forms, as well as a probable Guadalupe tool that suggests an Early Archaic time frame for Level 13. While these are discussed in more detail in a later chapter, the deposits began to accumulate during or before the Early Archaic and potentially continued into the Late Archaic. The abrupt start of the prehistoric material at Level 6, in combination with the profile data and field observations, clearly suggests that the end of the Late Archaic, potentially the Late Prehistoric, and Proto-historic/Colonial Period occupations, if present in this area, were removed. These upper levels are fill or relatively recent in origin. Nevertheless, the deposit appears to reflect artifact accumulation over roughly 4,000 years.

Following the excavations of TU 4, and given the density of the remains, two 50-x-50 cm units, designated TU 11 and TU 12, were excavated 7 m to the east and 7 m to the west of TU 4. The units were not screened but were simply shoveled out, down, and through the light colored, modern fill defined as caliche in Figure 8-10. These were initially designed to serve as platforms for auger bores, but the level of rock in the deposits made this impossible. Subsequently, a mini-excavator was used to cut a narrow (45-cm wide) trench connecting TUs 11 and 4. The trenching was designed to penetrate the top of the prehistoric deposit, confirming that the prehistoric deposit was present at a given location without cutting into and extensively damaging the deposits. Once below the caliche level, debitage, burned rock, bone, charcoal, and stone tools were encountered. The density of cultural material appeared to remain consistently high throughout the length of the trench. Accordingly, the trench was extended to the east to TU 12. As with the section of the trench to the west of TU 4, the eastern extension also produced artifacts below the caliche level. Backhoe Trench (BHT) 1 was just over 17 m in length. A second trench that cut across the first at the eastern edge of BHT 1 was excavated. Labeled BHT 2, this trench was excavated 2 m north and 2 m south of BHT 1 (Figures 8-11 and 8-12). The trench excavation was halted after a pipe was encountered.

The trenches show that the deposit encountered in TU 4 minimally extends 17-x-4 m. To explore this area further, a small section near the east end of BHT 1, near the intersection with BHT 2, was excavated down to 1.4 m below the surface (mbs) and widened to allow a profile of the deposits to be drawn. The profile, shown as Figure 8-13, demonstrates that the deposits sampled by TU 4 continue to at least 1.4 mbs in this location.

Map 5/Test Unit 13

TU 13 was placed in the softball field in the southeastern section of the park (Figure 8-14). The location was selected because many of the initial shovel tests in these fields were

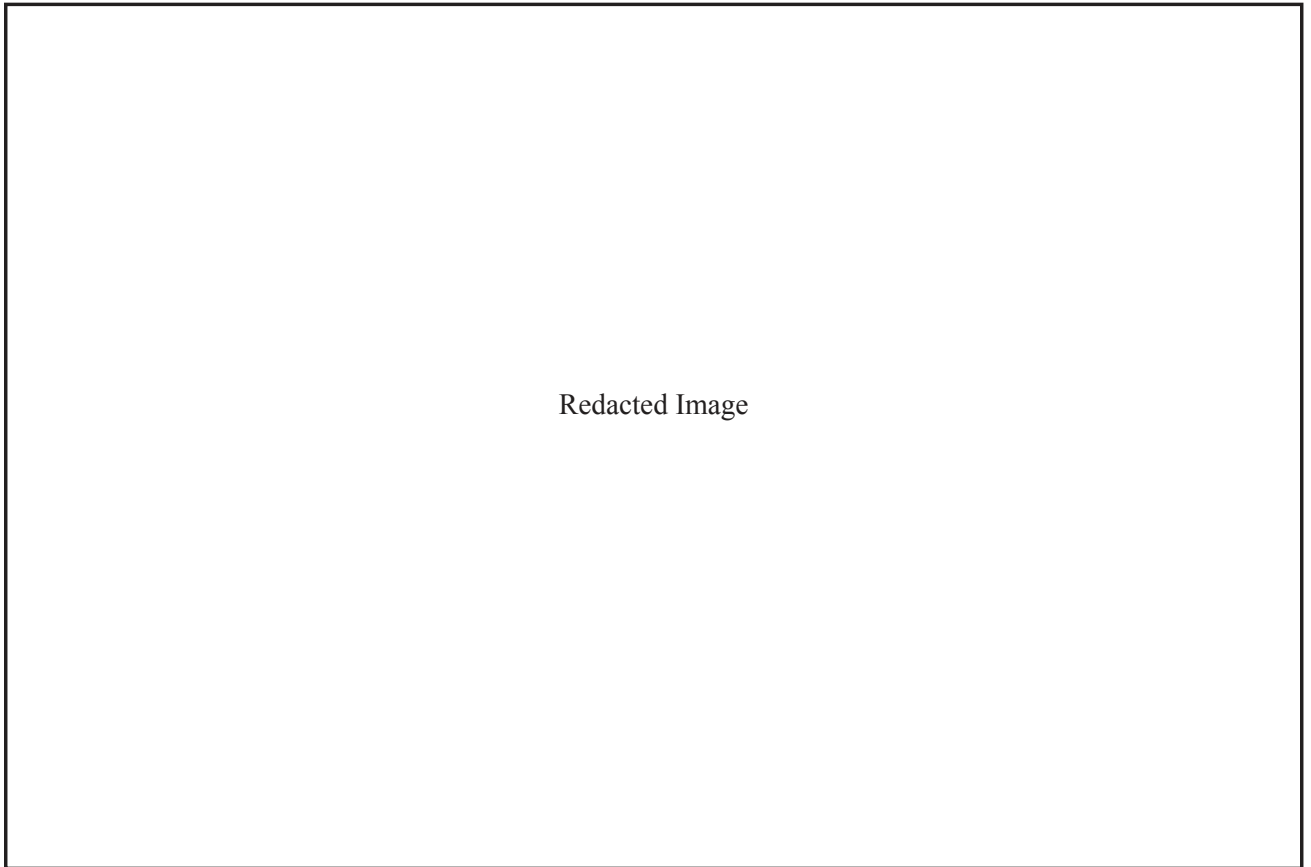

Figure 8-11. Backhoe trench in Map 4 area. Facing west. BHT 1 is at the center, with BHT 2 intersecting and running from left (south) to right (north). BHT 1 is partially backfilled in photo.

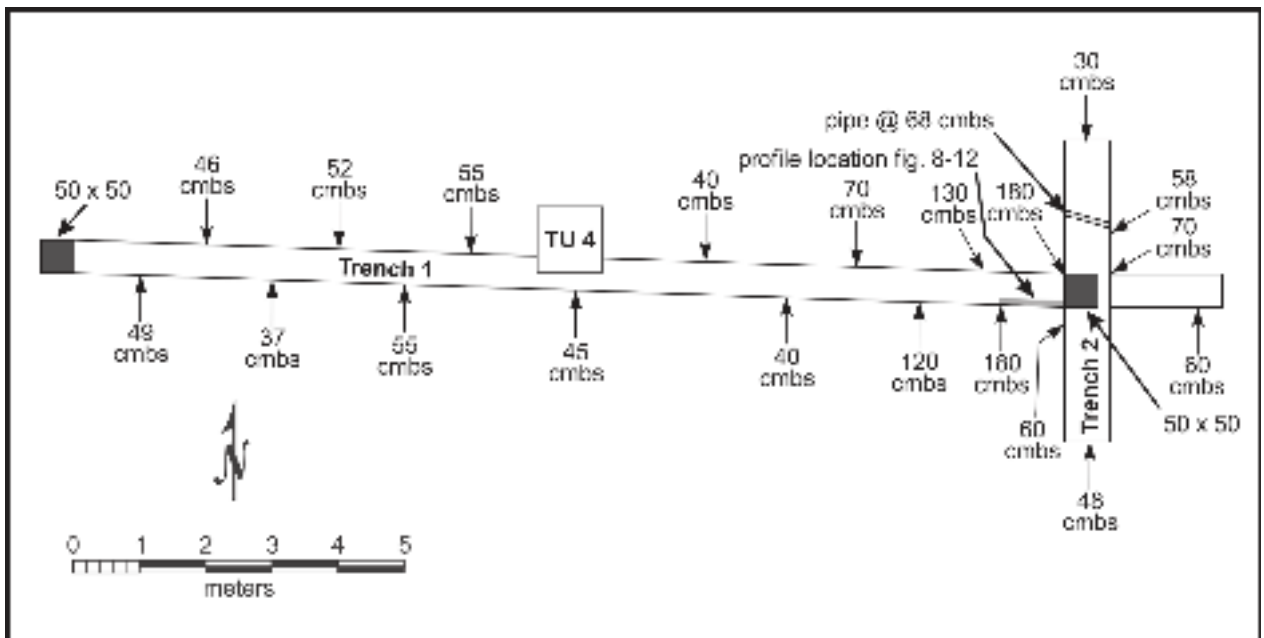

Figure 8-12. Plan view of excavations in Map 4 area showing TU 4 and backhoe trenches. Measurements (cmbs) record the depth of the trench.

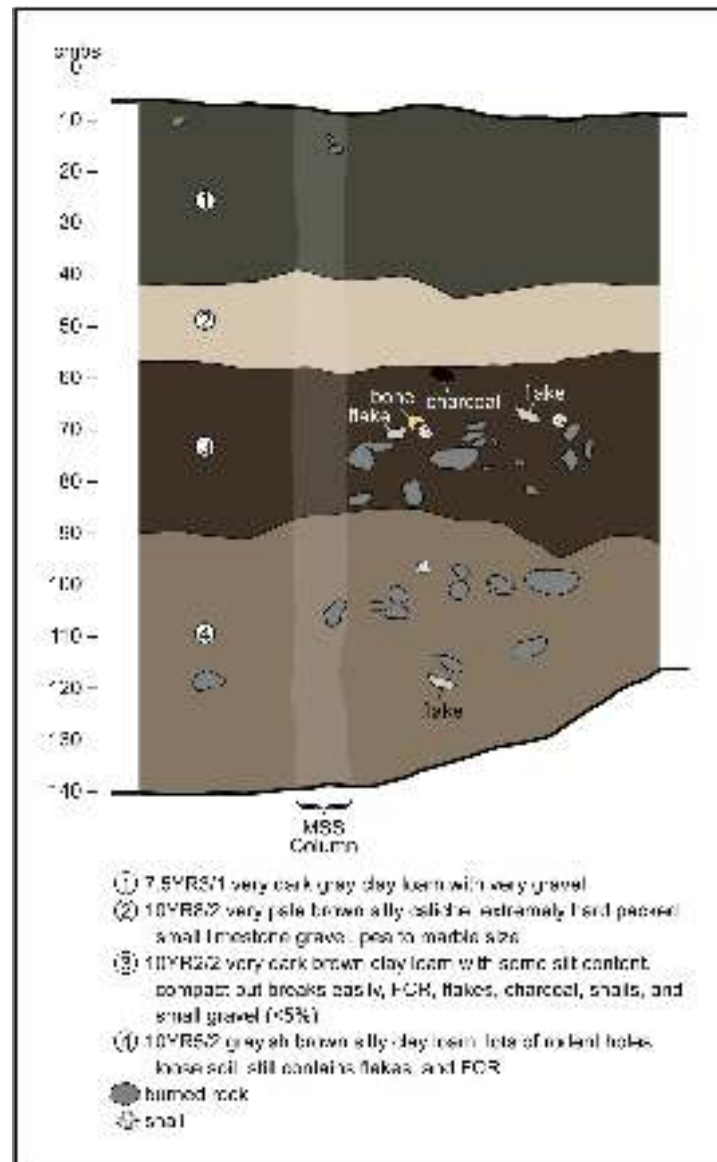

Figure 8-13. South profile of a section of BHT 1, near east end of trench. Note that the deposits continue below bottom of trench.

negative, and the deposits appeared to be disturbed. This pattern suggests the fields may have a layer of fill. Shovel tests were terminated at 60 cm, and they may not have penetrated below that fill layer. To explore these lower depths, TU 13 was excavated to a depth of 170 cmbd in 13 levels. The total amount of soil removed during excavation was 1.48 m³. Based on shovel testing, it was likely that the upper area consisted of fill with little data; therefore, the initial two levels were excavated in 20-cm units. From Level 3 (60 cmbd) to the top of Level 13, excavation levels were 10-cm thick. In Level 13, only a half of the unit was removed down to 170 cmbd. Augers holes were then excavated in the bottom of the level, with one going down to 220 cmbd. No artifacts or features were noted in the augers holes.

Figure 8-15 shows the three soil strata identified for TU 13. These consist of a brown (10YR 3/3) clay loam atop a black (10YR 2/1) clay loam with five percent gravels. The third strata of soil was described as a black clay loam. Note the high frequency of vertical cracking in these clay dominated sediments, especially in the middle and lower strata.

Table 8-5 presents the recovered artifacts. In comparing these totals, note the upper two levels are 20 cm in depth, and Level 13, though 10-cm in depth, is only a 1-x-0.5 m excavation. The data shows that there is a mixture of prehistoric and historic material, especially in the upper deposits. These artifact distributions are influenced by the tendency of clays in this section of the project area to develop cracks. The

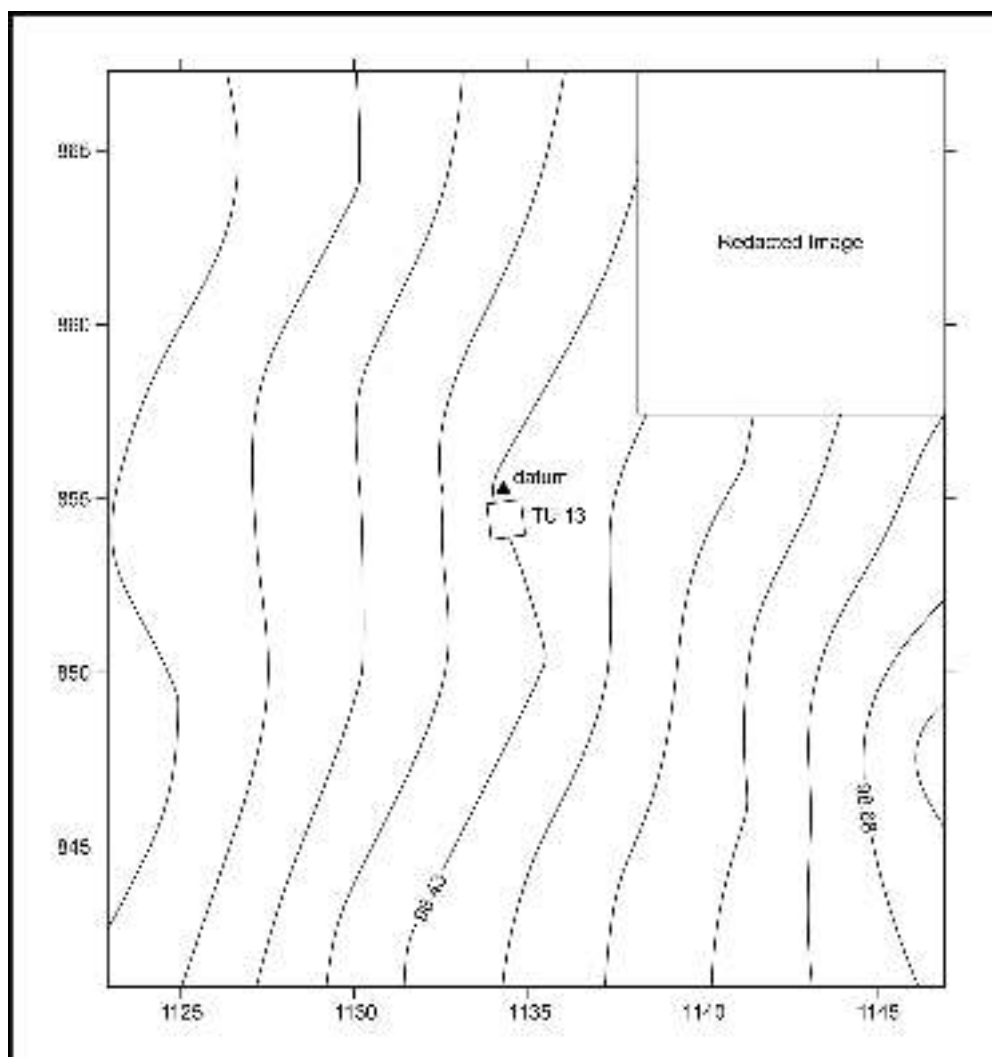

Figure 8-14. Test Unit 13 in Map 5 area. Inset shows location of area on Figure 8-1.



Figure 8-15. Photograph of Test Unit 13 in Map 5 area. Note vertical cracks.

Table 8-5. Artifacts Recovered from Test Unit 13

Level	Faunal	Historic	Prehistoric	Grand Total
1		1	9	10
2	3	107	57	167
3		20	49	69
4		14	39	53
5		1	93	94
6		1	70	71
7			87	87
8		1	42	43
9			91	91
10		2	52	54
11		3	64	67
12			31	31
13			15	15
Grand Total	3	150	699	852

excavators noted a high frequency of artifacts recovered in vertical position within the soil. However, 82% of the material did consist of prehistoric material. Historic material recovered from the unit consisted of glass (n=93), white earthenware ceramics (n=3), and a variety of metal (164 g), including cut and wire nails, and heavily rusted unidentified pieces. Prehistoric material included burned rock (2,629 g), Native American ceramics (n=3), debitage (n=414), and lithic tools (n=10).

Map 6/Test Units 1, 5, 6, and 10

The area depicted in Figure 8-16 as Map 6 includes TUs 1, 5, 6, and 10. Table 8-6 gives a total of the cultural material recovered from the test units, each of which is discussed below. There are four radiocarbon dates from this area, with three dates on bone collagen (CAR 345, 346, and 347) and a single date (Beta 390004) on charcoal (Appendix A). One date is from TU 1, and three are from TU 5. Each of these dates is discussed below with the associated unit.

In TU 1, 1.5 m³ of soil was removed in 15 levels. The excavation in this unit was terminated at a depth of 170 cmbd (150 cmb). Table 8-6 shows a high frequency of historic/modern material in this unit relative to other units in this area. Much of this material was in the upper five excavation levels. This material includes one piece of unidentified ceramic, metal (164 g), glass (n=15), and other materials that included asphalt (n=8) and brick (n=2). Figure 8-17 shows a profile of the east wall of TU 1. As noted in the profile, the upper 15 cm (Layer 1) consisted of disturbed soil above a roughly 20-cm

thick layer of limestone dominated fill, probably reflecting an old road base (Layer 2, Figure 8-17). Layer 3 was a dark grayish brown (10YR 4/2) hard silty clay that stretched into excavation Level 4 (30-40 cmb). Layer 4 soil was a very dark grayish brown (10YR3/2) loam with a high frequency of snail, debitage, and charcoal. The other major feature visible in the profile is a large wooden post. Layer 5 was a light brownish gray (10YR 6/2) silty loam with disturbance from rodents and roots. The deepest strata, Layer 6, consisted of a grayish brown (10YR 5/2) silt.

Figure 8-18 shows the distribution of the non-prehistoric material by level in TU 1. The bimodal distribution evident in the upper levels is probably a function of low density associated with the limestone fill that dominated Level 3. Materials from above Level 3 include several aluminum pull tabs, chunks of asphalt, and a 2002 U.S. dime. Materials from below Level 3 have a different composition, with a wide variety of glass, much of which has patina noted as present, rusted cut nails, and a ceramic fragment that may represent an insulator. Some of the deeper material is related to the wooden post, driven into the ground some time before the limestone fill/road base layer was added. The 1899 Trueheart Map (Figure 8-2) shows that the fence line of the zoo cut through this area, directly over TU 1, and the buried post could reflect that fence line.

A small amount of prehistoric material is present in the upper four levels of TU 1, including burned rock (n=1), chipped stone debitage (n=22), and bone (n=2). The presence of prehistoric material increased significantly in Levels 5-15 of

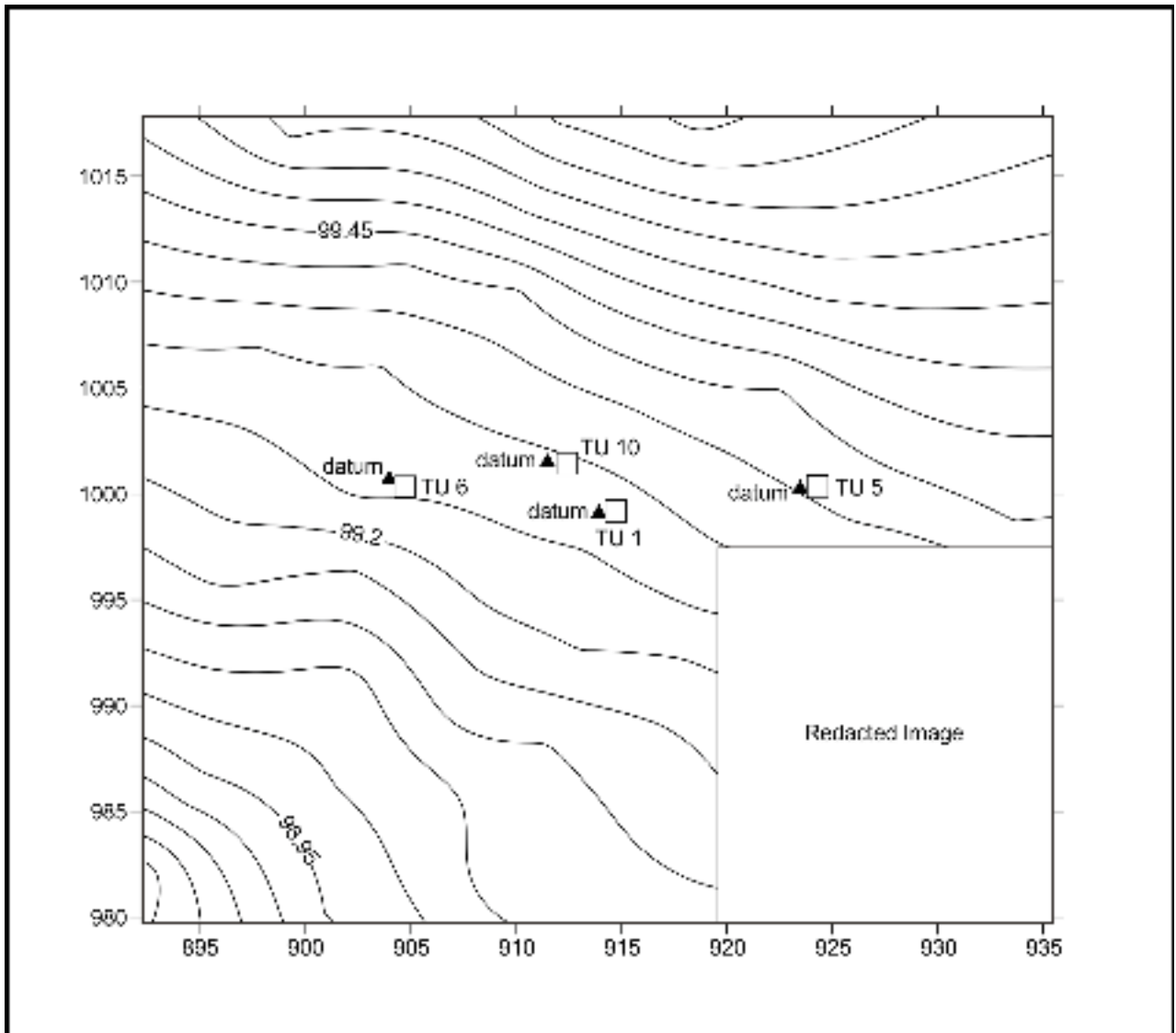

Figure 8-16. Map 6 showing location of Test Units 1, 5, 6, and 10. Inset shows location of area on Figure 8-1.

TU 1. Material from these levels included bone (69.7 g), burned rock (70,885 g), mussel shell fragments (7.6 g), debitage (n=939), and a variety of lithic tools, including two edge-modified flakes, one biface, a ground stone fragment, a Late Prehistoric Perdiz point in Level 5, and a Late Archaic dart point, possibly a Lang (Turner and Hester 1999:141-142), recovered in Level 6. A single collagen radiocarbon date (CAR 347; Appendix A) from a large mammal bone from Level 5 produced a corrected date of 1848 +/- 26 RCYBP. When calibrated with OxCal (Bronk Ramsey 2009), the probable two-sigma date range is AD 86 to 236 (95.4% probability). The Late Archaic date is earlier than the associated Late Prehistoric Perdiz point but in line with the underlying Lang dart point date range.

Much of the material from the lower levels of TU 1 is attributed to Feature 1. Feature 1 may be a discrete feature or it may be part of a sheet midden, and it was encountered in Level 8 (Figure 8-19). The feature appears to be at the bottom of Layer 4, just as it transitions into Layer 5 (Figure 8-17). It was defined by a cluster of larger rock within the unit outlined in Figure 8-19. The feature was not clearly defined in the eastern profile (Figure 8-17). Cultural material recovered from Feature 1 consisted of bone (10.7 g), debitage (n=386), burned rock (59,462 g), charcoal (3.7 g), mussel shell (0.9 g), snail shell (19.6 g), and lithic tools that included an edge-modified flake, two bifaces, and a possible piece of ground stone.

Artifacts decreased in the unit at 110-120 cmbd. There was some disturbance in the southeast corner of the unit due

Table 8-6. Artifacts Recovered from Map Area 6

Test Unit	Bone	Burned Rock	Historic/Modern	Debitage	Lithic Tools	Mussel Shell	Total
1	144	1159	61	963	9	13	2349
5	314	264	35	601	8	26	1248
6	26	359	25	756	9	3	1178
10	138	453	38	845	18	39	1531
Total	622	2235	159	3165	44	81	6306

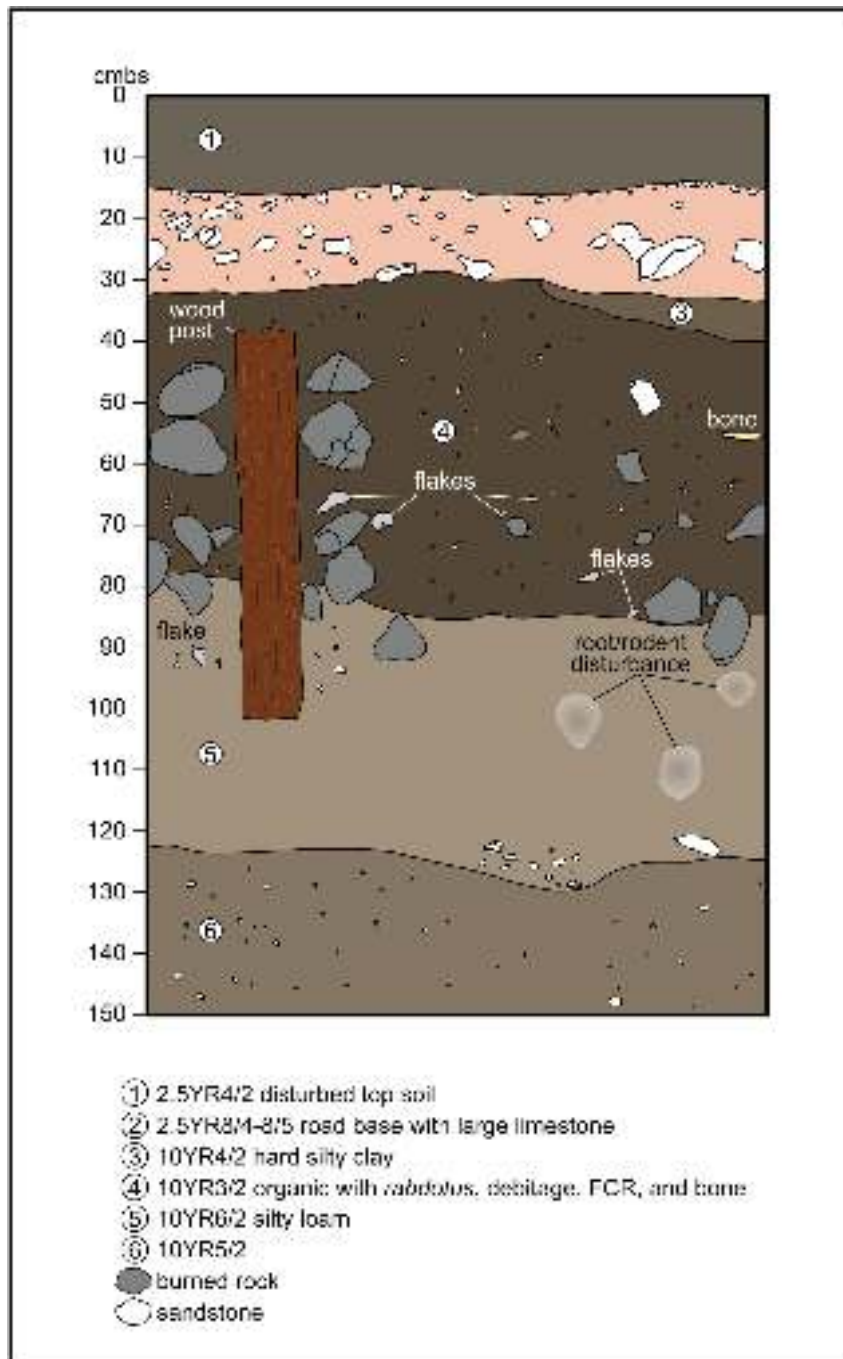

Figure 8-17. Profile drawing of east wall of Test Unit 1.

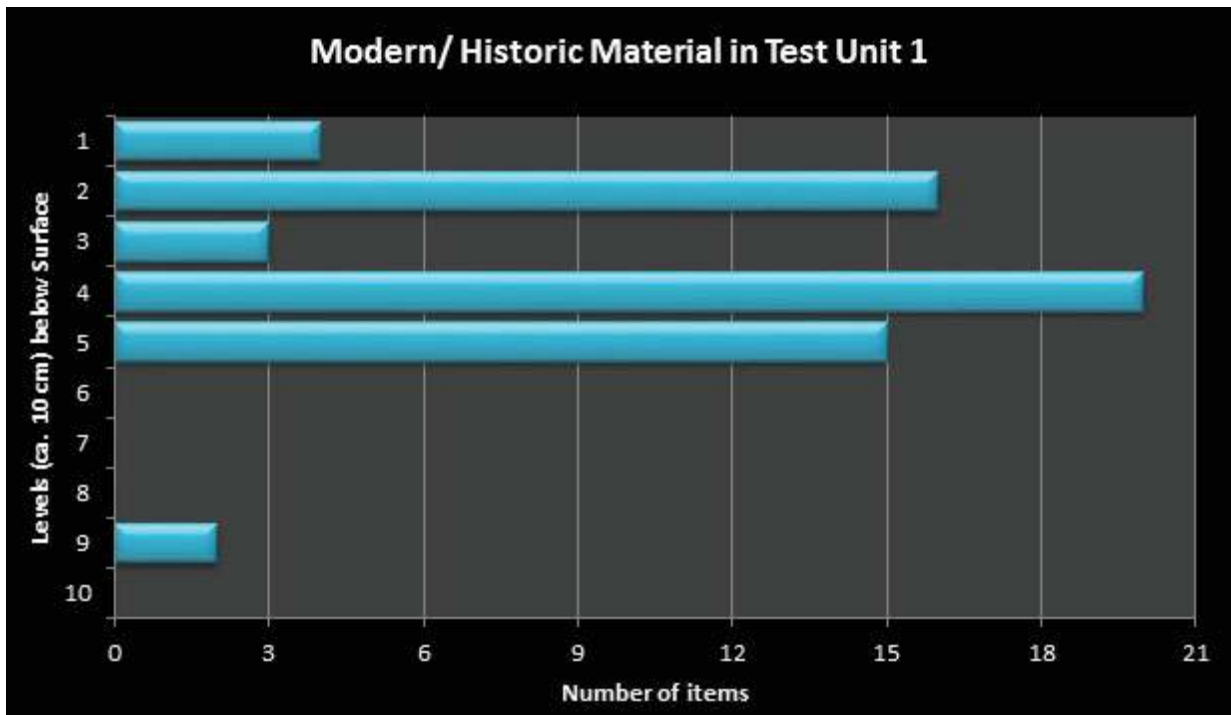

Figure 8-18. Distribution of modern/historic material in Test Unit 1.

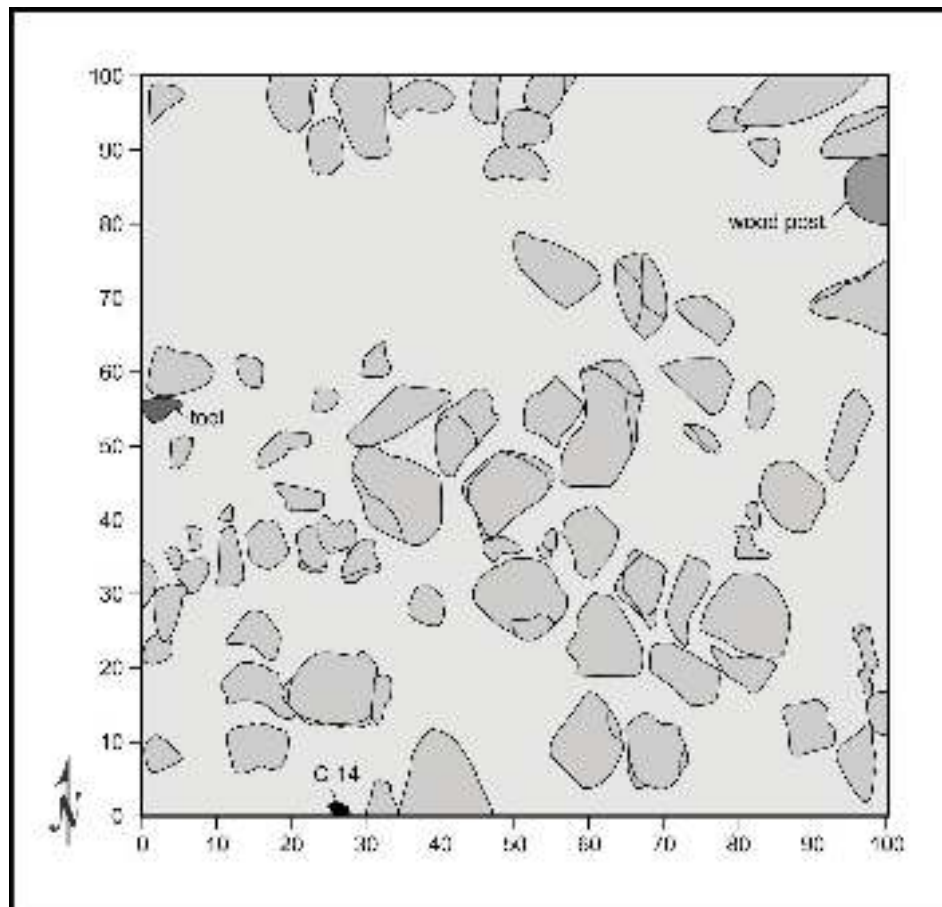

Figure 8-19. Feature 1 in Test Unit 1, Level 8.

to rodent activity (see Figure 8-17). Auger Hole 1 was excavated at the bottom of TU 1 to a depth of 210 cmbd. Soil from the auger hole consisted of a brown (10YR 5/3) silt with gravel inclusions. No artifacts were found during the auger excavation.

TU 5 was also located in the Map 1 area (Figure 8-16). The amount of soil removed from this test unit was 0.98 m³. Three soil types were encountered during excavation of TU 5. The first two layers were disturbed with heavy gravel associated with road base. Underneath the modern strata was black silty clay. Figure 8-20 is a photograph of the east wall of TU 5 that shows the clean breaks between the strata, with a concentration of recent limestone capping the underlying clay and silt deposit.

Excavations for TU 5 terminated at 10 levels (120 cmbd) as the primary interest was to trace out the rock distribution initially encountered in this area of TU 1. The distribution of artifacts in TU 5, like that in TU 1, was influenced by the limestone-dominated, sterile, fill layer clearly visible in Figure 8-20. The initial level of this unit produced nine artifacts, including debitage (n=1), burned rock (n=1), glass (n=4), plastic (n=1), and pieces of stoneware ceramic (n=2) that probably are from a sewer pipe. The second excavated

level yielded one rusted metal object of unknown function. There was no recovery in Level 3, which was entirely within the limestone-dominated fill. Level 4, which transitioned from the limestone-dominated fill into the underlying dark brown sandy/silty clay contained only two items (debitage and a cut nail). Artifact recovery increased significantly in Level 5. While small amounts of glass (n=6) and metal (n=12), including a mixture of heavily rusted wire (n= 6), and cut (n=5) nails, were present, bone (16.2 g), debitage (n=54), burned rock (1500 g), mussel shell (0.1 g), and one biface were also recovered. The majority of material from Levels 6-10 were prehistoric, with the exception of cut nails in Levels 7 (n=1), 9 (n=1), and 10 (n=1), and a piece of unidentified metal in Level 8. Prehistoric material in Levels 6-10 included bone (113.5 g), debitage (n=544), burned rock (13,034 g), charcoal (2 g), mussel shell (5.8 g), and one Native American ceramic recovered from Level 10. Seven lithic tools/cores were also found in these levels.

Three radiocarbon dates were acquired from this unit (Appendix A). A radiocarbon date on charcoal from Level 9 was obtained from Beta analytic (390004). The corrected date of 980 +/- 30 RCYBP calibrates in OxCal (Bronk Ramsey 2009) to AD 993 to 1058 (46.1% probability) and AD 1075- to 1155 (49.3% probability) at a two-sigma range. The



Figure 8-20. Photograph of the east wall of Test Unit 5.

Austin Interval Late Prehistoric date is above the small (0.9 g) Native American ceramic in Level 10. The results from TU 1, the depth of these items in TU 5, and the presence of nails in Levels 9 and 10 suggest both the ceramic and the charcoal are probably not in good stratigraphic context. However, as the ceramic and the date are both within the Late Prehistoric, it is at least conceivable that some of the material above Levels 9 and 10 are more recent in age, possibly reflecting proto-historic or colonial material. Two additional dates were submitted to explore that possibility (Appendix A).

CAR 346 was a bone collagen sample from a very large mammal, in the size range of bison or cow, from Level 6. CAR 345 was a bone collagen sample from a large mammal, in the size range of a deer, and came from Level 8. The Level 6 sample returned a corrected date of 155 +/- 23 RCYBP, with multiple calibrated age ranges using OxCal and two-sigma. The sample could potentially be modern in age, dating sometime after AD 1915. However, it is more likely that the sample dates to from AD 1720 to 1785 (38.5% probability), with an AD 1666 to 1700 date having a probability of 16%. While these date ranges are certainly consistent with the notion that some of this upper deposit reflects a proto-historic or colonial deposit, CAR radiocarbon sample 345 from Level 8 returned a corrected date of 1905 +/- 22 RYCBP (Appendix

A), with an OxCal calibrated range of AD 50 to 137 (94.2% probability). This Late Archaic date is above both the Late Prehistoric charcoal date and the Native American ceramic. Clearly, then, some of these deposits are mixed. However, it is also clear that some of these deposits likely date to the Proto-historic and/or Colonial Period.

TU 6, also in the Map 6 area (Figure 8-16), was excavated to a depth of 120 cmbd. Roughly, 0.96 m³ of soil was removed and screened from the excavation of this unit. Figure 8-21 is a photograph of the north wall of the TU 6. Like both TUs 1 and 5 from this same area, recent fill dominated the upper five levels. From the surface down to 70 cm, which was near the base of the large limestone rocks, glass (n=16), concrete (n=1), and plastic (n=2), along with a small amount of debitage (n=7) and burned rock (0.7 g) were recovered. Levels 6 and 7, below the fill, consisted of a very dark grayish brown (10YR 3/2) clay or silty clay that contained high densities of prehistoric material. Bone (8.1 g), charcoal (1.2 g), burned rock (10,715 g), debitage (n=607), mussel shell (4.2 g), and lithic tools (n=7) were recovered. The tools included two cores, one projectile point, two bifaces, one edge-modified flake, and one uniface. The projectile point is consistent with a Late Archaic Castroville form (Turner and Hester 1999:86-88). There were, however, small amounts



Figure 8-21. Photograph of the north wall of Test Unit 6.

of historic material, with a single piece of amber colored container glass and several pieces of metal (25.1 g) including an aluminum pull tab. The lowest two levels had a dramatic decrease in artifacts, with Levels 8-10 containing bone (0.9 g), burned rock (722.7 g), charcoal (0.1 g), debitage (n=142), and one projectile point. The projectile point was consistent with a Middle Archaic La Jita form (Turner and Hester 1999:140), though that characterization is tentative.

TU 10 was the last unit excavated in Map 6 area (Figure 8-16). This unit was excavated to a depth of 80 cmbd in 10-cm levels, with the removal of 0.77 m³ of soil. Five soil strata were identified in this unit. As with other excavations in this area, the first two levels consisted of silty clay loam atop a compact area of limestone and sand that may be a road base. Below the compact base deposit was a silty clay loam that ranged in color from a very dark grayish brown to brown (Figure 8-22). Table 8-7 presents the artifacts recovered from TU 10 according to depth. Modern/historic and prehistoric material were present in Levels 1-4, though the upper three levels, to 30 cmbs, had only three pieces

of debitage and a single burned rock. Other material in the upper three levels included plastic buttons, various types of container glass, rusted metal, and a 1917 U. S. penny. Level 4 was a transitional level with eight pieces of clear and olive colored container glass, several cut nails, other rusted metal, and coal slag, along with a significant increase in debitage (n=79), burned rock (1769 g), bone (77.8 g), and lithic tools and cores (n=7). Included in the lithic tools was a single Late Prehistoric Perdiz projectile point (Turner and Hester 1999:227-228). Totals for this level also included a single Native American sherd.

The remainder of the unit (see Table 8-7) contained only prehistoric material. Bone (53.1 g), burned rock (19,990 g), debitage (n=762), lithic tools (n=11), mussel shell (15.7 g), and one piece of burned clay (0.7 g) were recovered. A second Native American sherd was recovered from Level 5. In addition, Table 8-7 shows there is evidence in the prehistoric artifacts and faunal counts for a lower (80-90 cmbd; 60-70 cmbs) peak in materials.



Figure 8-22. Photograph of Test Unit 10, looking north.

Table 8-7. Artifacts Recovered from Test Unit 10

Depth (cmbd)	Faunal	Historic	Organic	Prehistoric	Grand Total
20-30		3		3	6
30-40				1	1
40-50		11		1	12
50-60	56	16	6	138	216
60-70	9			178	187
70-80	41			208	249
80-90	73		1	611	685
90-100	9			178	187
Grand Total	188	30	7	1318	1543

Summary

The testing described above presents a consistent pattern of disturbance in the upper 30-50 cm for most areas within the park. This clearly reflects the history of disturbance outlined in Chapter 4, with much of it probably related to the 1899 work or more recent renovations. The compact, white to gray, consistent deposit of carbonate and gravel that abruptly appears and terminates in several of the photos and profiles, often identified as caliche, as well as frequent references to road base consisting of crushed limestone and sand, certainly reflects some form of fill deposit. In most areas with deposits below 40-50 cm, the distribution of artifacts also shifts below that level. High-density peaks are reflected in several of the tables at various depths. These are generally dominated by prehistoric material. The single exception to this pattern of a clearly delineated, compact, and generally sterile level is in TU 13, located in the area of the softball fields. Here, the profile and photographs show the deposits are dominated by a blocky clay, with a high frequency of vertical cracking. The artifact pattern in TU 13 is more dispersed as well, with

the artifact peaks represented in other areas lacking in this unit. The pattern is consistent with the shovel testing data in this area discussed in the previous chapter, which reflected a low density of artifacts, with no concentration, and a high frequency of modern material. One possibility is that sediments in this area have been transported into this section of the park.

Testing results suggest that this type of sediment movement is common across the site. While there are likely to be several areas with intact deposits deep, the upper 30-40 cm across much of the park is probably disturbed, with artifacts lacking context. That disturbance level appears to be well defined by a sterile, compact layer of recent fill in most areas tests. As discussed in Chapter 11, this pattern is consistent with magnetic susceptibility values that suggest the upper deposits in many areas have been removed, re-deposited, or otherwise truncated. Again, this is consistent with accounts of park history. However, the testing results also have identified several areas that have potential for intact deposits, including two areas with some potential to contain proto-historic and colonial material.

Chapter 9: Project Activities-Searching for the San Pedro Colonial Dam and *Acequia*

Raymond Mauldin, Antonia Figueroa, and Kristi Nichols

The testing results in the previous chapter, as well as the shovel test information discussed in Chapter 7, and the Chapter 4 discussion of park history all suggest that the upper 30-40 cm across much of the park is disturbed. One of the goals of the investigation was to identify proto-historic and colonial deposits, including a search for evidence of the San Pedro *Acequia* in the region and the associated colonial dam, both constructed in the early eighteenth century. The levels of disturbance outlined previously suggest that proto-historic and colonial material may have been extensively impacted as this would have been closest to the surface at the time of renovations. There are no artifacts that can be attributed

unequivocally to the Proto-historic or Colonial Period. However, there are two radiocarbon dates on bone that have a moderate-to-high probability of reflecting occupation in the late seventeenth or early eighteenth century, and there is extensive archival information on the use of San Pedro Park during that period. The efforts to locate two specific features mentioned in the archival documents, the San Pedro dam and associated *Acequia*, are presented in this chapter.

The focus of this chapter is on the Map 7 area (Figure 9-1). Previous investigations in this area reported by Houk (1999), which included shovel testing and trenching, concluded that

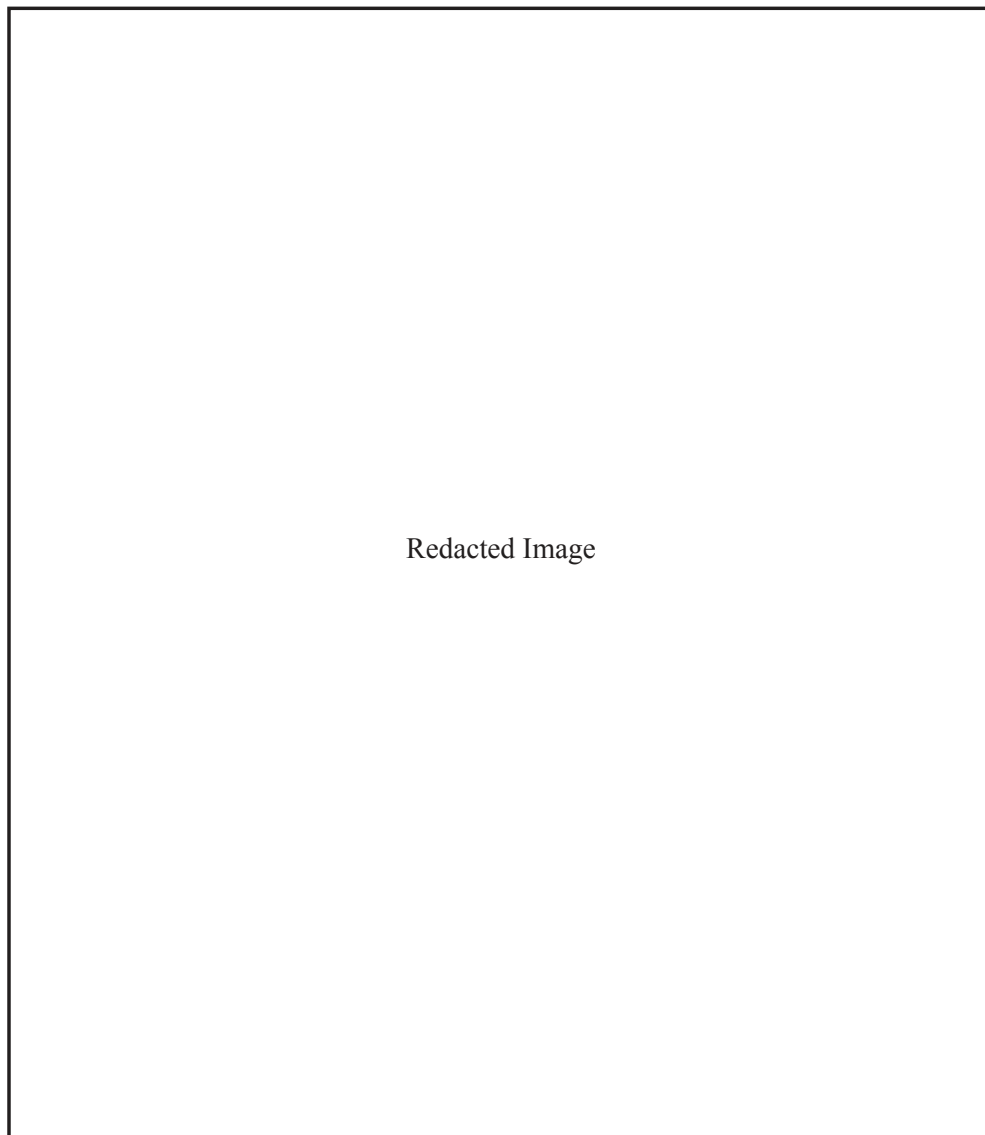

Figure 9-1. *San Pedro Park, with Map 7 area identified.*

the area immediately to the south of the pool was disturbed. Houk suggests that the colonial head gate and upper sections of the *acequia* were destroyed by earlier construction, and that the dam most likely was beneath the sidewalk area, just to the south of the current swimming pool (Houk 1999:22). Shovel testing results for the current project area are consistent with that assessment. ST 46, excavated roughly 6 m to the south of the pool sidewalk and terminated at 60 cmbs, had disturbance throughout, with high frequencies of gravel present near the surface, and modern material noted in as deep as 60 cm.

While it is likely that the dam and associated deposits in the immediate area are disturbed, there is some probability that portions of the *acequia* itself are present within the park. Prior to initiating excavations in this area, CAR staff reviewed archival sources as well as maps and files stored at CAR in an attempt to better define the location of these

features. This review produced three historic maps that had a pre-1900 plotting of the location of the San Pedro *Acequia* and sufficient detail to allow for a reasonable overlay onto modern park maps. These were the 1860 Friesleben Map (Figure 9-2), the 1870 City Engineer Map (Figure 9-3), and the 1899 Trueheart Map (Figure 9-4).

The earliest of these three maps, the 1860 Friesleben Map, had the least amount of information available for alignment with the modern park maps. Orientation and general size were obtained from blocks and streets, and several slightly different placements are consistent with available landmarks. Nevertheless, Figure 9-2 shows the probable start of the *acequia* and likely gate area just under the northwest corner of a building. The path of the *acequia* is east of the main sidewalk, eventually exiting the park at the gate area. It is shown as a straight ditch separated from the creek by 10-20 m of land.



Figure 9-2. San Pedro Park, 1860 Friesleben Map, overlaid on modern park aerial photograph.

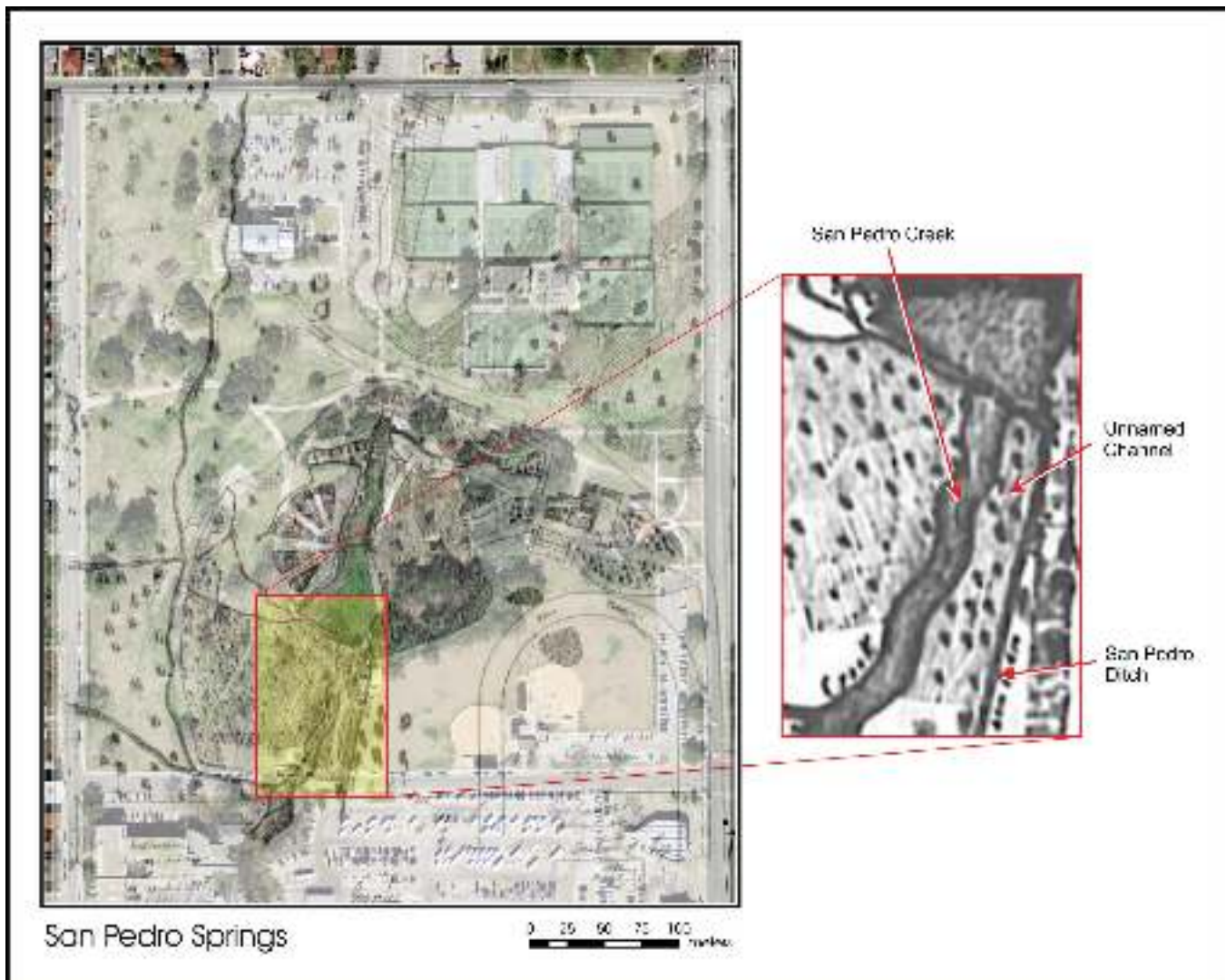

Figure 9-3. *San Pedro Park, City Engineer Map, C. Hartmill (from Cox 1999:9), August of 1870 overlaid on modern park aerial. Inset shows the southern section of the original map with the possible unnamed third trail or channel identified.*

The second map consulted, the 1870 City Engineer Map drawn by C. Hartmill (Figure 9-3), provides more mapping points, but it is also more difficult to interpret because of the poorer quality of the available image. This map places all features, including the dam (not shown on the 1860 map), the head gate, and the *acequia* slightly to the east. The overlay, like that of the 1860 map, shows the “San Pedro Ditch” as a straight canal located slightly farther to the east. As shown in the blow-up of the original, this map has three areas depicted, the creek, the ditch, and a sinuous path centered between the two. The path is not labeled, and while it could represent a foot trail or a swale, it begins at the head gate. This third path or channel was not shown in the more general 1860 map.

The final map reviewed is the 1899 Trueheart Map (Figure 9-4), and it is by far the most detailed, with the *Alazán Acequia*, the Grotto, and several other common features available for accurate comparison. This map overlay has the highest probability of providing an accurate location, at least as the features appeared in 1899. This plotting suggests the dam is located at the end of the modern pool, placing it north of the sidewalk. The head gate for the ditch is located under the corner of a modern building. The 1899 map shows the creek as more constricted than the earlier maps, and only a single channel is depicted. Note, however, that the channel shape is similar to the shape of the middle, unnamed trail or channel on the 1870 map rather than the straight “San Pedro Ditch” (Figure 9-3, inset).

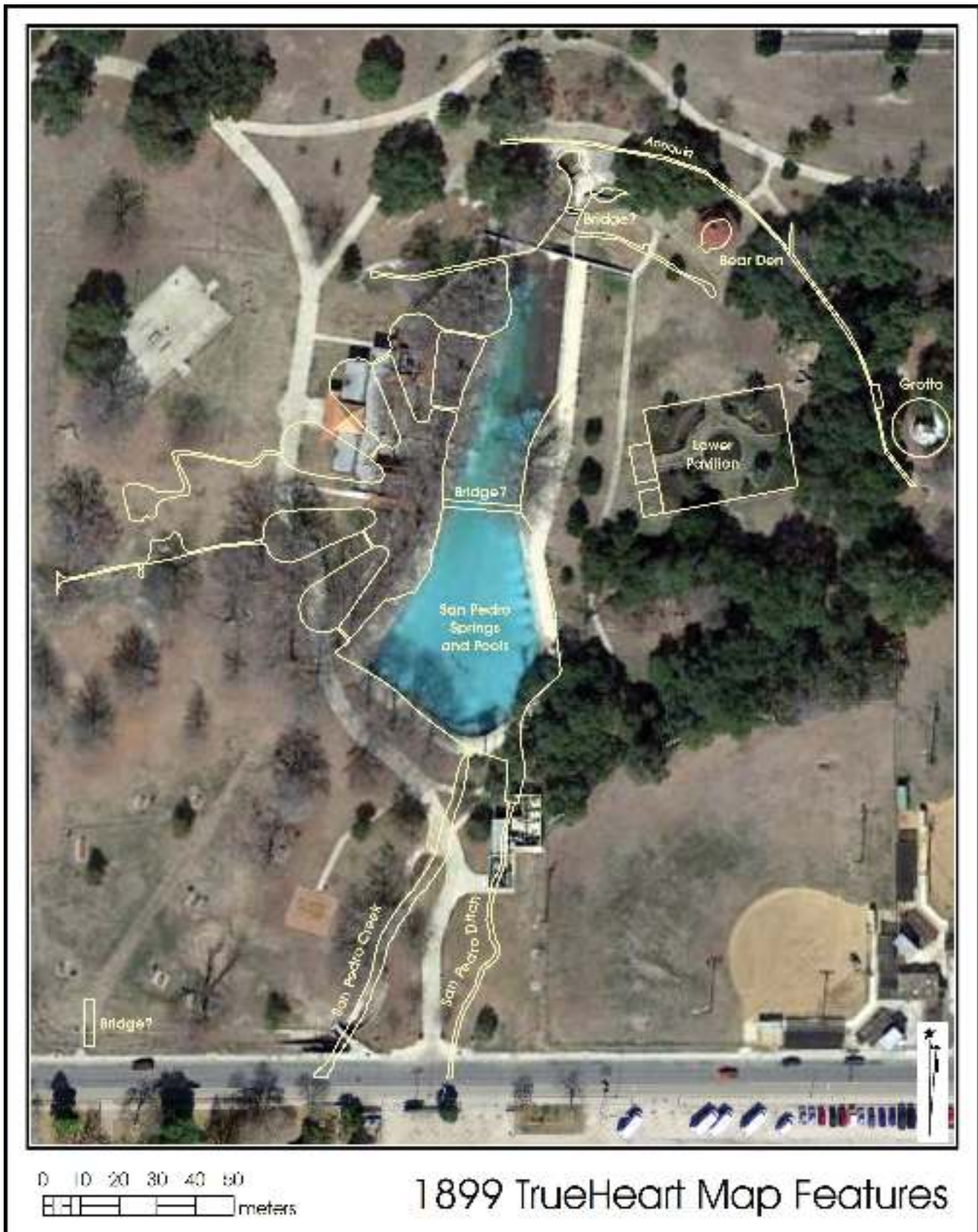

Figure 9-4. San Pedro Park, 1899 Trueheart Map overlaid on modern park aerial.

Based on these overlays, previous testing, and shovel tests, it is unlikely that any evidence of the colonial dam or head gate remain. The overlays do suggest that in addition to San Pedro Creek there could be remnants of one, or possibly two, channels exiting the park to the south. The overlays indicate that the most likely place to encounter evidence of those channels is to the east or under the modern sidewalk. CAR had originally proposed to test to the east with backhoe trenches; however, a series of water and electrical lines run through this area. Figure 9-5 shows the sidewalk (left) with spray-paint highlighting the location of some utilities. Additional utilities associated with the swimming pool, phone, and water are shown in Figure 9-6. Discussions with park maintenance personnel suggest that there is a high potential for additional, unmarked lines in this area.

No suitable locations existed for backhoe trenching that would intersect these channels to the east of the sidewalk; therefore, CAR staff opted for a location to the west of the sidewalk and excavated areas by hand. The location to the west of the sidewalk was not ideal, but it was the closest place

for excavation without the potential for major impacts to the infrastructure of the park. Figure 9-7 shows the location of these two units, identified at TUs 8 and 9.

Map 7/Test Units 8 and 9

TUs 8 and 9 were excavated west of a sidewalk on the southern end of the park (Figure 9-7). In effect, these represented a 1-x-2 m excavation area. TU 8 was excavated to a depth of 170 cmbd, and 1.42 m³ of soil was removed. TU 9 reached a depth of 160 cmbd with the removal of 1.25 m³ of soil (Figure 9-8). Soils from the two test units were described as a clay that ranged from a dark grayish brown (10YR 4/2) silty clay to a yellowish brown (10YR 5/6) silty clay with 50-70% gravel. Beneath the silty clay layers was a black (10YR 2/1) clay followed by two layers of a very dark gray (10YR 3/1) with 80-100% gravel.

Table 9-1 presents the artifact counts from TUs 8 and 9. There was extensive disturbance in both units, and this is clear from the mixture of prehistoric and historic material



Figure 9-5. Utility lines identified by red paint to the east of the southern sidewalk exit.



Figure 9-6. Additional utility lines associated with area of acequia. Building in top and bottom photos is visible in Figure 9-5 to right.

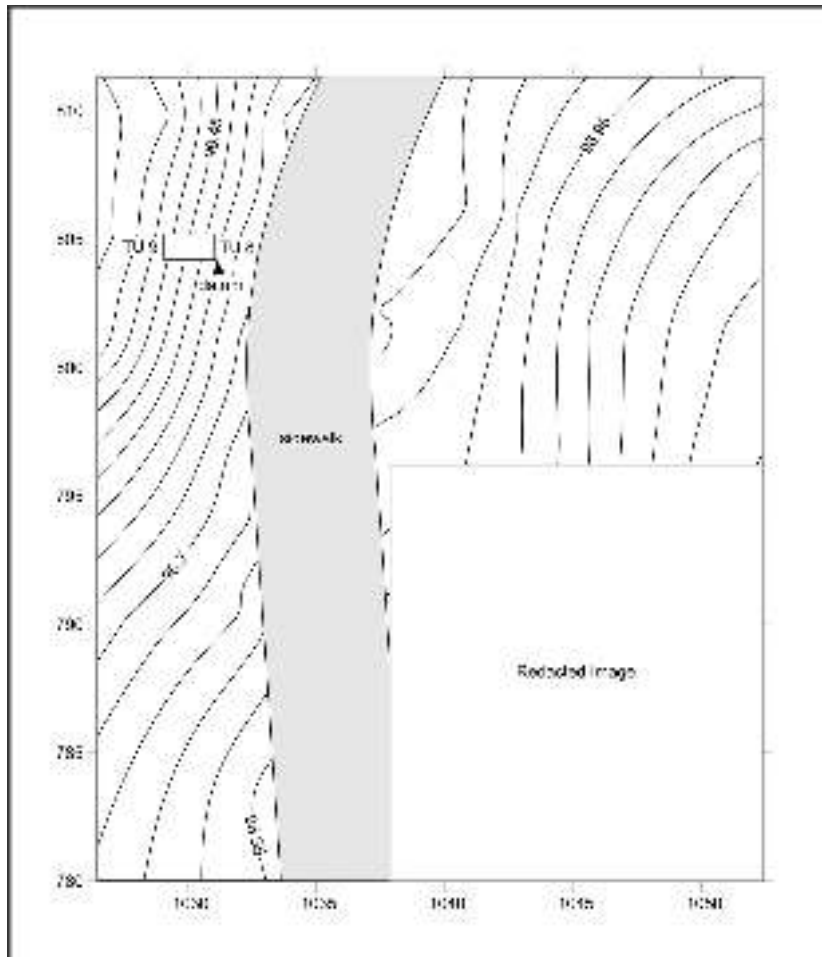

Figure 9-7. Locations for Test Units 8 and 9, Map 7 area.



Figure 9-8. Test Units 8 and 9. Note gravel fill in floor on east, in east wall, and in north wall of Test Unit 8. Sidewalk is roughly 1.5 m to the east.

Table 9-1. Artifacts Recovered from Test Units 8 and 9

Levels	Faunal	Historic	Modern	Prehistoric	Grand Total
1	1		1		2
2	5	7		1	13
3		4			4
4		4		2	6
5		4		6	10
6	2	41	3	11	57
7		4		15	19
8	1	19		7	27
9	1	22		7	30
10	1	30	2	5	38
11	1	90	2	19	112
12	6	57		6	69
13	2	8		1	11
Grand Total	20	290	7	80	398

throughout the levels. Historic material made up 73% of the material recovered from the unit and included glass (n=35), ceramics (n=84), construction material (n=4), and metal (821 g). Prehistoric artifacts included burned rock (1746.9 g), debitage (n=34), and lithic tools (n=10). Note the high density of historic artifacts at lower depths.

Figure 9-8 is a photograph of both units following excavation. Visible is the lower section of the north wall, the floor, and sections of the east and west walls of the two units. TU 8, located farthest to the east, clearly had a channel first encountered at the bottom of Level 4. The channel was filled with 70-95% gravel, and it cut across the unit from the northwest to the southeast. On the bottom of TU 8, the gravel is confined to the far eastern side of the floor and continues downward. Note that the gravel is fill material, characterized by consistent size and pieces that are angular rather than rounded as might be associated with a fluvial deposit. Given the location, it seems unlikely that this trench is related to the *acequia*, as the *acequia* should be several meters to the east. Clearly, the area was a ditch that was subsequently filled with

gravel, and at least one sand bag, to level the area. This may reflect another channel or it may be related to the construction of the sidewalk itself.

Summary

Based on a review of previous research, archival maps, overlays, and a single shovel test, CAR suggests that the original colonial dam and head gate associated with the San Pedro *Acequia* is likely to have been destroyed by previous construction. Because of concerns with damaging utilities and park infrastructure, excavations in this area of the park were limited and not ideally located. Test excavations, consisting of two 1-x-1 m units, did uncover a channel, though the location is not consistent with that of the San Pedro *Acequia* as depicted on most maps. This location may, in fact, be the possible channel shown in the 1870 City Engineer Map (Figure 9-3, inset) of some other excavation associated with the construction. While additional archival work may clarify the nature of activities in this section of the park, further excavation might be the only way to resolve these issues.

Chapter 10: Artifacts Recovered

Antonia Figueroa, Sarah Wigley, Raymond Mauldin, Melissa Eiring, Clint McKenzie, and Barbara Meissner

The shovel testing (Chapter 7), test units based on the shovel tests (Chapter 8), and the excavation of TUs 8 and 9 to investigate the possible location of the San Pedro *Acequia* (Chapter 9) produced a wide variety of artifacts. This chapter provides a short summary of each of the major classes of material and specifically discusses general characteristics for metal, glass, ceramics, vertebrate fauna, chipped stone, and burned rock recovered on the project. The primary concern, however, is on the vertical distribution of different classes of material, their distribution, and characteristics that might have chronological importance.

Metal Objects

A variety of metal objects were recovered on the project. Five hundred and sixty five (n=565) pieces weighing just over 2 kg were collected. Items included beer can fragments, aluminum pull tabs, bottle caps, bottle openers, a spark plug, wire nails, cut nails, bullet casings, wire, a metal button, a 1917 U. S. penny, a 1959 U. S. nickel, a 2002 U. S. dime, other metal items, and a large quantity of unidentified metal fragments and pieces. Most of this material was recovered in test units, though shovel and auger tests recovered about 25% of the material by count.

Test units produced 421 pieces of metal weighing 1.647 kg, with most recovered from within 50 cm of the surface. Figure 10-1 presents the distribution for metal within TUs 1-7 and TU 10. Each bar is the average weight recovered for a given level. The weights have been corrected for the volume of excavated sediment in each level. In addition, no metal was recovered at depths below 100 cm in these eight units.

TU 13, not included in the Figure 10-1 graph, had a similar distribution, with just over 161 grams of metal present in the upper meter. However, this unit also had small amounts of metal between 110-120 cmbs. The distribution of metal objects in TUs 8 and 9 is radically different from that depicted in Figure 10-1. In this area, which almost certainly represents some type of filling event, roughly 84% of the 821 grams of metal are from below 100 cm. There is also a high frequency of cut nails, wire nails, bolts, and unidentified metal scraps. By count, these make up 159 of the 166 items, or 96%, of the material recovered. For all other areas, these types of materials still dominate, but they make up roughly 87% of the 255 items. Note that these two units account for roughly half of all metal collected by weight and 39% of the metal by count.

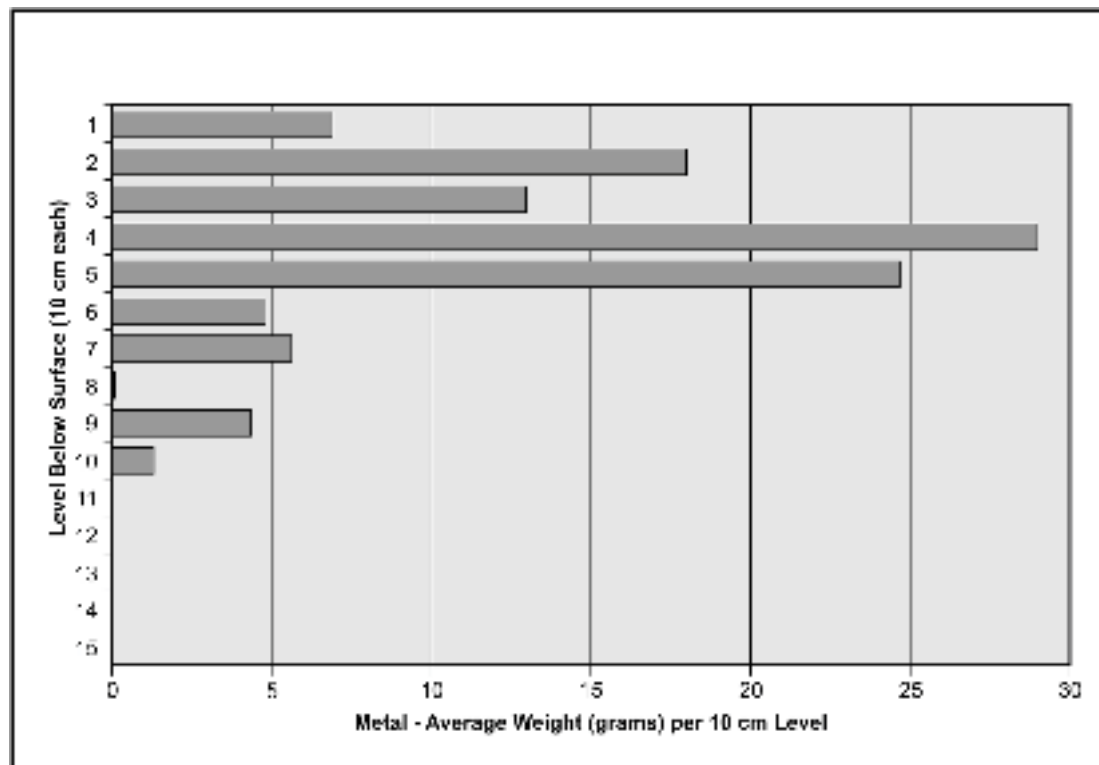

Figure 10-1. *Metal weight (grams) from Test Units 1, 2, 3, 4, 5, 6, 7, and 10 by level.*

Figure 10-2 shows a variety of metal objects recovered during testing, including a bullet casing, the 1917 U.S. penny recovered from TU 10 at 20-30 cmbs, two examples of carbon or brass rods, and a metal button with a shell inlay. The button was recovered in an auger test in the bottom of TU 12, a 50-x-50 cm unit near TU 4. The item appears to be a three-piece button, with the center section made of freshwater mussel pearl. The outer rim of the piece appears to be brass. This type of shirt collar or waistcoat button was common in the 1840 to 1860 period (S. Nesmith, personal communication to K. Hindes, 2014). The TUs 4 and 12 area is located just to the south of the Formal Gardens. Previously, this was the location of the Lower Pavilion, though this was probably not constructed until after the 1850s.

Glass

Not surprisingly, a large amount of glass ($n=746$, 1.685 kg) was recovered within the park. Most of this, or 1.639 kg, represents some type of container (Figure 10-3). Container glass colors were dominated by amber, brown, aqua, green, and olive, but clear glass containers were also present. The remaining glass (46 g) was classified as flat, chimney, or window glass, as well as other glass, which included two blue marbles.

About 30% of all glass recovered was from shovel tests, and 53 different shovel tests had glass present. Within the shovel



Figure 10-2. Selected metal objects, including 1917 U.S. penny and 1850s metal button.



Figure 10-3. Selected container glass items from San Pedro Park testing.

tests, glass was recovered from all levels. While the upper 30 cm contained the majority of the recovered glass within the shovel tests (61.5%), several STs had large quantities of glass at deeper levels, including ST 105 near the tennis courts, ST 46 outside the southern end of the swimming pool, and ST 93 near the western edge of the park.

Figure 10-4 presents the distribution of glass by level from TUs 1, 2, 3, 4, 5, 6, 7, and 10. Glass is concentrated slightly higher up in the profile than metal (see Figure 10-2), with most of the material concentrated in Levels 1-4. Glass is also more restricted, with few pieces recovered below 50 cm in these units (Figure 10-4). Several pieces of glass were recorded as heavily patinated, including samples from TUs 4 and 7.

The distribution of glass in TU 13, in the softball outfield, was radically different that of TUs 1-7 and 10. In the upper 20 cm of the excavation, only 0.5 grams of glass were recovered. Recall that, as discussed in Chapter 8, the initial excavations levels in TU 13 were 20 cm in thickness rather than 10 cm. Consequently, the density of glass in the upper levels of TU 13 averaged only 0.025 grams per level, much lower than the 14.3 and 19.8 grams in Levels 1 and 2 above (Figure 10-4). From 20-40 cmbs, however, 308.2 grams of glass was recovered in TU 13, an average of 154.1 grams per 10-cm level. This is substantially higher than the 18.2 and

12.3 gram averages for the other eight units summarized in Figure 10-4. A similar pattern is present from 40-50 cmbs, with the recovery of 32.6 grams in TU 13. Glass is also found deeper in TU 13, with the 140-150 cmbs level containing 3.4 grams. Most of the glass in this unit is container glass. The overall pattern is suggestive of high glass inputs, coupled with vertical displacement in the high clay soils in TU 13. As noted previously, these sediments had a high frequency of vertical cracks (see Figure 8-15). TU 13, of course, is in the outfield of an actively used softball field. Given the nature of field use, it is likely that glass and other material deposited on the surface of the outfield is removed quickly, accounting for the low initial recovery.

Finally, note that the other two units, TUs 8 and 9 in the Map 7 area, have moderate glass density (206 g, 17 levels) and a widespread vertical distribution, with fragments present from the initial level down to Level 11. This was similar to that seen previously for the metal artifacts, though the glass was not recovered from the bottom of these units.

Ceramics

CAR staff recovered 146 pieces of ceramic, weighing roughly 832 grams, from shovel testing and test unit excavations at San Pedro Park. Twenty-three individual sherds were from shovel testing, with most of these (n=15) being in the upper

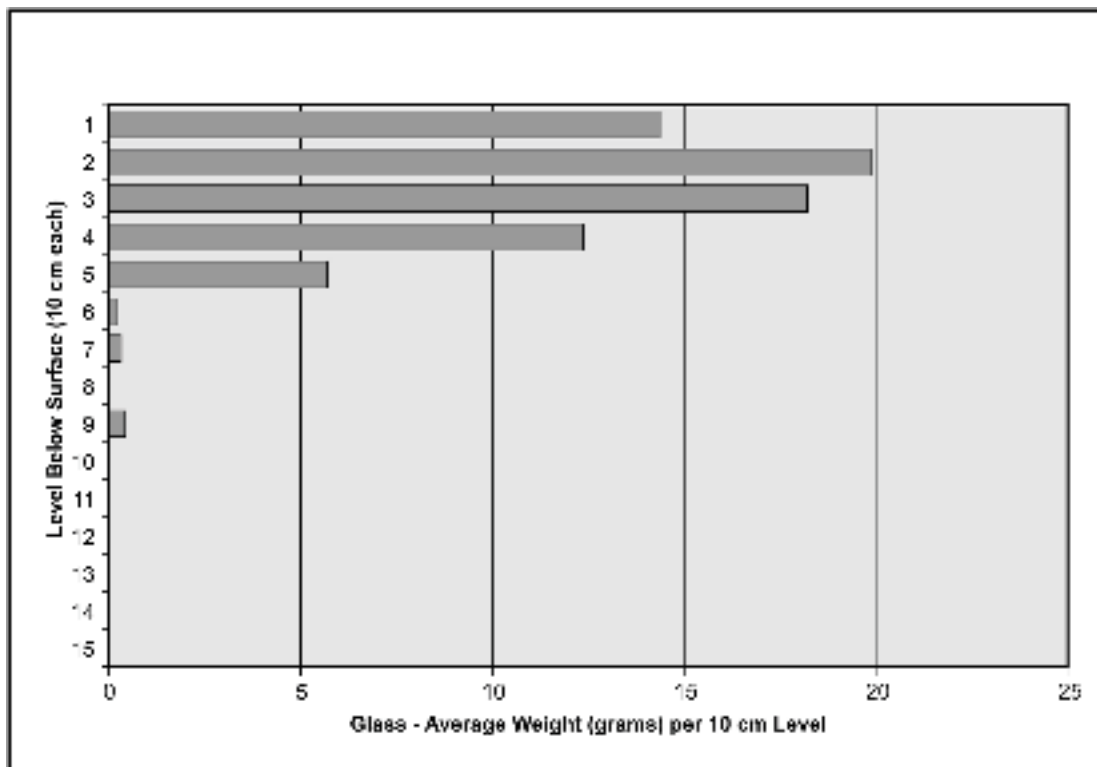

Figure 10-4. Glass weight (grams) from Test Units 1, 2, 3, 4, 5, 6, 7, and 10 by level.

30 cm of the deposits. The major types included white earthenware (n=12) and stoneware (n=9). A single piece of what may be flow blue was recovered from Level 6 of ST 39, located in the softball field. This could date from as early as 1825 (Yakubik 1990). The identification is tentative as the item is less than ¼-inch in maximum dimension and weighs less than 0.1 grams.

Test excavations produced 123 sherds weighing 595 grams. Removing items that were clearly modern (e.g., sewer pipe fragments), most of which were recovered from TUs 8 and 9 as well as several pieces from TU 7, left 103 items. Table 10-1 presents a summary of these materials, and examples of

several types are provided in Figure 10-5. The most common type in the table is an unidentified, thin terracotta ceramic. These accounted for 76 of the 103 remaining items. All 76 are from TUs 8 and 9, the units that formed a 1-x-2 m excavation at the south end of the park (see Chapter 9), and all were recovered between Levels 9 and 13. Given the context, it is possible that these are recent.

There are seven pieces of Native American ceramics (Figure 10-5), and all are bone tempered. Tentatively, some have been identified as prehistoric Leon Plain, though they are also consistent with Goliad. Their distribution has been discussed in Chapter 8. Material was recovered from the upper deposits

Table 10-1. Ceramics Recovered from Test Excavations

Unit/Level	Number	Type	Form(s)	Period
Unit 8 Level 10	14	Thin Terracotta	Unknown	Unknown
Unit 8 Level 11	7	Thin Terracotta	Unknown	Unknown
Unit 8 Level 12	2	Thin Terracotta	Unknown	Unknown
Unit 9 Level 10	3	Thin Terracotta	Unknown	Unknown
Unit 9 Level 11	39	Thin Terracotta	Unknown	Unknown
Unit 9 Level 12	8	Thin Terracotta	Unknown	Unknown
Unit 9 Level 13	1	Thin Terracotta	Unknown	Unknown
Unit 9 Level 9	2	Thin Terracotta	Unknown	Unknown
Unit 10 Level 4	1	Untyped Native Ceramic	Unknown	Late Prehistoric (possibly)
Unit 10 Level 5	1	Possibly Leon Plain/Untyped	Unknown	Late Prehistoric (possibly)
Unit 13 Level 10	1	Possibly Leon Plain/Untyped	Unknown	Late Prehistoric (possibly)
Unit 13 Level 2	1	Possibly Leon Plain/Untyped	Unknown	Late Prehistoric (possibly)
Unit 13 Level 2	1	Untyped Burnished Native Ceramic	Bowl	Late Prehistoric (possibly)
Unit 2 Level 2	1	Possibly Leon Plain/Untyped-Burnished	Unknown	Late Prehistoric (possibly)
Unit 5 Level 10	1	Untyped Native Ceramic	Unknown	Late Prehistoric (possibly)
Unit 8 Level 10	1	Undecorated White Ware	Chamber Pot	Mid - Late 19th Century
Unit 8 Level 12	1	Stoneware - Gin Jug	Jug	Mid - Late 19th Century
Unit 9 Level 11	1	Undecorated White Ware	Handle	Mid - Late 19th Century
Unit 9 Level 7	1	Stoneware with Hard Alkaline Glaze	Jug	Mid - Late 19th Century
Unit 1 Level 5	1	Red Paste with Brown Glaze Earthenware	Insulator (possibly)	Late 19th - Mid 20th Century
Unit 13 Level 2	2	White Earthenware with Yellow Glaze	Unknown	Late 19th - Mid 20th Century
Unit 13 Level 2	1	Undecorated White Ware Scalloped Edge	Bowl	Late 19th - Mid 20th Century
Unit 3 Level 2	1	Undecorated White Ware	Unknown	Late 19th - Mid 20th Century
Unit 3 Level 2	1	Porcelain Insulator	Insulator	Late 19th - Mid 20th Century
Unit 4 Level 3	1	Undecorated White Ware	Unknown	Late 19th - Mid 20th Century
Unit 7 Level 3	2	Undecorated White Ware	Unknown	Late 19th - Mid 20th Century
Unit 7 Level 4	1	Yellow Ware	Unknown	Late 19th - Mid 20th Century
Unit 7 Level 4	3	Undecorated White Ware	Unknown	Late 19th - Mid 20th Century
Unit 7 Level 4	1	Semi-porcelain Undecorated White Ware	Unknown	Late 19th - Mid 20th Century
Unit 7 Level 4	1	Decalcomania Decorated White Ware	Unknown	Late 19th - Mid 20th Century
Unit 8 Level 9	1	Undecorated White Ware	Unknown	Late 19th - Mid 20th Century

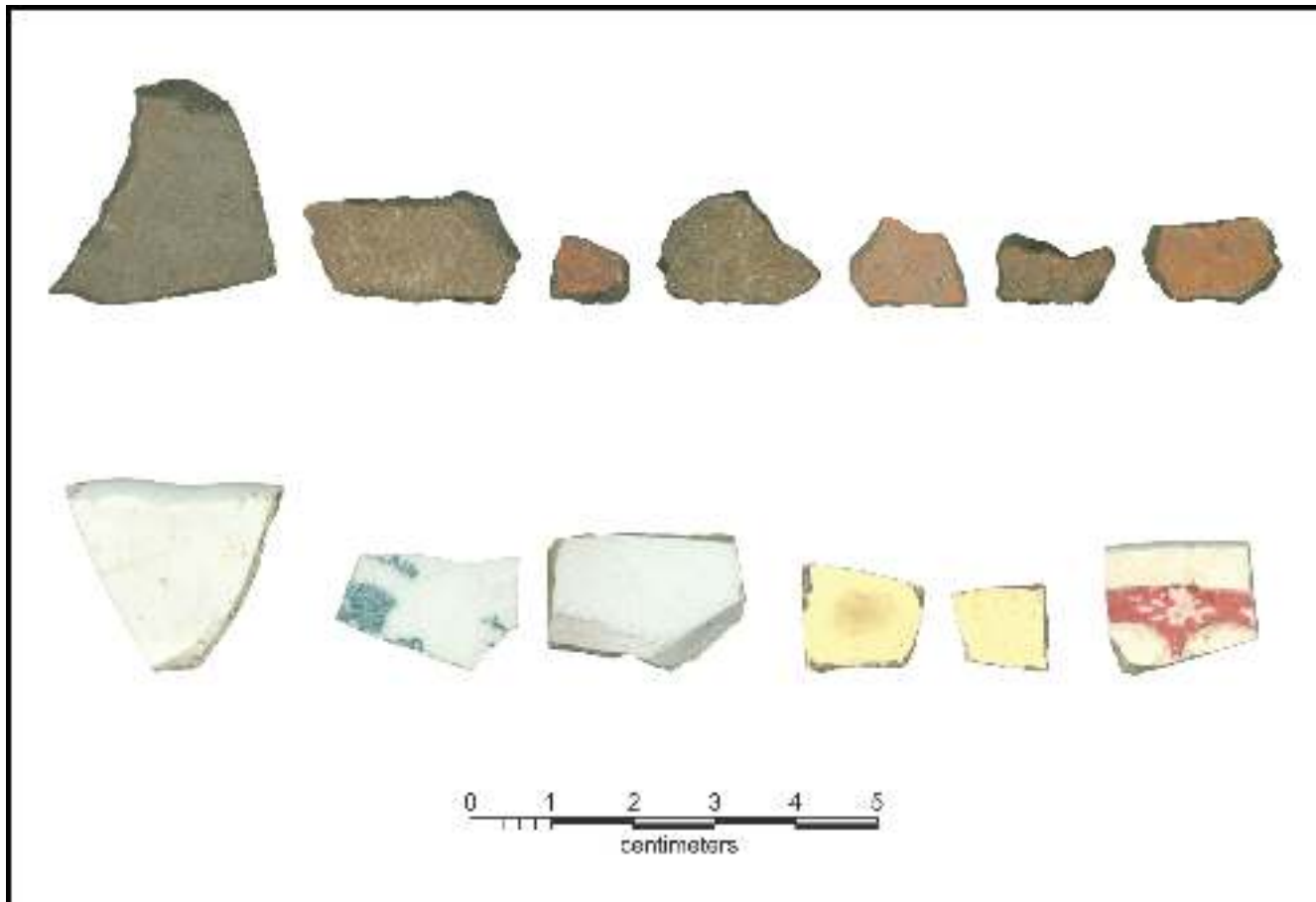

Figure 10-5. Selected ceramics recovered from San Pedro Park testing. Top row are Native American bone tempered sherds. Bottom row are various white wares, including two with a yellow glaze.

of TU 2 (10-20 cmbs), the lower deposits (90-100 cmbs) of TU 5, and the upper (20-40 cmbs) and lower (110-120 cmbs) deposits of TU 13. Two pieces were recovered from Levels 4 (30 to 40 cmbs) and 5 (40-50 cmbs) in TU 10. As discussed in the following chapter, there are data to suggest that in this setting, this depth is at or just below the level of disturbance. Consequently, while some items in this area, such as the piece recovered at 90-100 cmbs in TU 5 are out of context, others, like the 10-40 cm ceramic sherds, could be in stratigraphic order in this setting. The recovery from the upper levels of TU 13 is also of interest as this unit and level produced several pieces of white ware, including those pictured in Figure 10-5. However, as noted previously, material recovered from this unit appears to be out of context, with high frequencies of vertical cracking present in the clay deposits. The remaining sherds consist of white ware (n=15), yellow ware (n=1), stoneware (n=2), and two pieces, one of porcelain and one an earthenware that are probably from insulators.

As shown in Table 10-1, most of the ceramics fall within the late nineteenth or early twentieth century. Other than the Native American sherds, there are four sherds recovered from TUs 8 and 9 that might date to the mid-nineteenth century.

Vertebrate Fauna

Shovel testing and excavations recovered 1.98 kg of vertebrate fauna. Shovel testing produced only 158 grams of this total, test units produce 1.64 kg, and an additional 178 grams was collected from the backhoe trenching in the Map 4 area. The upper 30 cm of shovel testing produced 73.7 grams of vertebrate fauna. Most of the recovery from lower deposits was from a single level within ST 30, where 61 of the 84 grams were collected. While bone was present from all excavation units, the majority of the bone at a site level was in the Map 4 area, with TUs 4, 11, and 12 producing 1.14 kg, or about 58%, of the recovered vertebrate fauna by weight. TU 13, located in the Map 4 area, had bone present in a single level (20-40 cmbs), and TU 3, in the Map 2 area, had small amounts of bone in Levels 1 and 3. TU 7 (Map 1) had bone present from Levels 2-5, with the assemblage dominated by the remains of large and very large mammals, including one specimen identified as cow or bison. Several had hand-sawed cut marks, suggesting that the deposits contain some remains dating in the Historic Period. The only other remains with cut marks consistent with hand sawing were from TUs 8 and

9. These units, located in the Map 7 area and representing fill possibly related to construction in this area, had a small quantity of bone present.

Figure 10-6 shows the distribution of bone in the Map 6 area (TUs 1, 5, 6, and 10). Both the upper and lower levels lack any recovery, with bone primarily recovered in Levels 6 and 7. Figure 10-7 shows a similar graph for TU 4. Again, bone is absent from the upper levels and reduced in the lower levels; however, there is extremely high recovery from TU 4 in the middle levels of this deposit.

Table 10-2 lists the identified taxa recovered from the excavations. While a surprising variety of taxa is represented, remains from wood rats, the cotton rat, snakes, some birds, turtles, and fish are dominant. However, the recovery contexts of some of these clearly suggest their use as food. Others, such as bison, cottontail rabbit, domestic chicken, turkey, and white-tail deer, are from animals that were used for food. Bison was recovered from TU 2 at 10-20 cmbs and from TU 4 at 50-70 cmbs. Note that the TU 2 bison was radiocarbon dated to the proto-historic or early colonial occupation in San Pedro Park (see Appendix A). In addition, although no domestic cow specimens were identified, a variety of bovinæ (cow or bison) specimens were recovered, including several from the same contexts as bison, along with the remains of very large mammals that are in the size range of bison or

cow. One of these also has a proto-historic or early colonial radiocarbon date (Appendix A).

Given the high density of remains recovered in TU 4, it is not surprising that a variety of taxa is represented there. Table 10-3 provides details on the overall distribution, counts, and weights. Examination of the table shows that most of the material is from TU 4. These deposits include all sizes of mammals, including bison, deer, rabbits, and rodents such as the cotton rat and the wood rat. All sizes of birds are present, including turkey. The remains of several snakes, some of which are probably intrusive, as well as fish (gar) are present in these deposits.

These data clearly demonstrate the presence of a wide variety of animal remains in the deposits at San Pedro Park. The fauna recovered can provide detailed information on subsistence practices, especially for areas such as TU 4, where there is a substantial faunal assemblage and diversity, as well as for areas such as TU 2, where at least some of the fauna have a high probability of being directly associated with the proto-historic or colonial use.

Chipped Stone

Another class of material that is surprisingly common in these deposits is chipped stone debitage, tools, and cores. Over

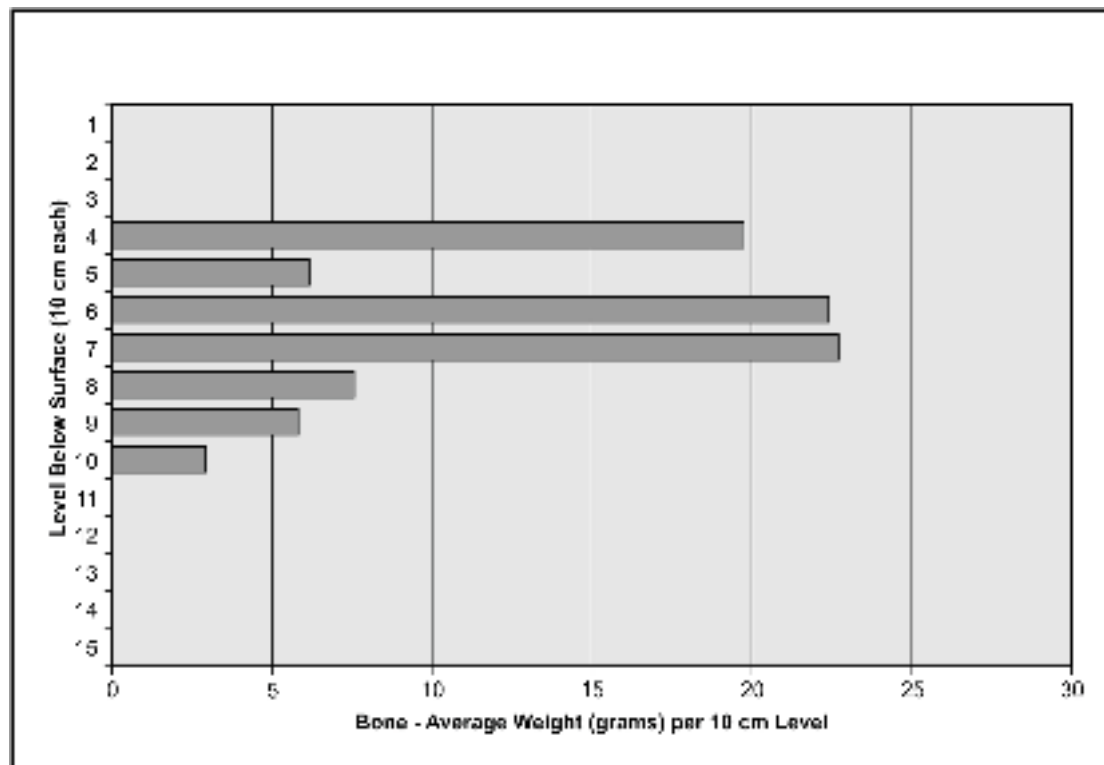

Figure 10-6. Bone weight (grams) by level in Map 6 area (Test Units 1, 5, 6, and 10).

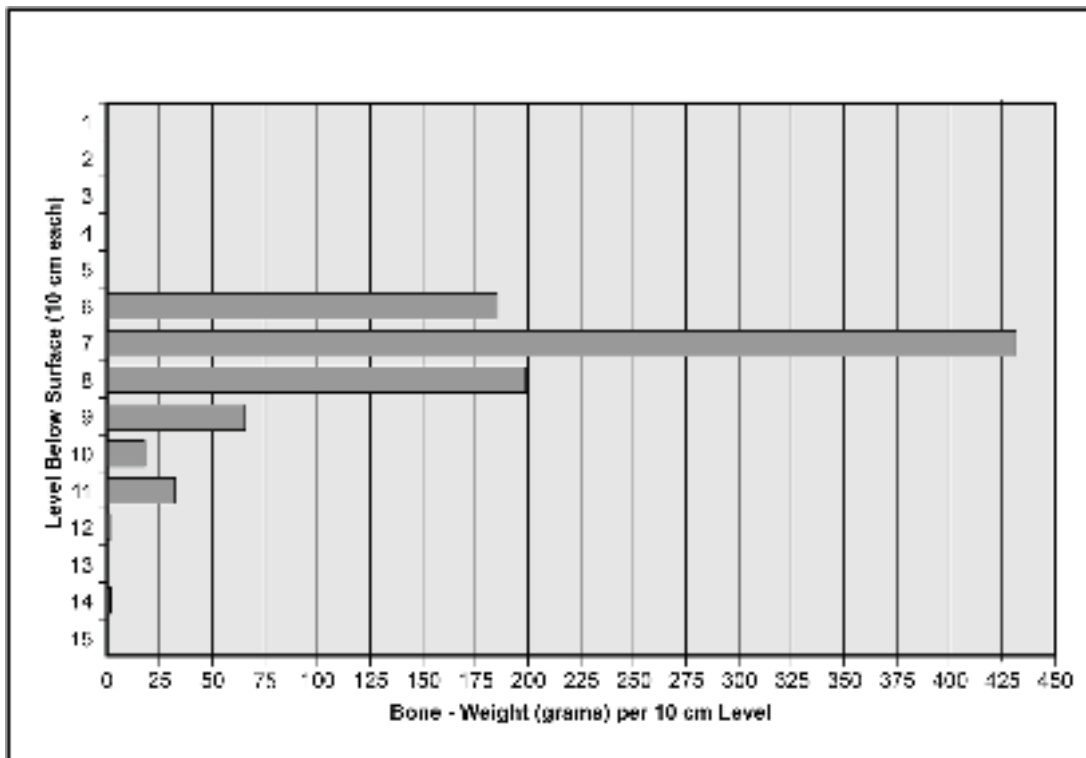

Figure 10-7. Bone weight (grams) by level in Map 4 area (Test Unit 4).

Table 10-2. Identified Taxa

Taxon	Common Name
<i>Bison bison</i>	American Bison
<i>Odocoileus virginianus</i>	Whitetail Deer
Bovinae	Cow or Bison
Artiodactyla	Deer, Sheep, Goat
<i>Neotoma</i> sp.	Woodrat
<i>Sigmodon hispidus</i>	Cotton Rat
<i>Sylvilagus</i> sp.	Cottontail Rabbits
Mammal	Size Indeterminate
Mammal—V. Sm.	Rat-/Mice-sized
Mammal—Sm.	Rabbit-sized
Mammal—Lg.	Deer-sized
Mammal—V. Lg.	Bison-/Cow-sized
<i>Gallus gallus</i>	Domestic Chicken
<i>Meleagris gallopavo</i>	Turkey
Columbidae	Doves, Pigeons
Galliformes	Turkeys, Chicken, Pheasants
Aves—Med.	Robin-sized
Aves—Lg.	Chicken-sized
Aves—V. Lg.	Turkey-sized

Table 10-2. Identified Taxa continued....

Taxon	Common Name
<i>Elaphe</i> sp.	Corn Snakes
<i>Nerodia</i> sp.	Water Snakes
Colubridae	Non-poisonous Snakes
Viperidae	Poisonous Snakes
Serpentes	Unidentified Snakes
<i>Apalone</i> sp.	Softshelled Turtles
Emydidae	Pond Sliders, Box Turtles
Testudines	Turtle
<i>Ictalurus</i> sp.	Freshwater Catfish
<i>Lepisosteus</i> sp.	Gars
Osteichthyes	Unidentified Boney Fish
Vertebrata	Unidentifiable Bone

Table 10-3. Taxon Distribution within Test Units

Taxon	Test Unit	Level	Depth	Count	Wgt. (g)
Mammal—Lg.	Test Unit 2	1	20-30 cmbd	2	0.85
<i>Bison bison</i>	Test Unit 2	2	30-40 cmbd	1	76.89
<i>Bison bison</i>	Test Unit 2	2	30-40 cmbd	3	33.32
Bovinae	Test Unit 2	2	30-40 cmbd	2	25.6
Mammal—V. Lg.	Test Unit 2	2	30-40 cmbd	9	29.75
Mammal	Test Unit 2	3	40-50 cmbd	7	1.03
Mammal—Lg.	Test Unit 2	3	40-50 cmbd	16	10.46
Mammal	Test Unit 2	4	50-60 cmbd	7	1.39
Mammal—Lg.	Test Unit 2	4	50-60 cmbd	4	3.51
Mammal—Lg.	Test Unit 1	4	50-60 cmbd	3	1.2
Mammal	Test Unit 1	5	60-70 cmbd	9	1.16
Mammal—Lg.	Test Unit 1	5	60-70 cmbd	6	5.02
<i>Sylvilagus</i> sp.	Test Unit 1	5	60-70 cmbd	1	0.18
Artiodactyla	Test Unit 1	6	70-80 cmbd	1	6.33
Aves—Lg.	Test Unit 1	6	70-80 cmbd	3	0.51
Mammal	Test Unit 1	6	70-80 cmbd	26	6.53
Mammal—Lg.	Test Unit 1	6	70-80 cmbd	5	6.02
Mammal—Sm.	Test Unit 1	6	70-80 cmbd	1	0.16
Artiodactyla	Test Unit 3	1	30-40 cmbd	1	0.78
Mammal—Lg.	Test Unit 3	1	30-40 cmbd	1	1.29
Artiodactyla	Test Unit 1	7	80-90 cmbd	3	4.7
Mammal	Test Unit 1	7	80-90 cmbd	24	4.89
Mammal—Lg.	Test Unit 1	7	80-90 cmbd	16	13.98
Rodentia	Test Unit 1	7	80-90 cmbd	1	0.13
Mammal—Lg.	Test Unit 3	3	50-60 cmbd	1	1.03

Table 10-3. Taxon Distribution within Test Units continued...

Taxon	Test Unit	Level	Depth	Count	Wgt. (g)
Aves—Lg.	Test Unit 1	8	90-100 cmbd	1	0.12
Colubridae	Test Unit 1	8	90-100 cmbd	1	0.08
Mammal	Test Unit 1	8	90-100 cmbd	22	3.21
Mammal—Lg.	Test Unit 1	8	90-100 cmbd	11	6.88
Aves—Lg.	Test Unit 4	5	65 cmbd	1	0.19
Vertebrata	Test Unit 4	5	65 cmbd	1	0.1
Mammal	Test Unit 4	5	70 cmbd	2	0.23
Mammal—Lg.	Test Unit 4	5	70 cmbd	2	1.44
Mammal	Test Unit 4	6	70-80 cmbd	146	38.92
Mammal—V. Lg.	Test Unit 4	6	70-80 cmbd	30	72.25
Mammal—Lg.	Test Unit 4	6	70-80 cmbd	65	49.48
<i>Bison bison</i>	Test Unit 4	6	70-80 cmbd	1	11.01
Bovinae	Test Unit 4	6	70-80 cmbd	1	7.78
<i>Apalone</i> sp.	Test Unit 4	6	70-80 cmbd	1	0.7
<i>Sigmodon hispidus</i>	Test Unit 4	6	70-80 cmbd	1	0.23
Rodentia	Test Unit 4	6	70-80 cmbd	4	0.62
Testudines	Test Unit 4	6	70-80 cmbd	1	0.09
<i>Sylvilagus</i> sp.	Test Unit 4	6	70-80 cmbd	2	1.85
Artiodactyla	Test Unit 4	6	70-80 cmbd	2	2.99
Aves—Med.	Test Unit 4	6	70-80 cmbd	1	0.19
Artiodactyla	Test Unit 4	7	80-90 cmbd	7	14.17
Aves—V. Lg.	Test Unit 4	7	80-90 cmbd	2	0.84
Aves—Sm.	Test Unit 4	7	80-90 cmbd	1	0.13
<i>Bison bison</i>	Test Unit 4	7	80-90 cmbd	1	2.82
Bovinae	Test Unit 4	7	80-90 cmbd	3	11.86
<i>Elaphe</i> sp.	Test Unit 4	7	80-90 cmbd	1	0.11
Columbidae	Test Unit 4	7	80-90 cmbd	2	0.17
Mammal	Test Unit 4	7	80-90 cmbd	247	49.48
Mammal—Lg.	Test Unit 4	7	80-90 cmbd	94	92.09
Mammal—V. Lg.	Test Unit 4	7	80-90 cmbd	29	158.83
<i>Meleagris gallopavo</i>	Test Unit 4	7	80-90 cmbd	1	0.19
<i>Odocoileus virginianus</i>	Test Unit 4	7	80-90 cmbd	3	6.43
<i>Sylvilagus</i> sp.	Test Unit 4	7	80-90 cmbd	1	0.38
Testudines	Test Unit 4	7	80-90 cmbd	6	1.37
Mammal—V. Lg.	Test Unit 4	7	80-90 cmbd	2	21.19
<i>Bison bison</i>	Test Unit 4	7	80-90 cmbd	1	24.02
<i>Apalone</i> sp.	Test Unit 4	8	90-100 cmbd	4	1.47
Artiodactyla	Test Unit 4	8	90-100 cmbd	12	36.76
Aves—Sm.	Test Unit 4	8	90-100 cmbd	3	0.43
<i>Lepisosteus</i> sp.	Test Unit 4	8	90-100 cmbd	1	0.13
Mammal	Test Unit 4	8	90-100 cmbd	180	33.23
Mammal—Lg.	Test Unit 4	8	90-100 cmbd	65	52.67
Mammal—V. Lg.	Test Unit 4	8	90-100 cmbd	19	27.88

Table 10-3. Taxon Distribution within Test Units continued...

Taxon	Test Unit	Level	Depth	Count	Wgt. (g)
<i>Neotoma</i> sp.	Test Unit 4	8	90-100 cmbd	2	0.21
<i>Odocoileus virginianus</i>	Test Unit 4	8	90-100 cmbd	4	24.78
Osteichthyes	Test Unit 4	8	90-100 cmbd	2	0.63
Rodentia	Test Unit 4	8	90-100 cmbd	2	0.34
Serpentes	Test Unit 4	8	90-100 cmbd	1	0.04
<i>Sylvilagus</i> sp.	Test Unit 4	8	90-100 cmbd	1	0.12
Testudines	Test Unit 4	8	90-100 cmbd	5	2.23
Viperidae	Test Unit 4	8	90-100 cmbd	1	0.14
Artiodactyla	Test Unit 4	9	100-110 cmbd	2	1.94
Aves—Lg.	Test Unit 4	9	100-110 cmbd	2	0.19
Colubridae	Test Unit 4	9	100-110 cmbd	1	0.12
<i>Lepisosteus</i> sp.	Test Unit 4	9	100-110 cmbd	1	0.05
Mammal	Test Unit 4	9	100-110 cmbd	71	13.66
Mammal—Lg.	Test Unit 4	9	100-110 cmbd	28	20.52
Mammal—Sm.	Test Unit 4	9	100-110 cmbd	3	0.46
Mammal—V. Lg.	Test Unit 4	9	100-110 cmbd	1	3.69
Osteichthyes	Test Unit 4	9	100-110 cmbd	1	0.21
<i>Sylvilagus</i> sp.	Test Unit 4	9	100-110 cmbd	5	1.94
Testudines	Test Unit 4	9	100-110 cmbd	3	0.61
Bovinae	Test Unit 4		Wall fall	1	7.38
Mammal	Test Unit 4		Wall fall	14	3.37
<i>Neotoma</i> sp.	Test Unit 4		Wall fall	1	0.05
Mammal—Lg.	Test Unit 4		105 cmbd	1	13.1
Artiodactyla	Test Unit 4	10	110-120 cmbd	1	1.15
Mammal	Test Unit 4	10	110-120 cmbd	31	6.18
Mammal—Lg.	Test Unit 4	10	110-120 cmbd	9	5.21
Mammal—V. Lg.	Test Unit 4	10	110-120 cmbd	2	2.36
Vertebrata	Test Unit 4	10	110-120 cmbd	4	1.71
Mammal	Test Unit 4	12	130-140 cmbd	6	1.42
Mammal—Sm.	Test Unit 4	12	130-140 cmbd	1	0.07
<i>Sylvilagus</i> sp.	Test Unit 4	12	130-140 cmbd	1	0.12
Mammal	Test Unit 4	14	150-160 cmbd	2	0.48
Mammal—Lg.	Test Unit 4	14	150-160 cmbd	2	1.05
Artiodactyla	Test Unit 5	6	70-80 cmbd	1	0.97
Aves—Sm.	Test Unit 5	6	70-80 cmbd	2	0.12
Bovinae	Test Unit 5	6	70-80 cmbd	1	2.34
Mammal	Test Unit 5	6	70-80 cmbd	14	2.51
Mammal—Lg.	Test Unit 5	6	70-80 cmbd	1	0.38
Mammal—V. Lg.	Test Unit 5	6	70-80 cmbd	6	7.52
Rodentia	Test Unit 5	6	70-80 cmbd	2	0.17
<i>Sylvilagus</i> sp.	Test Unit 5	6	70-80 cmbd	1	0.21
Testudines	Test Unit 5	6	70-80 cmbd	6	2.27
Mammal	Test Unit 5	6	77 cmbd	4	0.38

Table 10-3. Taxon Distribution within Test Units continued...

Taxon	Test Unit	Level	Depth	Count	Wgt. (g)
Mammal—V. Lg.	Test Unit 5	6	77 cmbd	4	7.21
Mammal—Lg.	Test Unit 5	6	76 cmbd	1	4.28
Mammal—Lg.	Test Unit 6	6	70-80 cmbd	5	2.16
Mammal	Test Unit 6	7	80-90 cmbd	7	0.79
Mammal—Lg.	Test Unit 6	7	80-90 cmbd	8	5.41
Mammal—V. Sm.	Test Unit 6	7	80-90 cmbd	2	0.2
Aves—Lg.	Test Unit 5	7	80-90 cmbd	3	0.57
Aves—Med.	Test Unit 5	7	80-90 cmbd	2	0.18
Mammal	Test Unit 5	7	80-90 cmbd	56	8.08
Mammal—Lg.	Test Unit 5	7	80-90 cmbd	23	19.76
Mammal—V. Lg.	Test Unit 5	7	80-90 cmbd	8	8.66
Testudines	Test Unit 5	7	80-90 cmbd	3	0.82
Colubridae	Test Unit 6	8	90-100 cmbd	1	0.05
Mammal	Test Unit 6	8	90-100 cmbd	2	0.71
Mammal—V. Sm.	Test Unit 6	8	90-100 cmbd	1	0.07
Artiodactyla	Test Unit 5	8	90-100 cmbd	3	1.09
Aves—Lg.	Test Unit 5	8	90-100 cmbd	3	0.48
Emydidae	Test Unit 5	8	90-100 cmbd	2	1.01
<i>Ictalurus</i> sp.	Test Unit 5	8	90-100 cmbd	1	0.19
Mammal	Test Unit 5	8	90-100 cmbd	40	6.13
Mammal—Lg.	Test Unit 5	8	90-100 cmbd	9	4.97
Mammal—Sm.	Test Unit 5	8	90-100 cmbd	1	0.77
Mammal—V. Lg.	Test Unit 5	8	90-100 cmbd	1	0.34
<i>Sylvilagus</i> sp.	Test Unit 5	8	90-100 cmbd	1	0.19
Testudines	Test Unit 5	8	90-100 cmbd	6	1.47
Aves—Med.	Test Unit 5	9	100-110 cmbd	4	0.29
Mammal	Test Unit 5	9	100-110 cmbd	21	3.79
Mammal—Lg.	Test Unit 5	9	100-110 cmbd	8	9.23
Rodentia	Test Unit 5	9	100-110 cmbd	1	0.06
Testudines	Test Unit 5	9	100-110 cmbd	3	1.38
Emydidae	Test Unit 5	10	110-120 cmbd	1	0.49
Mammal	Test Unit 5	10	110-120 cmbd	10	2.35
Mammal—Lg.	Test Unit 5	10	110-120 cmbd	1	0.83
Testudines	Test Unit 5	10	110-120 cmbd	4	3.29
Testudines	Test Unit 5	10	120 cmbd	1	0.6
Mammal	Test Unit 7	3	40-50 cmbd	4	0.62
Mammal—Lg.	Test Unit 7	3	40-50 cmbd	3	1.5
Aves—Lg.	Test Unit 7	3	40-50 cmbd	2	0.25
Mammal—V. Lg.	Test Unit 7	4	50-60 cmbd	10	14.18
Mammal—Lg.	Test Unit 7	4	50-60 cmbd	1	9.12
Mammal	Test Unit 7	4	50-60 cmbd	20	4.53
<i>Odocoileus virginianus</i>	Test Unit 10	4	50-60 cmbd	1	1.23
Mammal—V. Lg.	Test Unit 10	4	50-60 cmbd	13	51.39

Table 10-3. Taxon Distribution within Test Units continued....

Taxon	Test Unit	Level	Depth	Count	Wgt. (g)
Mammal—Lg.	Test Unit 10	4	50-60 cmbd	23	17.95
Mammal	Test Unit 10	4	50-60 cmbd	20	3.03
Bovinae	Test Unit 7	5	60-70 cmbd	1	4.7
Mammal—Lg.	Test Unit 7	5	60-70 cmbd	1	0.85
Aves—Lg.	Test Unit 9	3	50-60 cmbd	2	0.27
Testudines	Test Unit 9	3	50-60 cmbd	1	0.28
Mammal—Lg.	Test Unit 9	3	50-60 cmbd	1	0.58
Mammal	Test Unit 9	3	50-60 cmbd	3	0.57
<i>Odocoileus virginianus</i>	Test Unit 10	6	70-80 cmbd	2	4.14
Mammal—V. Lg.	Test Unit 10	6	70-80 cmbd	7	21.32
Mammal—Lg.	Test Unit 10	6	70-80 cmbd	9	4.17
Mammal	Test Unit 10	6	70-80 cmbd	3	0.53
Mammal—V. Lg.	Test Unit 9	6	80-90 cmbd	2	0.43
Artiodactyla	Test Unit 10	7	80-90 cmbd	2	4.43
Mammal—Lg.	Test Unit 10	7	80-90 cmbd	5	5.16
Mammal	Test Unit 10	7	80-90 cmbd	19	4.63
Testudines	Test Unit 10	7	80-90 cmbd	3	0.28
Mammal	Test Unit 9	8	100-110 cmbd	1	0.22
Mammal—V. Lg.	Test Unit 8	9	110-120 cmbd	1	0.84
Mammal—V. Lg.	Test Unit 8	12	140-160 cmbd	4	14.3
Galliformes	Test Unit 8	12	140-160 cmbd	1	0.6
Bovinae	Test Unit 8	13	160-170 cmbd	1	8.32
Mammal—Lg.	Test Unit 11	2	47-57 cmbd	1	0.32
Mammal—Sm.	Test Unit 12	1	37-47 cmbd	2	0.51
Bovinae	Test Unit 9	1	30-40 cmbd	1	35.29
Mammal—V. Lg.	Test Unit 9	2	40-50 cmbd	4	23.93
Mammal—Lg.	Test Unit 13	2	40-60 cmbd	3	1.29

10,000 pieces of chipped stone were recovered, including over 9,900 pieces of debitage, and roughly 138 lithic tools and cores. Shovel tests recovered 516 pieces of chipped stone, with most (70.6%) recovered from below 30 cm. Like faunal material, the Map 4 area contained the majority (55.7%) of the items recovered from testing. The Map 6 area, with TUs 1, 5, 6, and 10, also produced a high recovery rate, with just over 3,200 items recovered. TU 2, located in the Map 3 area, produced about 400 items, and TU 13 had high recovery, with 424 items. TUs 3 (n=98), 7 (n=37) and TUs 8 and 9 (n=44) had moderate-to-low recovery, especially in TUs 8 and 9. In all cases, chert was the predominate material. Tools recovered included 77 bifaces, 20 of which likely functioned as projectile points, a variety of edge modified or utilized flakes, two possible ground stone fragments, a possible hammer stone, several unifaces, and 28 cores.

Debitage

Chipped stone debitage was present in moderate-to-high quantities in all areas sampled. Focusing on the debitage recovered from test units, cortex was recorded as absent, 1-50%, 51-99%, or 100%. Overall, 78.9% of the testing debitage lacked cortex and were classified as tertiary flakes. Flakes in the intermediate groups, generally classified as secondary flakes, made up 14.4% (1-50% cortex) and 5.2% (51-99% cortex) of the recovered debitage. Primary flakes, those that had 100% dorsal cortex cover, made up 1.5% of the debitage recovered. The two major determinates of cortex percentage are the degree of tool reduction and the availability of larger size raw material sources, with greater reduction and larger raw materials generally yielding higher tertiary percentages (e.g., Andrefsky 1998). In a general

review of reduction patterns and chert availability for 34 central Texas counties and over 200 site reports, Mauldin and Figueroa (2006) have shown that when raw material is readily available, tertiary flake percentages tend to fall between 75 and 84%. The recorded tertiary percentage at 41BX19 falls within that overall pattern and is consistent with high quality, large size chert sources available along the Edwards/Balcones Escarpment.

Table 10-4 presents totals at the unit level of flakes reviewed and the percentage of tertiary flakes at the unit level. Also included is information on several general size groups, established with nested screens of sizes 1-, ½-, and ¼-inch mesh. The last column of the table shows the percentage of items less than a half-inch in maximum size within the unit. Overall, 79% of the flakes in these nine units are less than one inch in maximum size.

Focusing initially on the tertiary percentages in the table, note that two of the units, TUs 7 and 13, have values that are significantly below the overall average of roughly 78%. While the TU 7 pattern may simply be a sampling issue and influenced by the smaller sample size for debitage, this area also had faunal material recovered with a relatively high frequency of hand-sawed bone and a higher density of ceramics. The pattern in TU 13 might be related to the overall larger size of debitage in this unit. Larger flakes tend to have a lower frequency of cortex, and the fact that roughly 28% of the material from this unit is larger than a half-inch might account for the lower tertiary percentage. It is not clear why the flakes in this setting would be smaller, though if this does represent a secondary deposit, with fill brought into the location, then some size sorting may have occurred previously. Finally, note that the debitage in TU 2 is noticeably smaller than that recovered from other areas of the site.

Figures 10-8, 10-9, and 10-10 present data on the distribution of debitage by level for TUs 2 (Map 3), 1 (Map 6), and 4 (Map 4). Consideration of the three graphs shows that TU 2 also differs in the distribution of material. Almost all of the debitage in TU 2 occurs above 40 cm, with most occurring in Level 3 (20–30 cmbs). In contrast, the distribution of debitage within other units tends to have low densities above 40 cm and peak densities at greater depths (Figures 10-9 and 10-10).

The patterns in Figures 10-9 and 10-10 are essentially replicated by distributions of debitage in TUs 5, 6, and 10, with low densities in the upper ranges and high densities in the deeper ranges. A similar pattern is also present in the shovel test data, as noted above. Given general indicators of disturbance in these upper levels, one possibility is that the TU 2 material has been redeposited. This may account for the significantly smaller size of that material as well. While this possibility should be investigated by consideration of breakage patterns, note that a comparison of the size range of the upper 40 cm of this unit shows that 90.3% of the material is within the smallest size grade. Only 73.3% of the lower material in this same unit falls within the smallest size grade. Conversely, the peak in TU 22 could represent a more recent deposit that has been destroyed in other contexts. The size differences in debitage could reflect the use of different lithic reduction strategies late in time. The possibility of a different reduction strategy is especially interesting given that Level 2 of this unit returned a radiocarbon date (CAR 344) that was most likely reflecting a proto-historic/colonial age range.

Chipped Stone Tools and Cores

A variety of tools were recovered from across the site, in both test units and shovel tests. The primary focus here is on bifacial tools, especially those bifaces that have a hafting element present suggesting their use as projectile points. Figure 10-

Table 10-4. Debitage Cortex and Size for Test Units

Unit	# Reviewed	% Tertiary	.25-.5 in	.5-1.0	% in small group
1	975	78.2	737	199	75.6
5	584	82.2	444	120	76
6	732	79.5	579	129	79.1
10	842	81.2	646	171	76.7
2	391	80.1	348	41	89
7	35	60	29	6	82.9
3	98	76.5	75	21	76.5
13	421	67.5	302	107	71.7
4	4134	79.5	3332	717	80.6

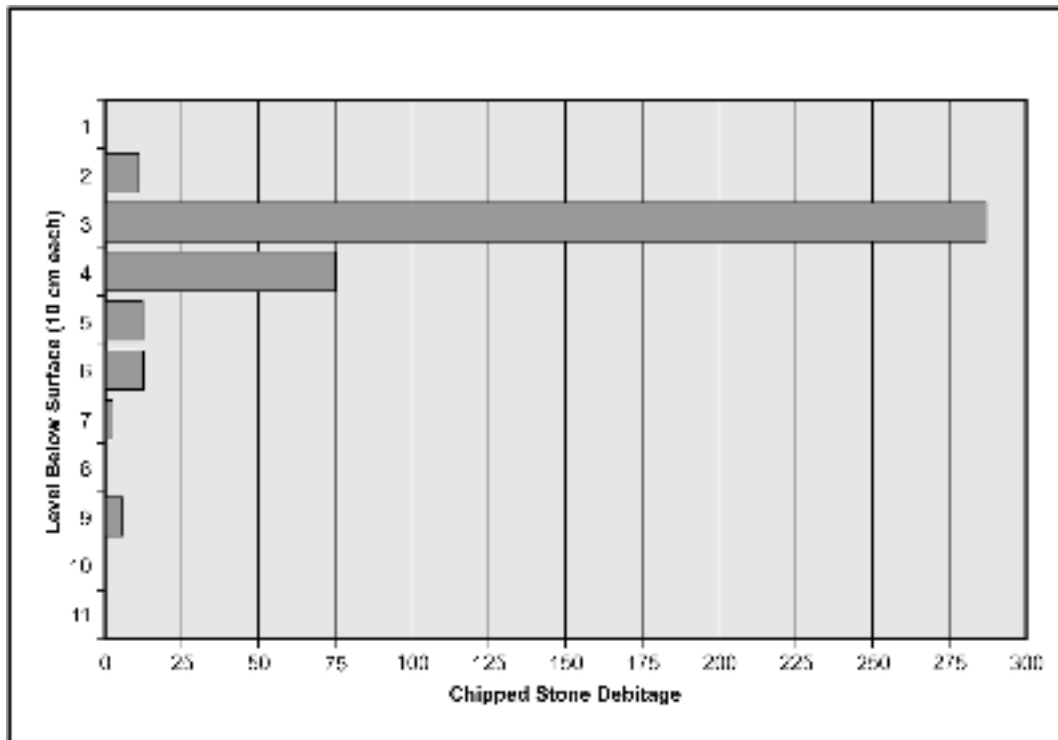

Figure 10-8. Chipped stone debitage counts by 10-cm level, Test Unit 2 (Map 3 area).

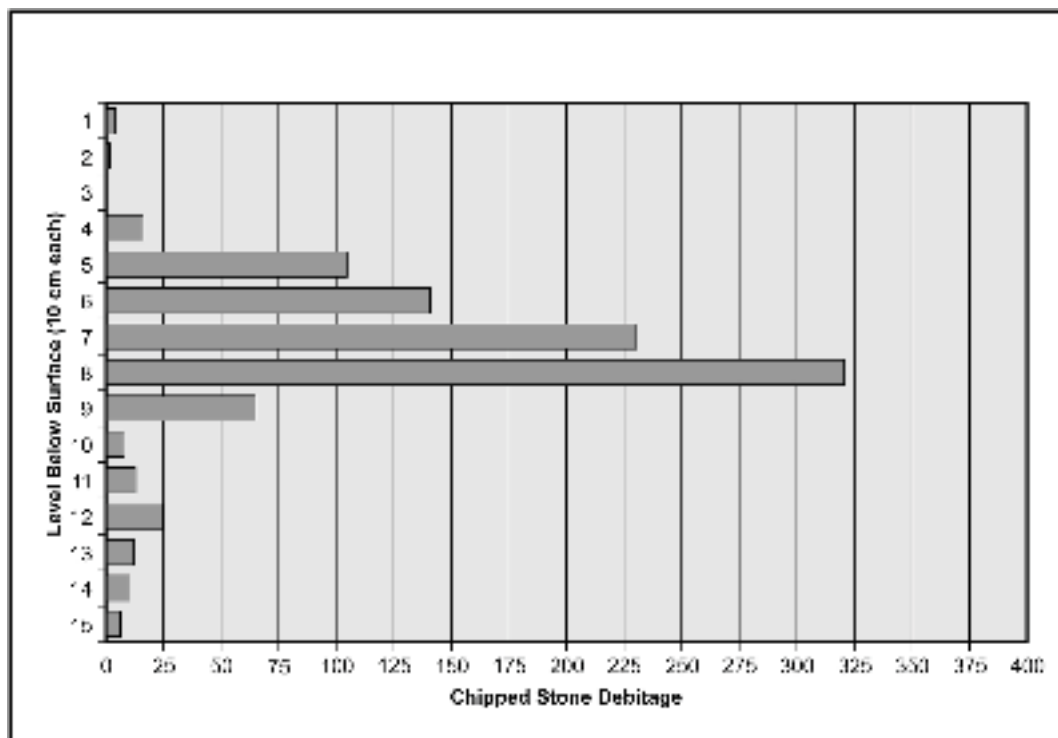

Figure 10-9. Chipped stone debitage counts by 10-cm level, Test Unit 1 (Map 6 area).

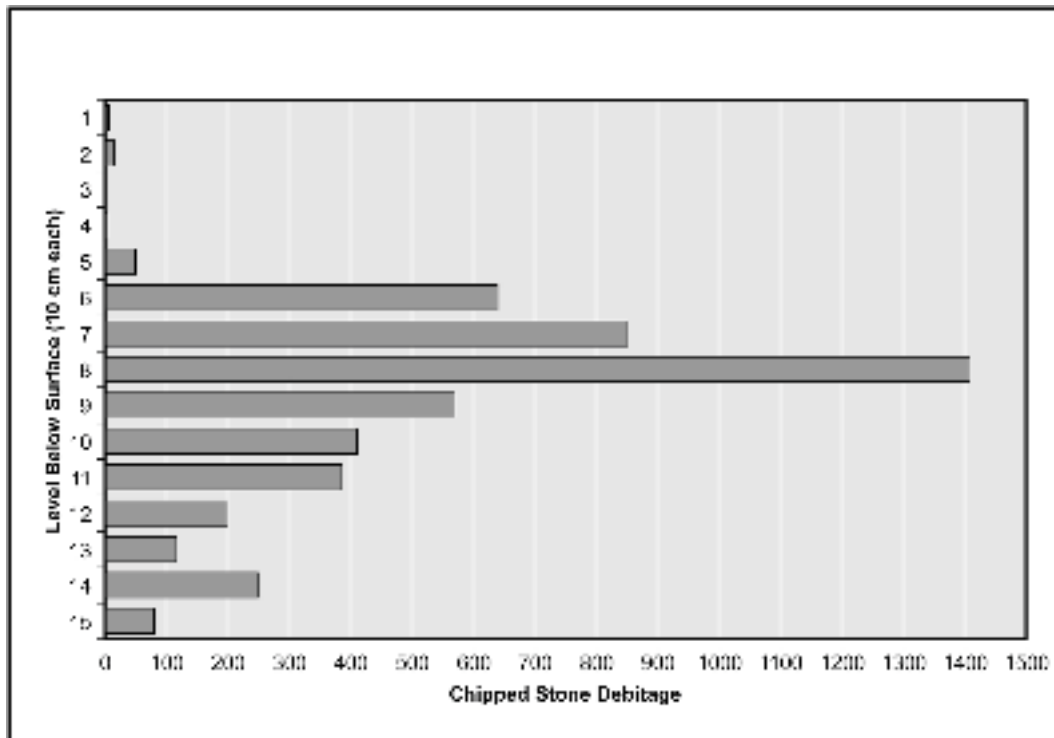

Figure 10-10. Chipped stone debitage counts by 10-cm level, Test Unit 4 (Map 4 area).

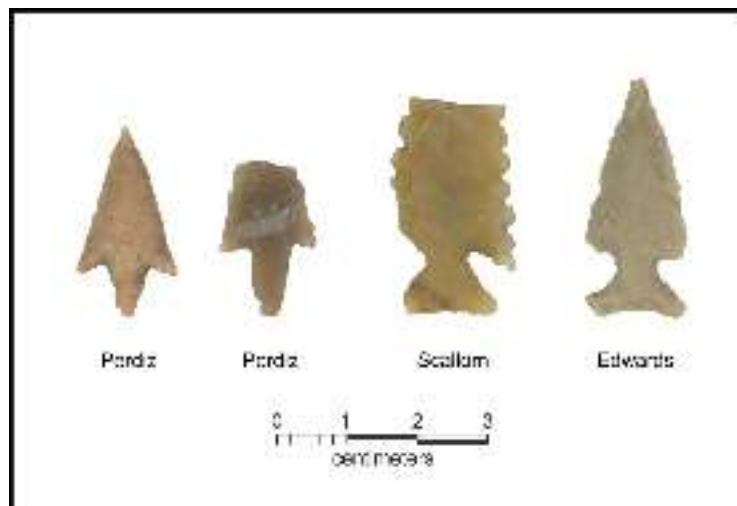

Figure 10-11. Late Prehistoric points recovered from San Pedro Park testing.

11, which presents four Late Prehistoric forms, is the first of several panels showing projectile points. Turner et al. (2011), Turner and Hester (1999), and Davis (1991) were used to type these specimens. As noted in Chapter 8, the Late Prehistoric Toyah interval Perdiz points were recovered from TU 1, at 40-50 cmbs and from 30-40 cmbs in TU 10. Both of these are in the Map 6 area. While there are no associated corresponding radiocarbon dates from these units, TU 5 in this area has a number of radiocarbon dates (see Chapter 8; Appendix A), including a Late Prehistoric Austin interval radiocarbon date

(Beta 390004) in Level 9 (80-90 cmbs) and a proto-historic/colonial date in Level 6 (50-60 cmbs). The Edwards point in Figure 10-11 was from TU 2. Interestingly, the Edwards point was recovered from Level 3, the same level with the high-density peak and small overall debitage size discussed above. In addition, this area has the second proto-historic/colonial date (CAR 346) from Level 2 of TU 2, which lends support to the idea that this area represents a more recent occupation rather than a redeposit assemblage. Finally, the Scallorn point was from the upper levels of ST 81.

Figure 10-12 presents several Late Archaic point forms that appear to date between roughly 2000 and 1200 BP (Collins 2004). These were recovered from the TU 4, with the exception of the possible Castroville on the far right, recovered from TU 6 at 50-60 cmbs. These other Late Archaic forms were predominately recovered from 50-90 cmbs in TU 4.

Figure 10-13 presents slightly earlier Late Archaic forms. The tentatively identified Lange form was from TU 1 at 50-60 cmbs, while the Pedernales was recovered from TU 4 at 80-90 cmbs. Finally, the possible La Jita form, recovered from TU 6 at 70-80 cmbs, could date to the end of the Middle Archaic, ca. 4200 BP.

It is generally the case that these points are in broad stratigraphic context within a given unit. This is especially apparent in TU 4, where high recovery and carbonate coating on artifacts at depth provide many opportunities to identify

items that were out of context. There was an occasional flake mixed in with carbonate-covered items, but the overwhelming majority of debitage and tools appeared to be consistently in broad stratigraphic order. Figures 10-14 through 10-16 show the variety of formal, predominantly bifacial, tools recovered, along with information on their recovery context. Note that depths are referenced as cm below the datum (cmbd) for test units and that the string lines were consistently placed at 20 cm above the ground surface. Several of these items appear to have been hafted, and some could be classified as projectile points, though none of these can be types. In addition, several other tools, such as the possible Guadalupe Adze from TU 4 (Figure 10-14, far right), may have temporal affiliations.

These tools, like the debitage, are dominated by collections from the Map 4 area, including TU 4 and the two backhoe trenches. This material dates primarily to the Late Archaic.

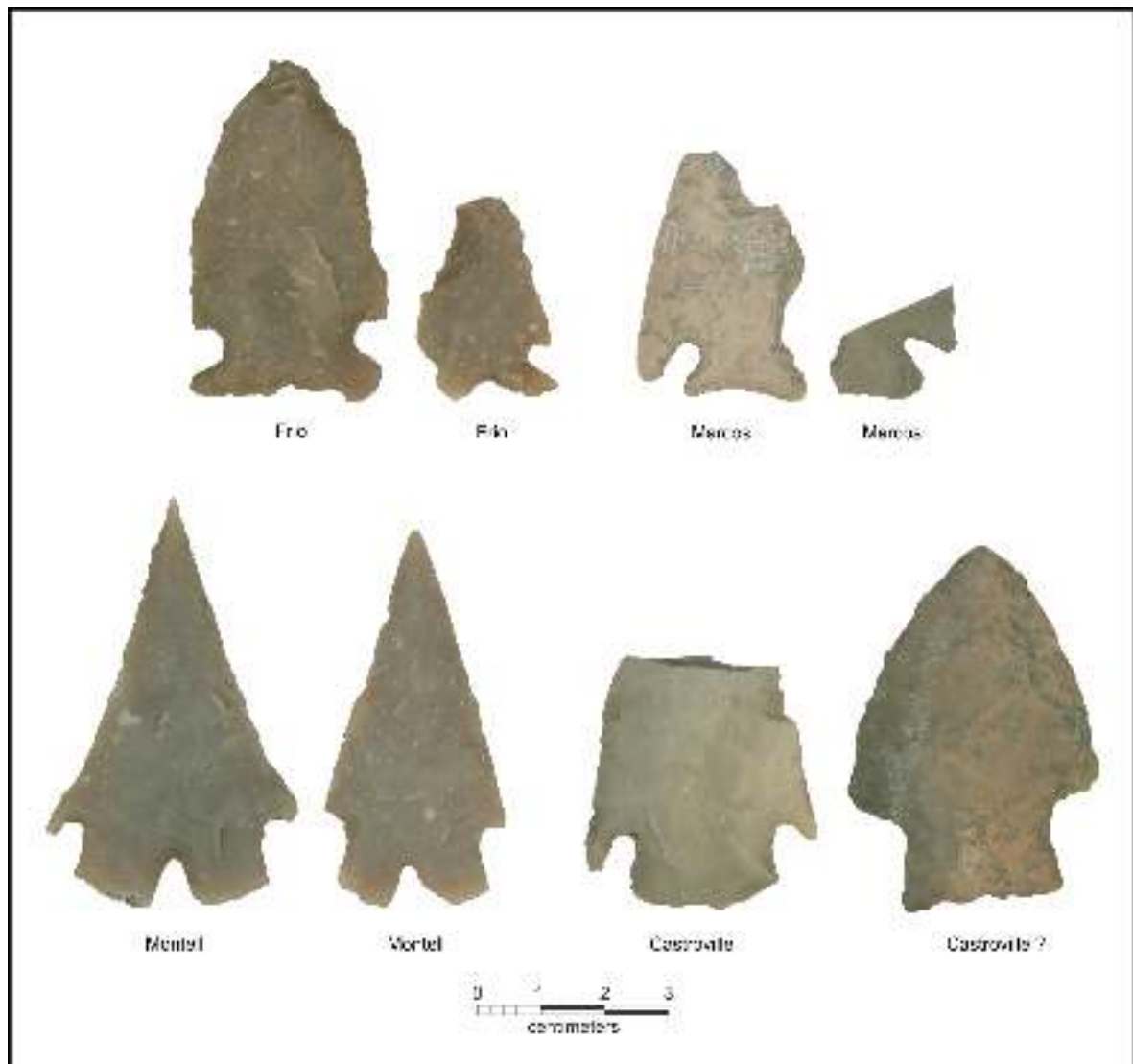

Figure 10-12. Late Archaic points recovered from San Pedro Park testing.

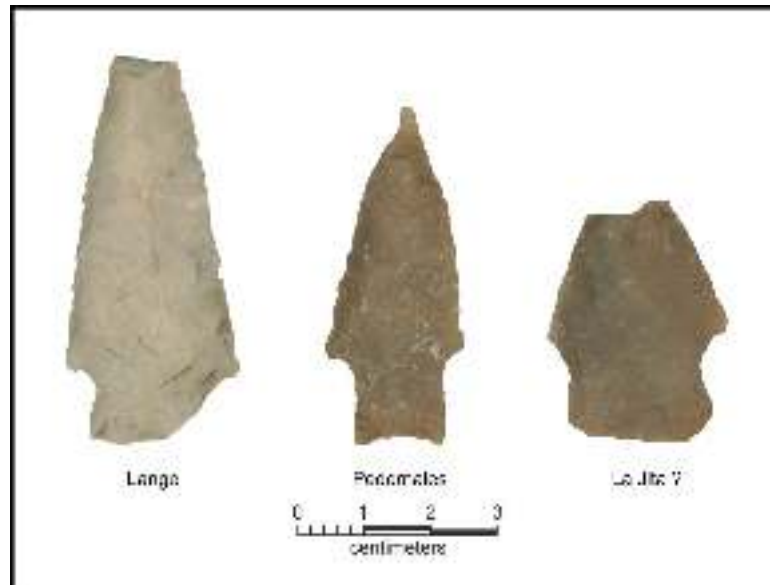

Figure 10-13. Earlier point forms recovered from San Pedro Park testing.

Lower material may date to the Early Archaic, based on the recovery of a possible Guadalupe tool (Figure 10-14; Turner et al. 2011). However, as noted previously, there is some mixing of material in this test unit, probably a result of rodent disturbance. The single radiocarbon date, from Level 9, returned a Toyah interval Late Prehistoric date (Beta 390003; Appendix A) though this and adjacent levels are dominated by Late Archaic forms, and there are several pieces of historic brick and tile scattered in these lower TU 4 deposits.

Bifaces, including projectile points, dominated the assemblage. While there are also several unifaces, two possible ground stone fragments, and a possible hammerstone fragment, the next largest sample size is made up of edge-modified items, including utilized flakes. In all, there were 27 of these recovered. Figure 10-17 presents the weight of these tools. There is clearly a bimodal distribution, with 10 of the 27 weighing between 37.5 and 100 grams. The clear separation is suggestive of two different functional groups, though additional investigation is needed to verify and better define the groups.

The other major group recovered was cores. In all, 28 cores were collected, with 15 of these from Map 4 area. All cores are chert, and most that have cortex patterns consistent with use are nodules in the 6- to 7-cm size range. Figure 10-18 shows the weight (grams) distribution of these items. The upper mode in the figure tends to be items minimally reduced, and there are only a few specimens that could be characterized as exhausted.

Burned Rock

Burned rock, primarily limestone, is common within the investigated deposits, and it represents the by-product of heating. This section presents a summary of data from several different areas of the site. These data were generated by initially sorting all burned rock through ½-inch mesh. Rock was then sized and weighed. Two areas of the site, Maps 4 and 6, have large quantities of rock.

Figure 10-19 presents the weight (kilograms) of burned rock for TU 4 by level. The pattern shown is broadly similar to that shown for the debitage (Figure 10-10). The initial levels have little recovery, and then there are two broad peaks. The upper peak (red), initially associated with Level 7, has a large quantity of rock and, based on projectile point forms, dates in the Late Archaic. The lower, smaller peak (orange) may date to the Early Archaic based on the recovery of specific tool forms, though that determination is tentative.

Figure 10-20 presents the weight of burned rock for TU 1 by level. This unit was the center point of explorations in the Map 6 area. A burned rock feature, designated Feature 1, was recorded in Levels 8 and 9. The distribution of rock in the figure shows the feature levels (red), with both levels having the highest recorded burned rock weights for an excavated level on the project. While the Figure 10-20 pattern is dominated by the two peaks, in general outline of the rock distribution is similar to that of the debitage for this unit (see Figure 10-9).

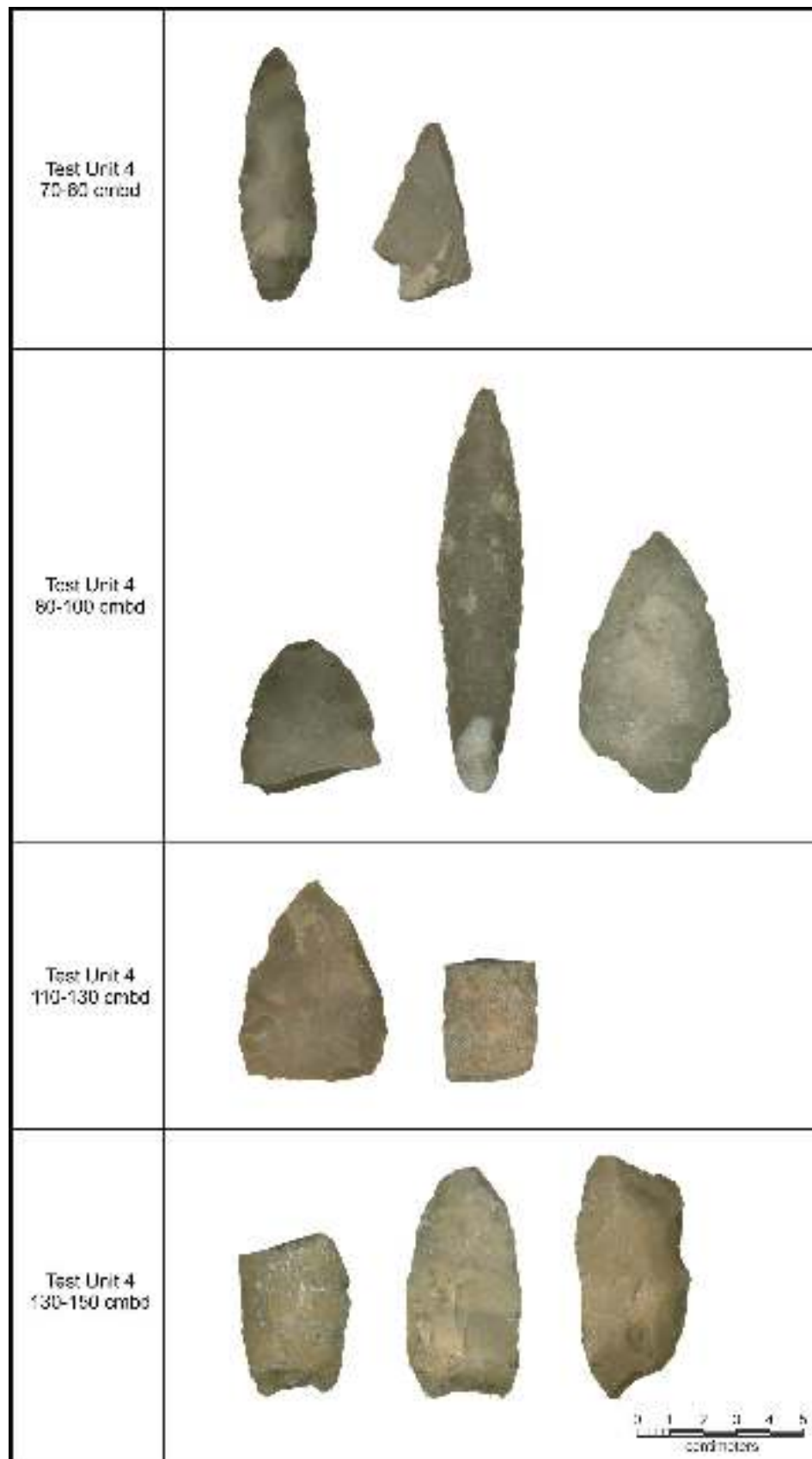

Figure 10-14. Selected Test Unit 4 bifacial tools, San Pedro Park testing.

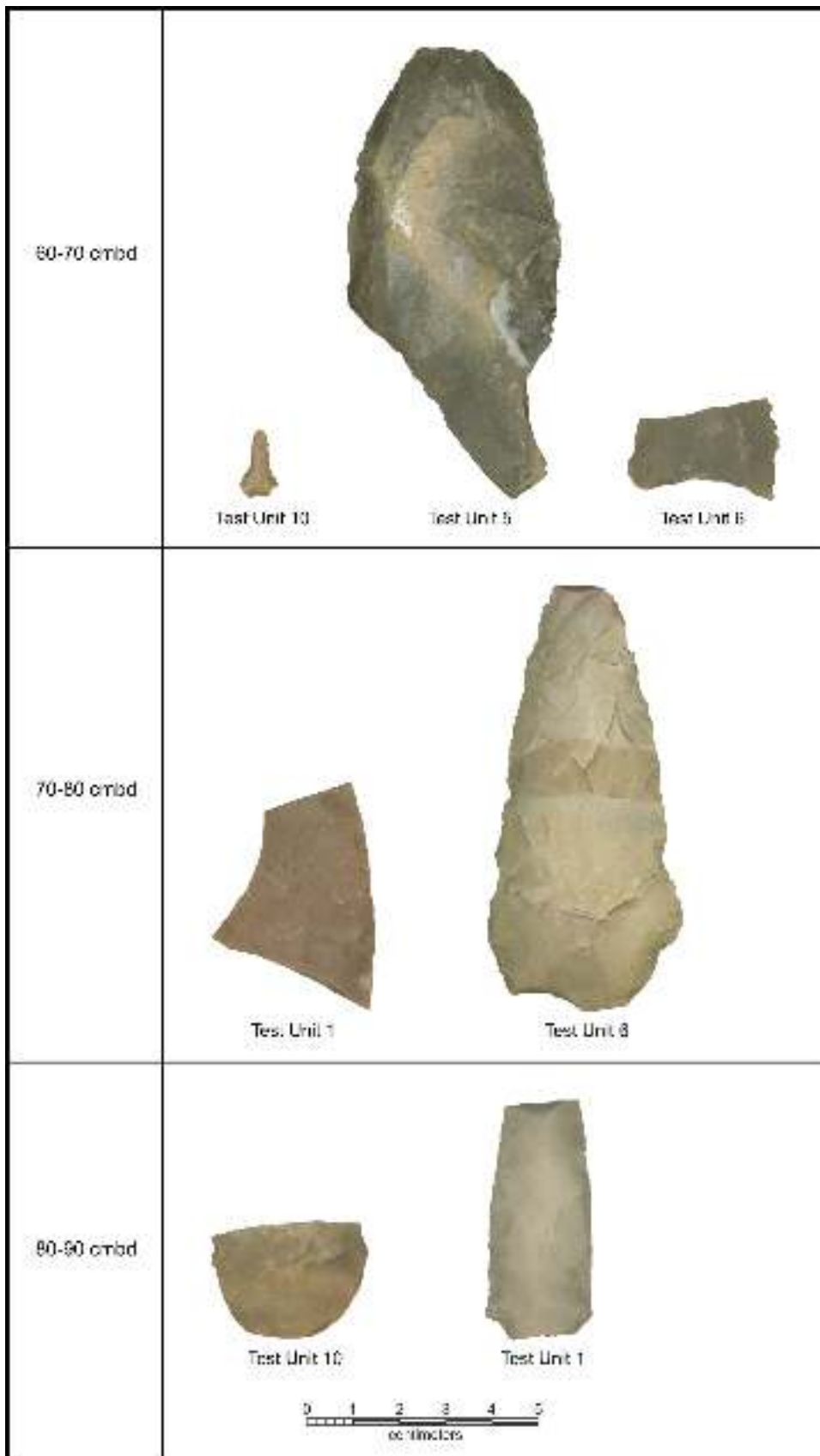

Figure 10-15. Selected formal tools from San Pedro Park testing.

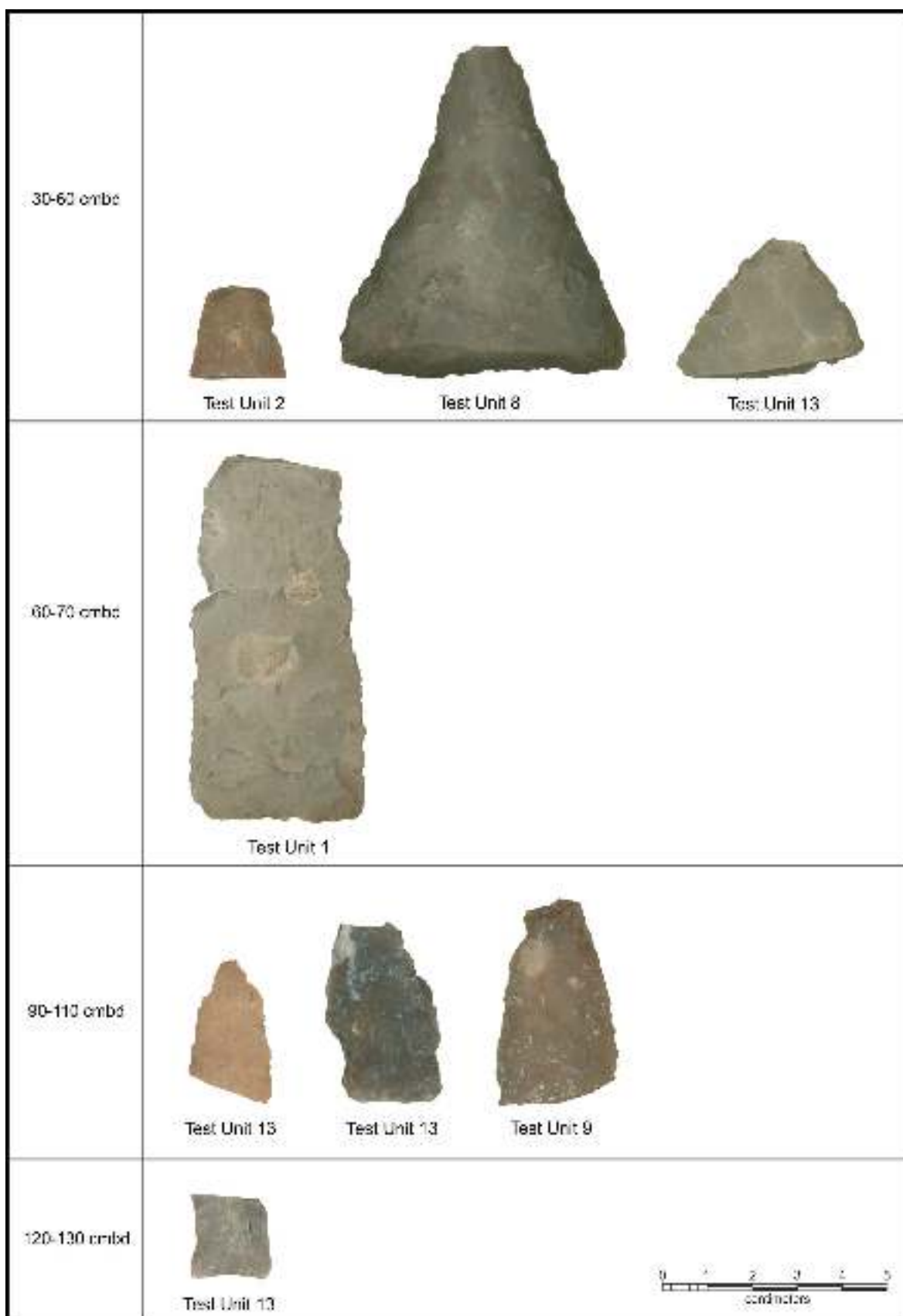

Figure 10-16. Selected bifacial tools and fragments recovered from San Pedro Park testing.

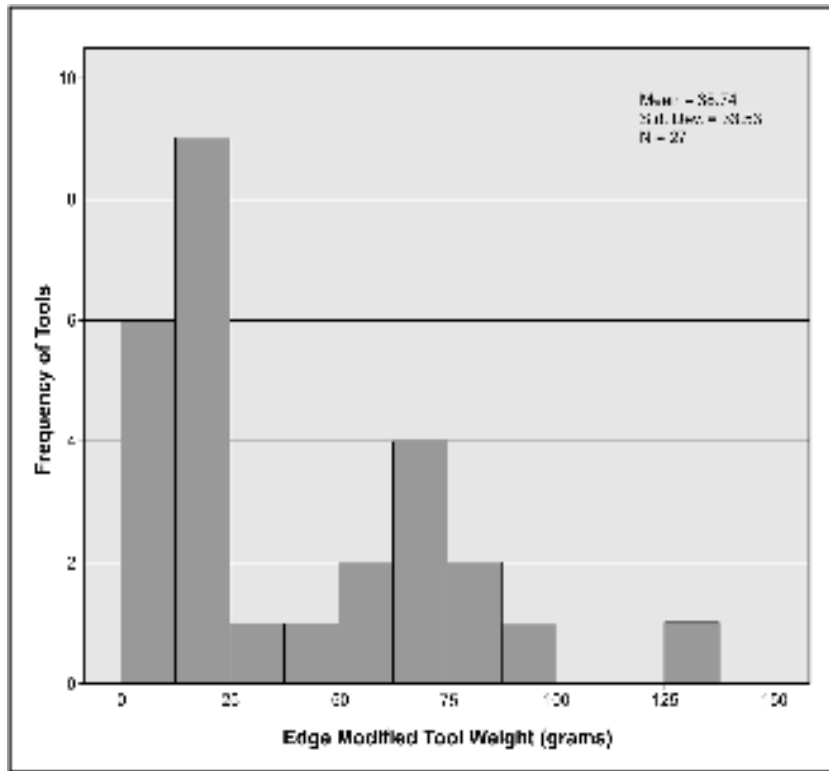

Figure 10-17. Weight (grams) of edge modified tools recovered from San Pedro Park testing.

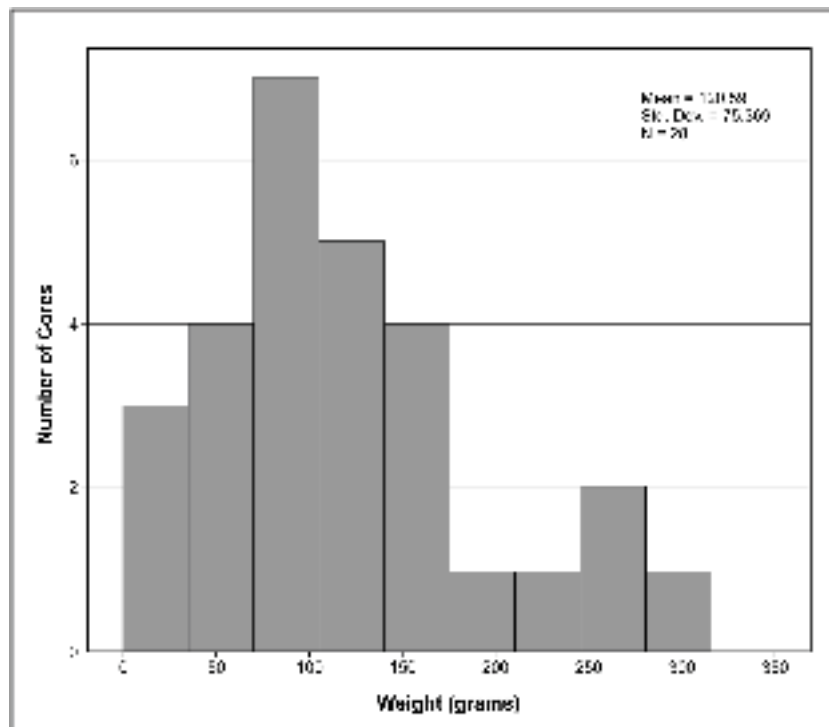

Figure 10-18. Weight (grams) of cores recovered from San Pedro Park testing.

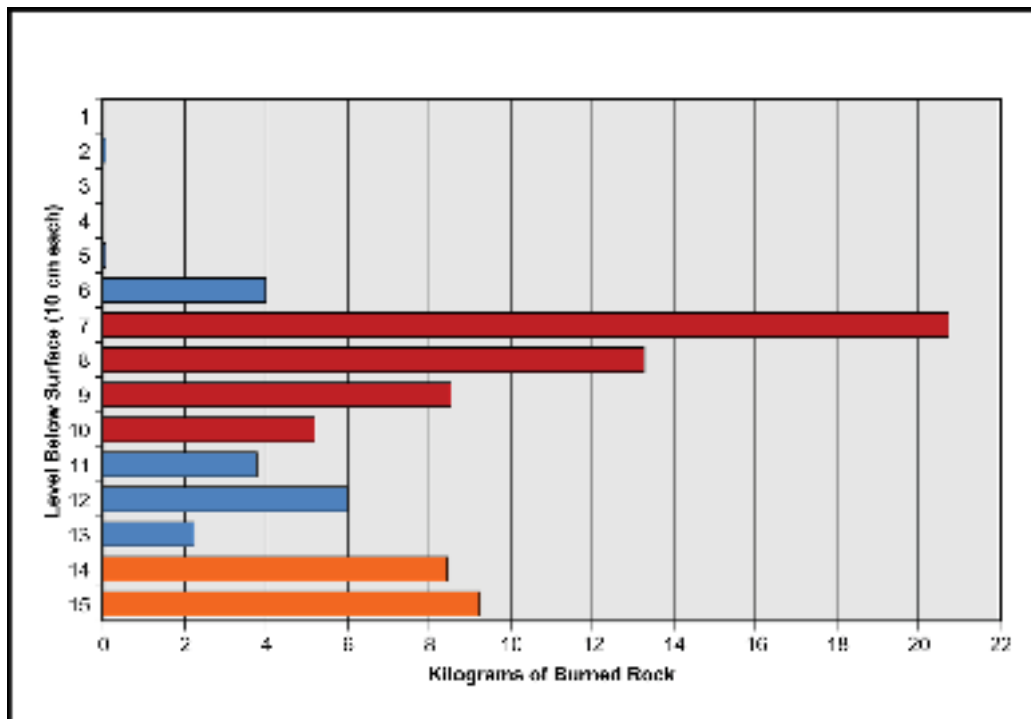

Figure 10-19. Burned rock weight (kg) by level for Test Unit 4.

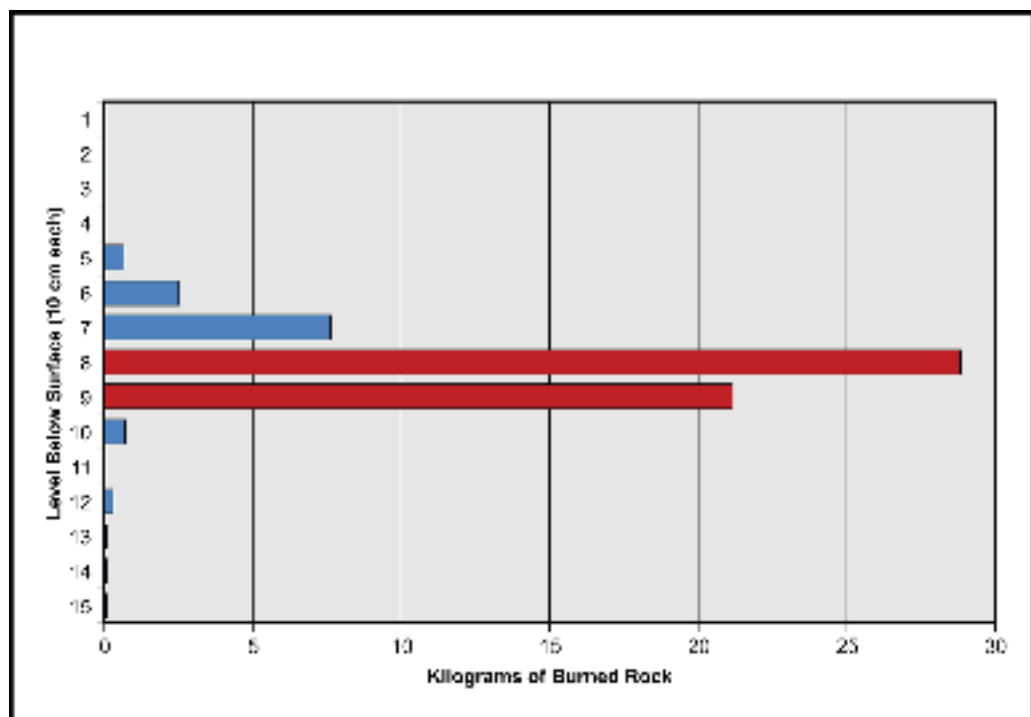

Figure 10-20. Burned rock weight (kg) by level for Test Unit 1.

The concentration of rock defined as Feature 1 in TU 1 was the primary reason for the excavation of TUs 5, 6, and 10. These units were designed to determine the extent of that distribution. TU 10, located roughly 2 m north and 3 m east of TU 1, produced a single peak in rock weight, though smaller and slightly higher than that in TU 1 (Figure 10-21). TUs 5 and 6, located roughly 9 m to the east and west of TU 1, produced lower quantities of rock with peaks at Levels 6-8 (Figures 10-22 and 10-23). Given these distributions, it is likely that Feature 1 in TU 1 is a discrete occurrence, below a general layer of burned rock. However, additional features may certainly be present in this area, especially given the relatively high concentration of rock in TU 10.

TU 2 had small quantities of burned rock present, with 1.39 kg recovered. Most of this (0.94 kg.) is within Level 3, the area of higher debitage and a Late Prehistoric point. TUs 3 and 7 have minimal rock present, with TUs 8 and 9 having a small quantity, most of which is in the middle and bottom of the units. The only other moderate quantity of rock (2.63 kg) was recovered from TU 13 in the Map 5 area, with the distribution shown in Figure 10-24. Curiously, all levels have some rock present, and while there is a small peak at Level 5, there are multiple smaller peaks present. The TU 13 distribution likely reflects a variety of disturbances, with no clearly intact levels present.

Summary

A variety of artifacts were recovered from the shovel testing and test excavations. In addition to the major classes discussed in this chapter, small amounts of charcoal, burned clay, mussel shell, and a variety of snail shell were collected. Modern construction related materials, including brick and tile fragments, asphalt and slag deposits, concrete, wood, and plastic, were also collected. The distribution of the major classes of material, summarized above, suggests that the upper 40-50 cm across most of the park have significant levels of disturbance. The possible exceptions to this are the Map 3 area (TU 2), with a possible Late Prehistoric, Proto-historic, and/or Colonial Period component, and the Map 1 area (TU 7), with some possibly late nineteenth- or early twentieth-century material mixed. In addition, the Map 5 area (TU 13), located in the softball outfield, clearly has a different pattern of deposition, as do the materials deposited in the Map 7 area, probably as secondary fill, in TUs 8 and 9. The abrupt start of distributions with what appears to be Late Archaic material, often capped by relatively clean fill, gravel, or material reminiscent of road base, in several areas clearly documents this disturbance. Nevertheless, several areas of the site appear to have intact deposits below this level, with both high artifact and ecofact variety and high density. Foremost among these is the area associated with TU 4 and associated trenches.

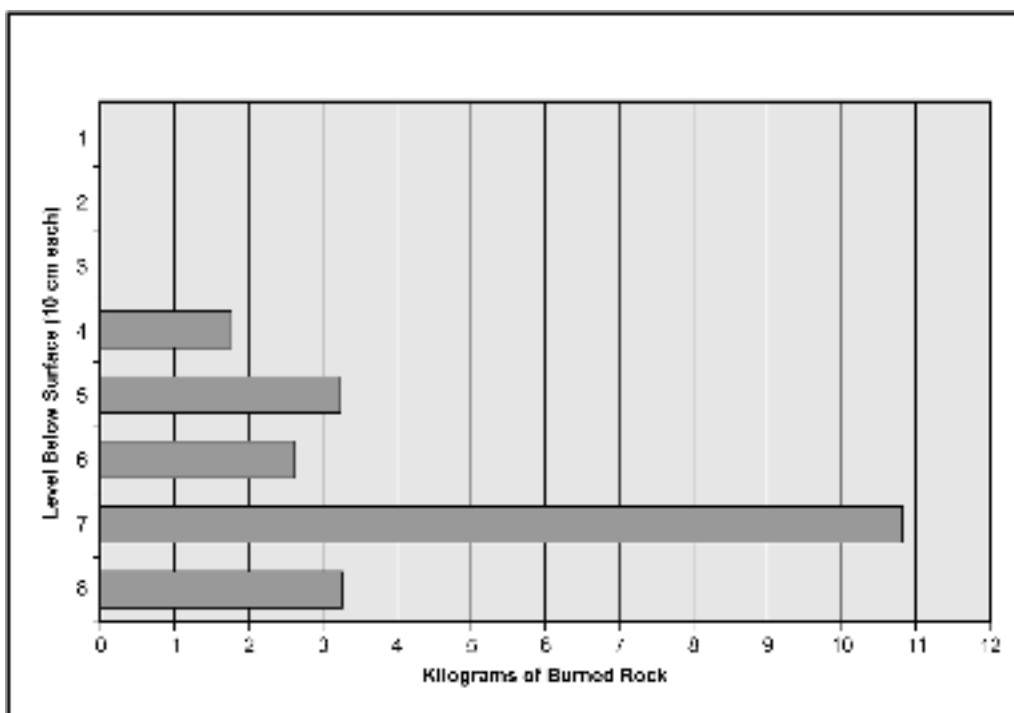

Figure 10-21. Burned rock weight (kg) by level for Test Unit 10.

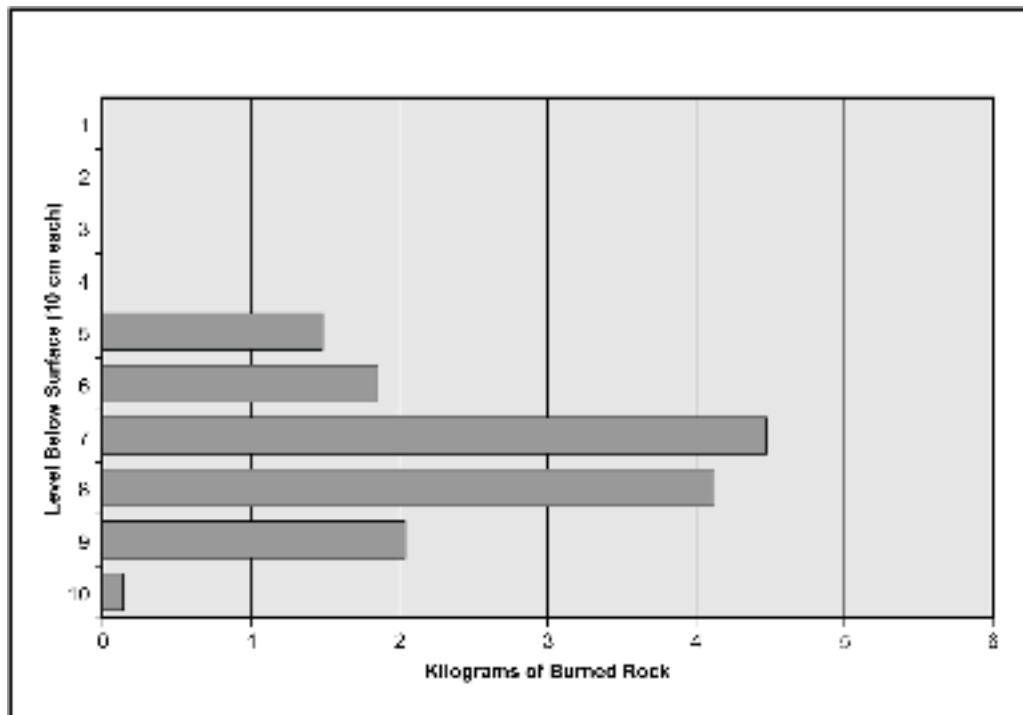

Figure 10-22. Burned rock weight (kg) by level for Test Unit 5.

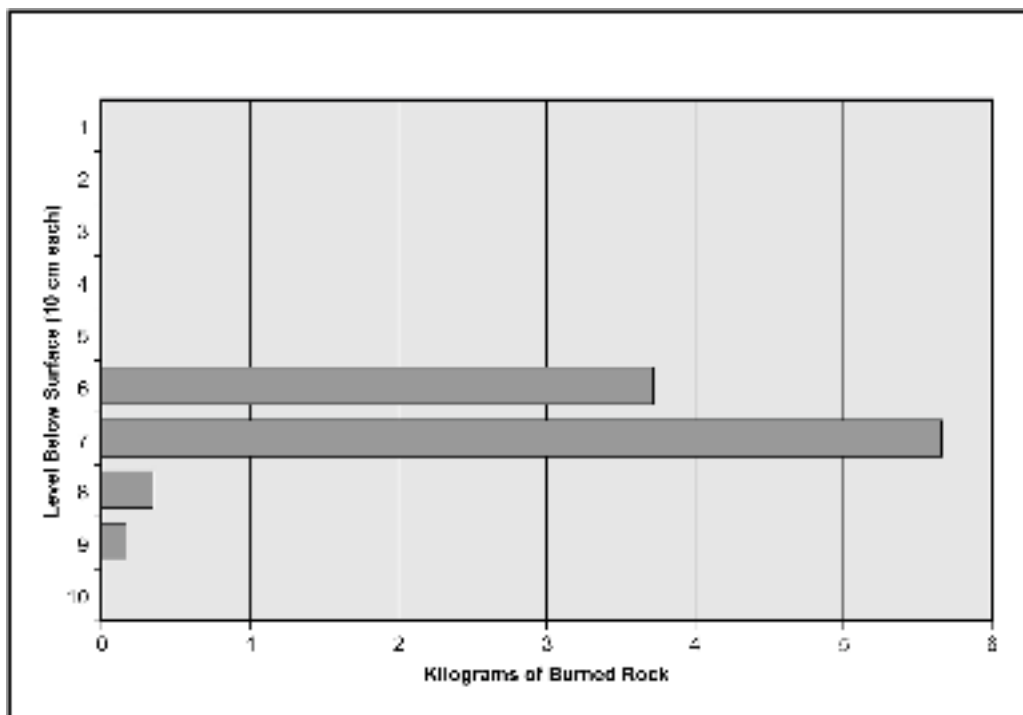

Figure 10-23. Burned rock weight (kg) by level for Test Unit 6.

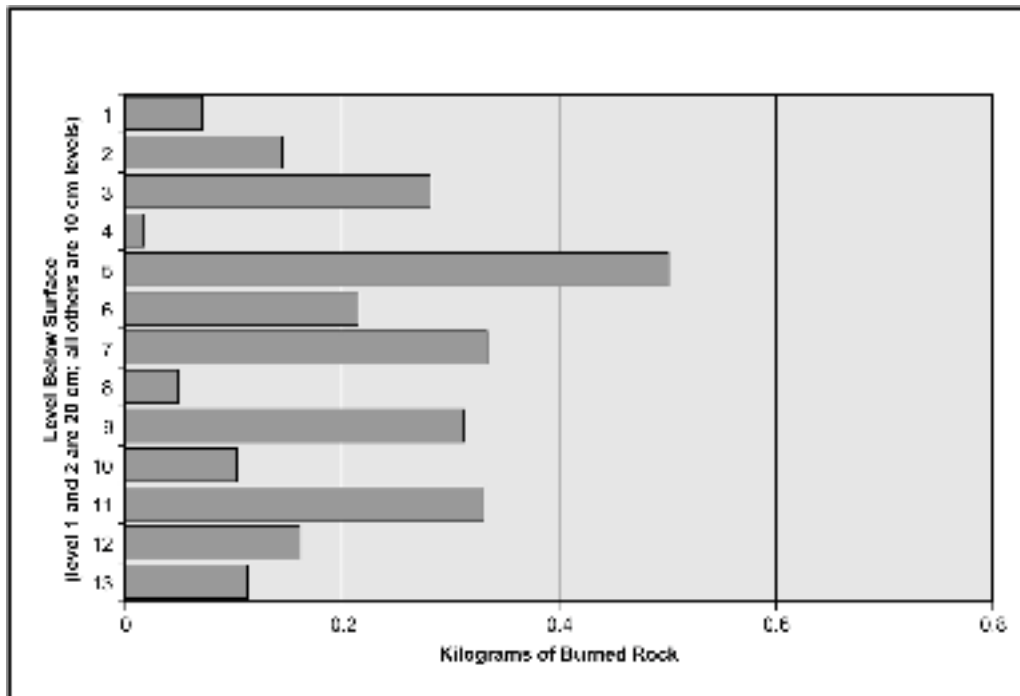

Figure 10-24. Burned rock weight (kg) by level for Test Unit 13.

Chapter 11: Magnetic Susceptibility Values and the Integrity of the Deposits

Raymond Mauldin and Stephen Smith

The summaries of artifact distributions combined with reviews of previous research and park activities highlight several areas within the park that potentially have different use histories. These different histories have implications for shift in the integrity of the deposits in these various park areas. This chapter focuses on patterning in Magnetic Soil Susceptibility (MSS) values in the San Pedro Park deposits for three areas that seem to have potential for intact, buried deposits of different ages. MSS profiled data can provide additional, and in some sense independent, data on use history and stability of sediment that has implications for the integrity of archaeological deposits.

For all test units except TU 13, soil samples were collected from unit profiles following excavation. In most cases, samples were collected at 5-cm increments, though for some profiles increments were at 10-cm. The MSS value for a given profile is primarily a function of the concentration and grain size of ferrimagnetic and ferromagnetic minerals. These minerals, such as iron, magnetite, maghemite, and

other iron oxides (Dearing 1999), are common by-products of pedogenic and anthropogenic processes. MSS values in a sample can increase or decrease in sediment as a function of several factors. Activities that can dramatically increase sample values include cooking fires or the deposition of organic debris on a surface (see Bellomo 1983; Crowther 2003; Mauldin and Figueroa 2006; McClean and Kean 1993). Geomorphic and pedogenic processes, such as organic decay and microbial activity, can also increase values (see Reynolds and King 1995; Singer and Fine 1989).

Interpretations of MSS values for a given profile are complicated, and the same MSS values could potentially result from several different processes. Yet, the results can provide critical data in many cases. Figure 11-1 presents a typical sediment profile. A common interpretation of a pattern such as this would be the gradual aggradation of sediment up through roughly 70 cm. Stability at that point would result in the accumulation of organics on that surface, and this would produce higher MSS values. As sediments again

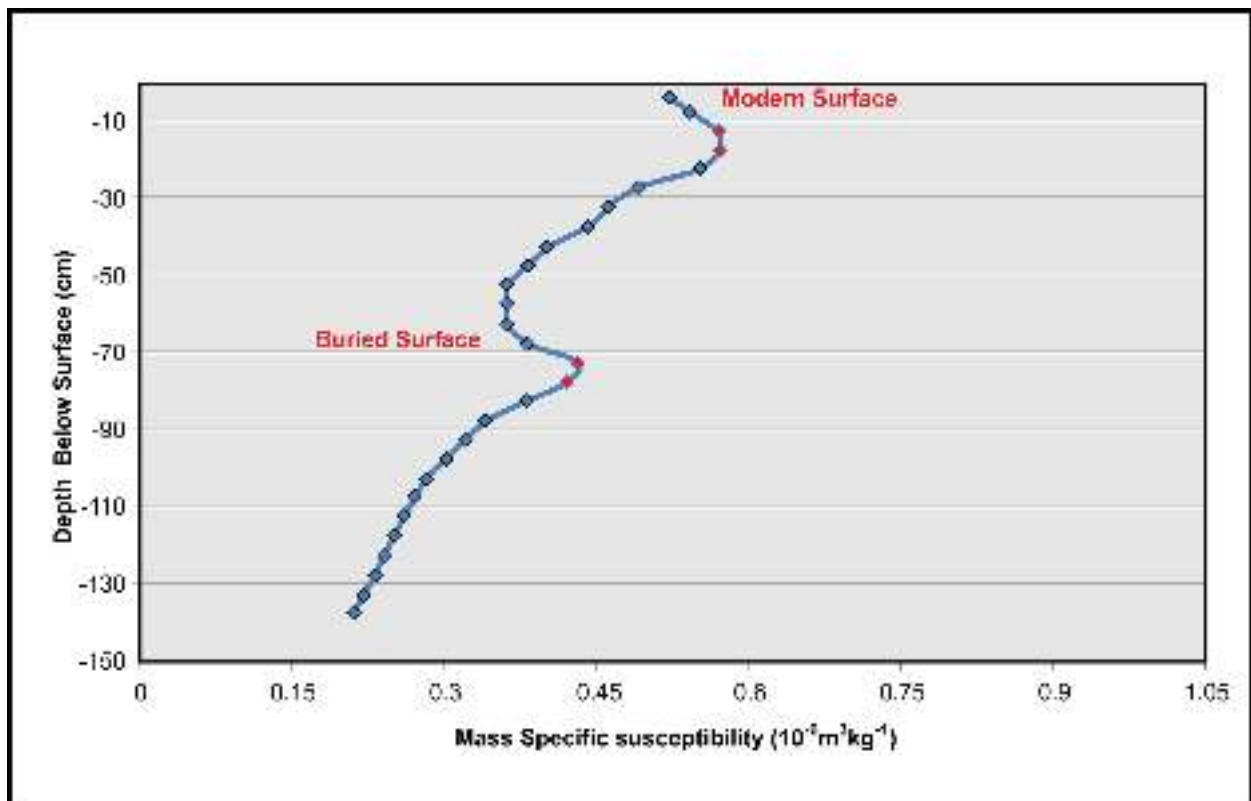

Figure 11-1. A hypothetical MSS profile showing a buried surface.

were deposited, the surface would increase and that higher, organically enhanced point would be buried. At the top of the profile, at a modern surface, higher values may again be present, such as is shown in the Figure 11-1 example. The use of a given, stable surface for an extended period by humans, such as might occur when that 70 cm point in the figure was on the surface, should produce high susceptibility values on that surface, further exacerbating the high values associated with natural vegetation decay. When that surface is buried, microbial activity in the higher organic deposits may also enhance the susceptibility values. Conversely, factors, such as bioturbation or erosion, that disrupt sediment aggradation, buried sediment stability, or surface stability will produce a uniform distribution or a truncated pattern of MSS values. While MSS patterns are complex (e.g., Liu et al. 2001) and not always easily interpreted, MSS values can provide an additional measure of sediment stability that can be used to assess aspects of archaeological integrity in specific cases.

For this project, all MSS samples were processed at the CAR laboratory following established procedures. Samples were initially dried, sized through non-metallic screens to remove larger gravel, and then lightly crushed. Sediment was placed into small plastic pots and weighed, and then magnetic

potential was assessed with a Barrington MSS susceptibility meter. Values were corrected for sample mass following procedures outlined by Dearing (1999).

Figure 11-2 presents the MSS pattern for sediments collected in 5-cm increments from the face of TU 4 in the Map 4 area. The strength of the susceptibility is plotted on the X-axis, while the depth of the sample is plotted on the Y-axis. At 120 cmbs, the susceptibility values in the profile shift dramatically, with a roughly 10-fold increase over 45-50 cmbs. At 45 cmbs, the values fall even more dramatically, with a decline back to the original range (ca. $0.1 \times 10^{-6} \text{m}^3 \text{kg}^{-1}$) in 10 cm. From that point, the values increase slowly, with a small spike at 17.5 cmbs, a decline, and then an increase at the surface.

The level and speed of enhancement, as well as the level and speed of the decline for this MSS curve, are unusual. While sudden increases and decreases have been recorded at other sites, these are often a function of high values in one or two samples and usually reflect some sort of contamination or unique soil characteristics. For example, high values in deposits in some areas (e.g., Sandy Mantel deposits) are often associated with the presence of small iron concretions in these sediments (see Mauldin 2003b). The presence of rusted metal

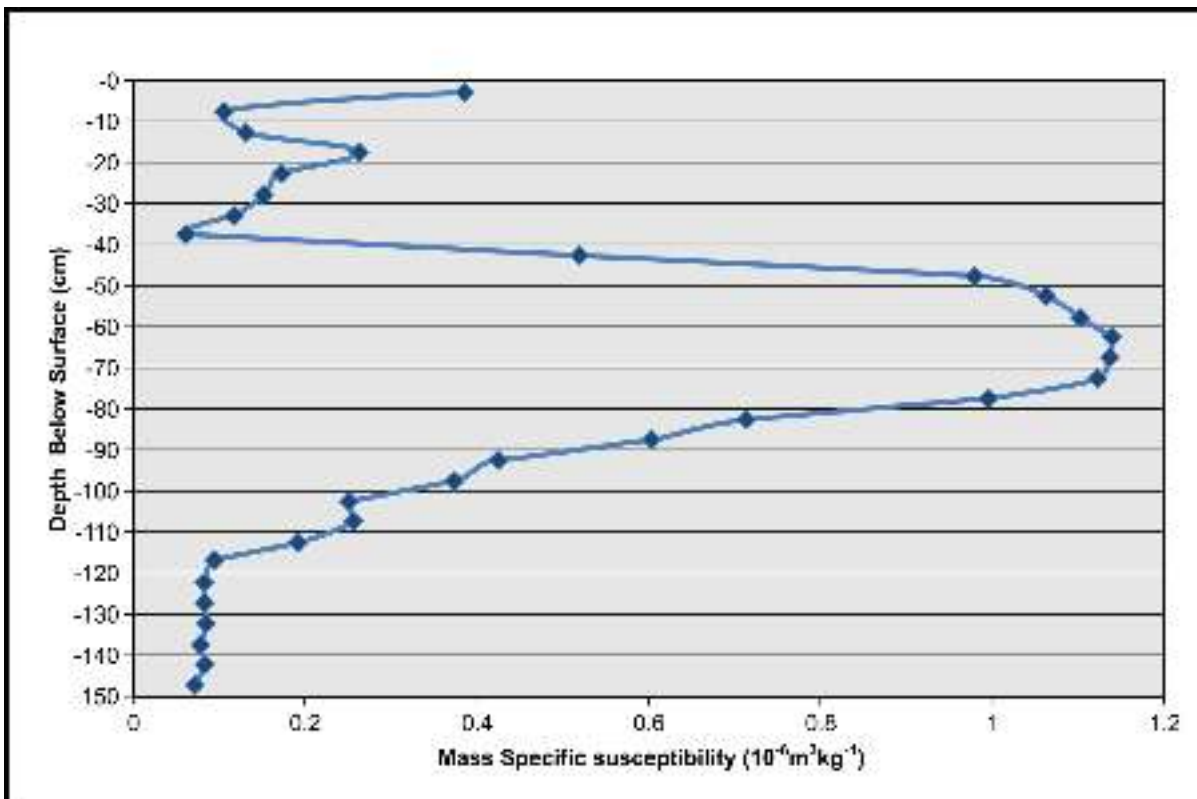

Figure 11-2. MSS values for profile in Test Unit 4.

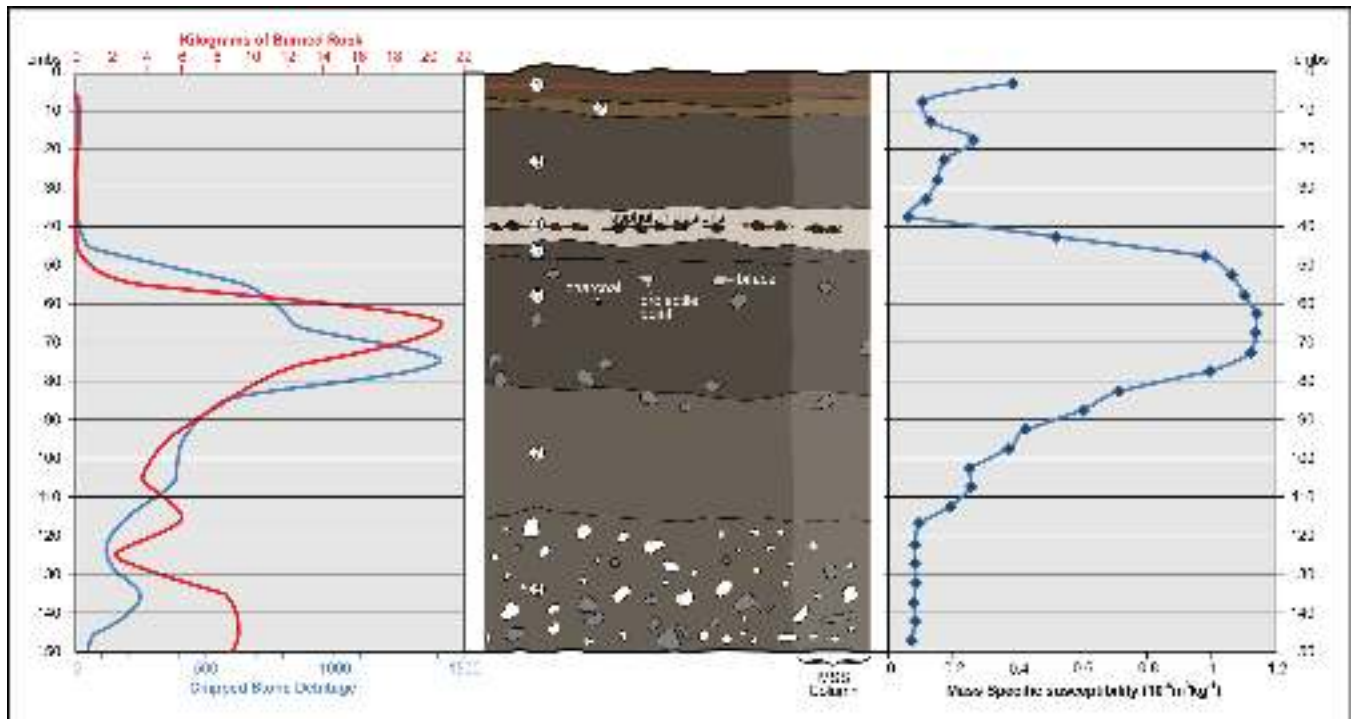

Figure 11-3. Test Unit 4 artifacts (left), profile (middle), and MSS values (right) by depth.

in a given level can also result in high fluctuations in series. However, the rapid increase in MSS values in Figure 11-2, the sustained high values present for multiple levels, and the sudden reversals are unusual for most MSS sequences.

Figure 11-3 was constructed to explore this pattern further. This figure places the Figure 11-2 pattern in the middle of two other panels. The panel on the left plots the weight of burned rock (red line) and the number of chipped stone debitage (blue line), while the panel in the middle is the profile of this unit presented earlier (Figure 8-9). There is a clear relationship between the quantities of artifacts, the MSS values, and the profile descriptions. These relationships are especially apparent in the middle strata (Levels 4-7; 35-115 cmbs). Increases and decreases in numbers of chipped stone and burned rock weight closely match the MSS values and are broadly correlated with shifts in the profile. In this particular profile, it was clear from the excavation that the Level 4 material was intrusive and that the upper deposits had probably been removed. This would essentially truncate the distribution at 45 cmbs. The MSS pattern suggests that deposits below 45 cm are likely to maintain some integrity in spite of some mixing of deposits as indicated by a small amount of modern material at depth and a Late Prehistoric charcoal date in a Late Archaic context (Appendix A). The MSS pattern seen here adds little to the understanding of the overall deposit, other than to bolster the original interpretation. However, the pattern of rapid truncation seen here is repeated at several other locations and is discussed below.

Figures 11-4 and 11-5 show MSS patterns for TUs 5 and 10 in Map 6 area. The patterns are similar for TUs 1 and 6 in this area (not shown). While the details differ slightly, all show high values for roughly 40 cm of deposits in the middle of the profiles and a rapid drop off within 30-40 cm of the current surface. These patterns, like those for TU 4 (Figure 11-3), suggest stability in the depositional sequence below 30-40 cm. In addition, they suggest that the upper portions of the deposits are truncated. This is especially clear for TU 10 (Figure 11-5), which has a rapid, dramatic drop.

Figure 11-6 shows a very different pattern for TU 2, located in the Map 3 area. Overall, the level of intensity, shown on the X-axis, is much lower than what has been seen in the previously discussed areas. Nevertheless, below the modern surface, MSS values do show a peak at 25 cm. It is at this depth that there is also a peak in artifacts and a Late Prehistoric projectile point. A Native American ceramic was recovered from the second level, along with the remains of bison that probably dates to the Proto-historic or Colonial Period. Below the peak, a relatively stable pattern is indicated. There is no dramatic truncation of the upper deposits, though the low values at 15 cmbs might suggest an intrusion, perhaps related to a thin gravel deposit (see Figure 8-7).

Figure 11-7, which presents the pattern seen in TU 7 in the Map 1 area, shows yet another pattern. The intensity is slightly higher overall than the Figure 11-6 plot, suggesting

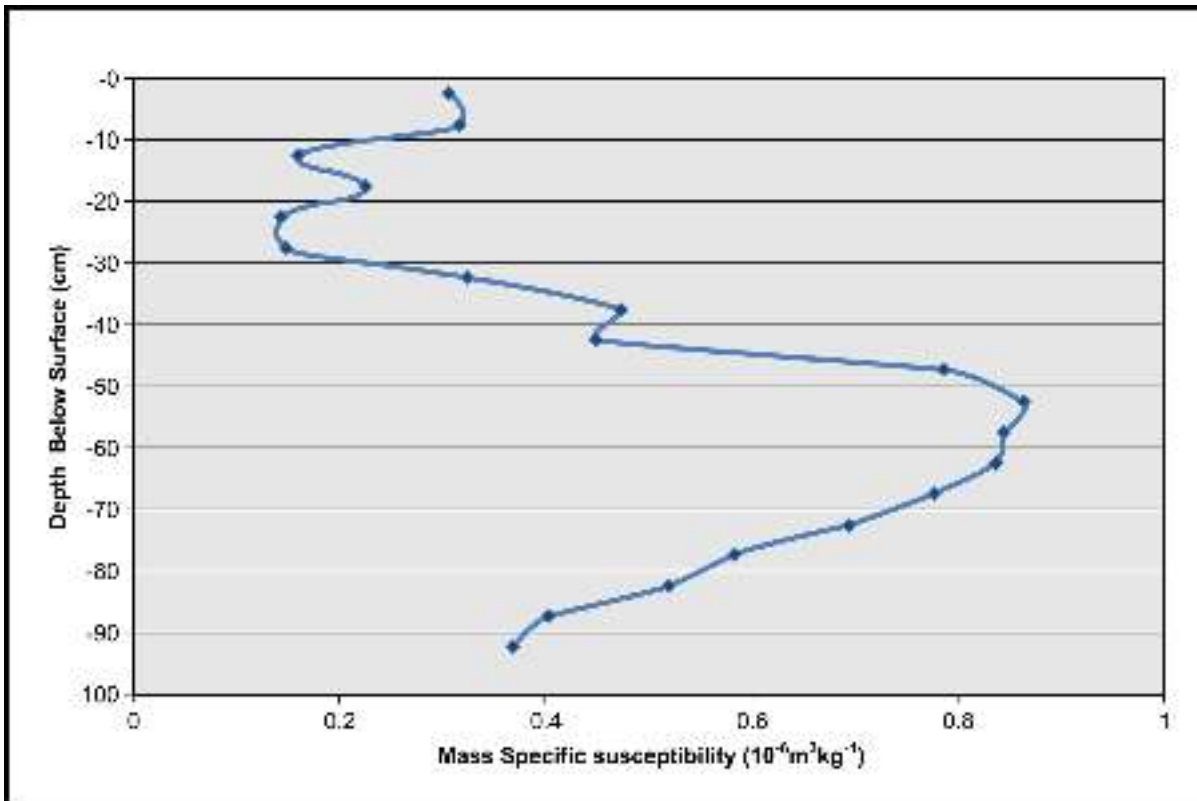

Figure 11-4. MSS values for profile in Test Unit 5.

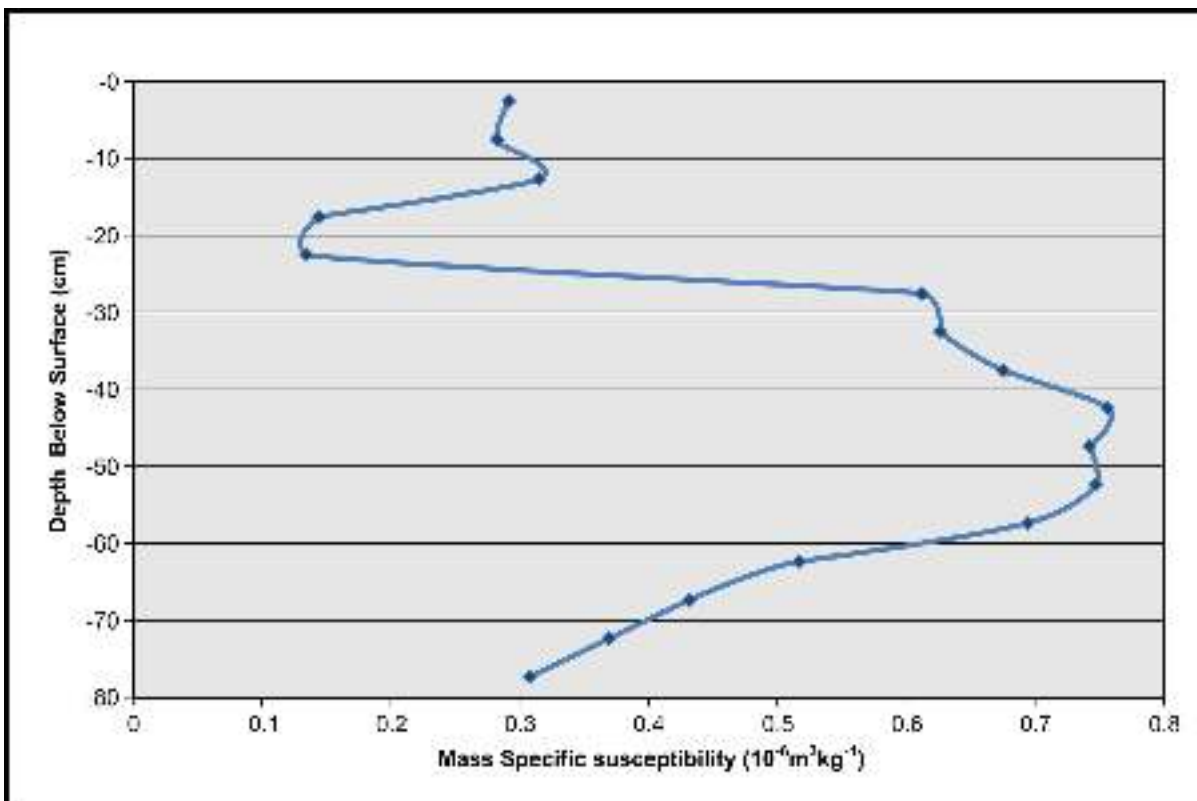

Figure 11-5. MSS values for profile in Test Unit 10.

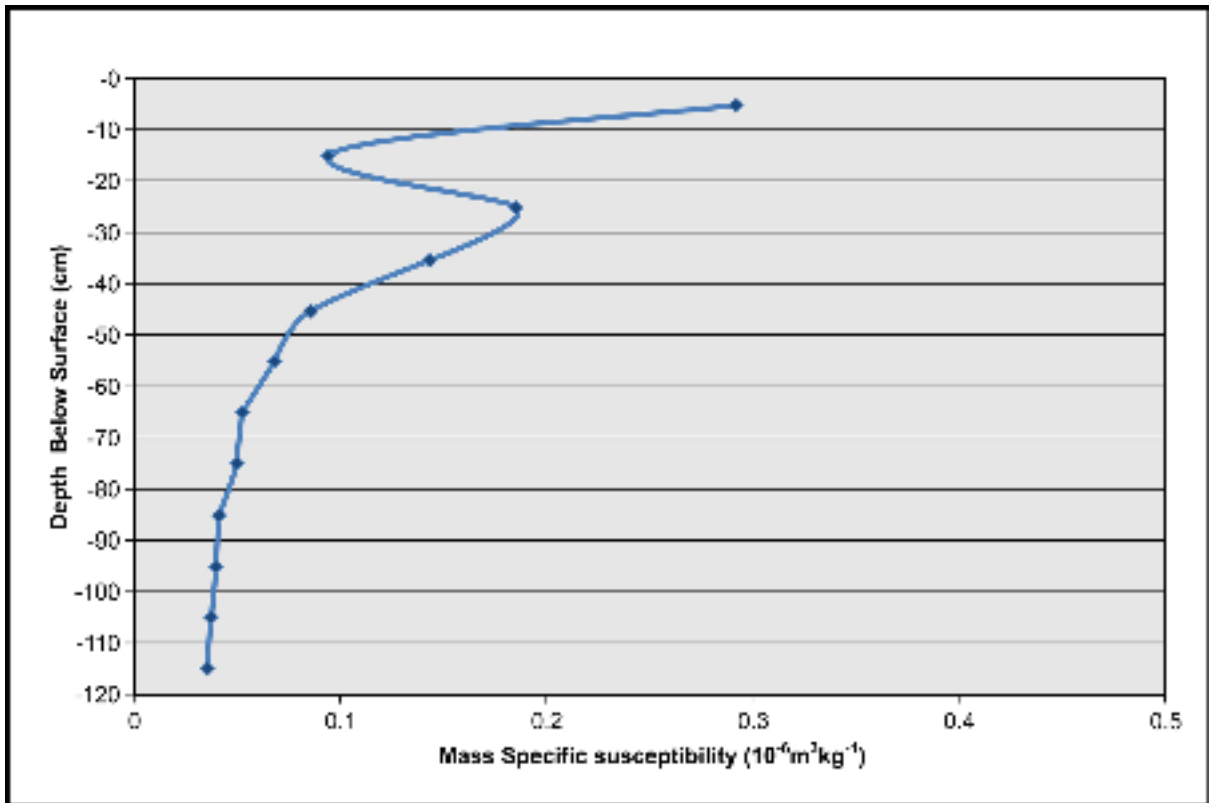

Figure 11-6. MSS values for profile in Test Unit 2.

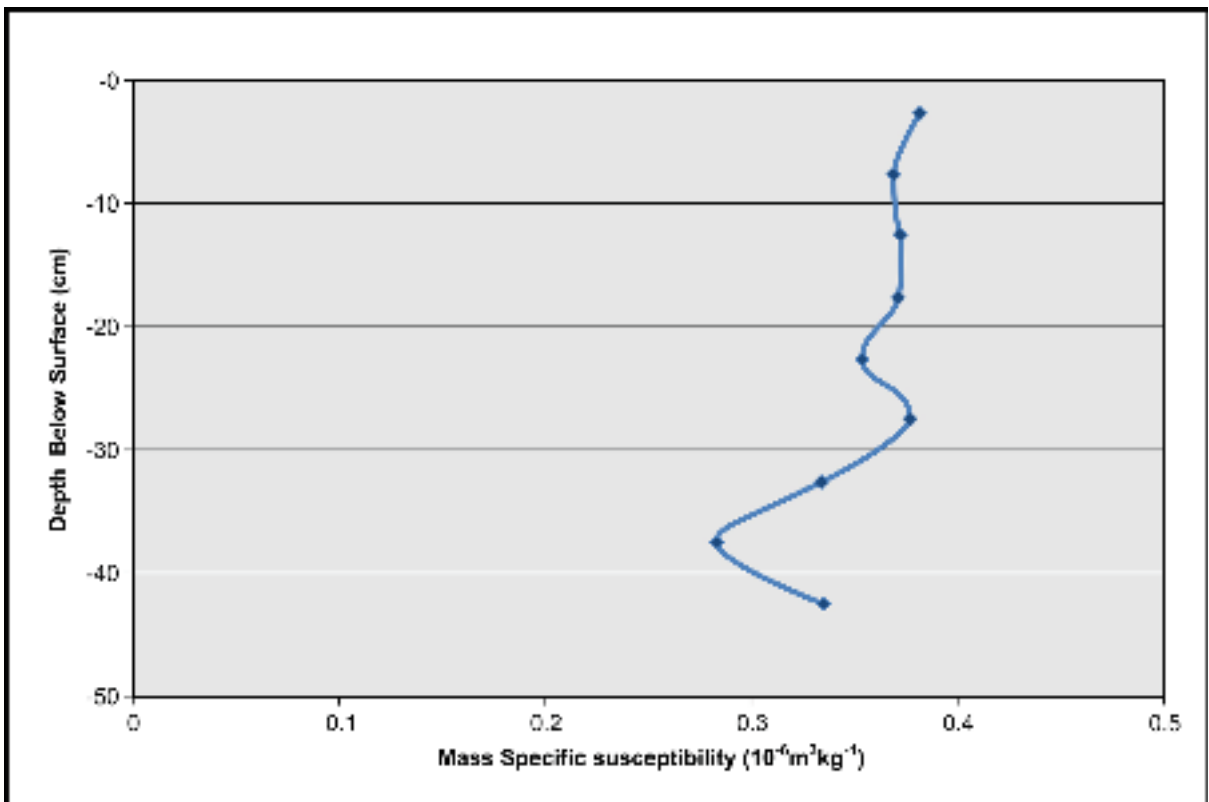

Figure 11-7. MSS values for profile in Test Unit 7.

that more organic material may be in the sediment within this area. No major peaks are present, though there is a small shift at 27.5 cmbs. This pattern is one that suggests some level of sedimenturbation, with little overall stability.

Summary

The Magnetic Susceptibility values discussed here suggest that the Map 4 area, which contains a high density of archaeological material, probably represents a stable, gradual accumulation of organics over a long period. The sudden shift at the top of that profile is most likely related to the removal of sediment and the deposition of new material that caps the surface. This is probably associated with the 1899 renovations to the park, though later disturbances, such as

work in the 1930s, are also a possibility. A similar, though less intense, occupation is probably represented in the Map 6 area. In TUs 1, 5, 6, and 10 there is evidence for a gradual accumulation of organics deeper in the profiles, with a sudden truncation near the surface. There is minimal stability in the area of Map 1, TU 7, an area that may be near a historic midden deposit identified originally by Zapata and Meissner (2003:20-21). Finally, the MSS patterns in Map 3 area, TU 2, provides evidence for some stability. While there is no evidence for deep accumulations of organics, the upper levels are likely to be stable. These are associated with Late Prehistoric, Proto-historic, and/or Colonial Period use of San Pedro Park. The lack of truncation suggests that this portion of the park was not extensively altered by earlier renovations, and this area clearly has the highest potential for intact colonial deposits.

Chapter 12: Conclusions and Recommendations

Raymond Mauldin

The research goals of the investigations were 1) to identify any proto-historic and colonial deposits, including evidence of the first *acequia* in the region, an associated dam, and any evidence associated with the presidio and villa founded in 1718 and 2) to identify and investigate areas of intact prehistoric cultural deposits. In light of these goals, CAR staff used a combination of reviews of previous archaeological work, historic maps, and newspaper accounts to try to identify areas that were likely to reveal evidence of both the proto-historic and colonial deposits, areas of San Pedro Park that had not been systematically investigated, and areas that had been extensively disturbed.

Based on historic map overlays, there is evidence that the Colonial Period dam probably was destroyed by earlier construction. Shovel testing suggests extensive disturbance in this area. The suggestion that the dam was destroyed was also the conclusion reached by Houk based on earlier work (Houk 1999). Overlays suggest the possibility that some areas of the head gate may still be intact but that it is likely to have been destroyed as well. What probably does remain is a section of the San Pedro *Acequia*. Unfortunately, documenting that section may be difficult, primarily because a variety of utility lines are located in this portion of the park. To do so would likely require hand excavations and would potentially disrupt or limit park activities to insure the safety of excavators. CAR excavations, well to the west of where it is now thought the *acequia* is, did hit a north/south trending channel that is filled with a mix of modern and prehistoric material. This is unlikely to be the remnants of the *acequia*, but it does demonstrate that this portion of the park has a complex construction history that is not understood at present. Additional, systematic work in this area would help clarify the nature of these various channels.

CAR staff found no direct evidence that could be tied to the 1718 colonial presidio or villa. Results from the excavations suggest that in most areas of the park, any proto-historic or colonial material that was present is likely to have been extensively disturbed. Much of that disturbance would have occurred in association with park renovations in 1899 that removed large quantities of sediment, and likely associated colonial, proto-historic, and earlier prehistoric material, from the upper levels of the park. This event is probably reflected in several of the project's excavations, but it is most clearly shown in TU 4 as a hard packed, crushed limestone-dominated deposit at about 50 cm below the modern surface. Additional work throughout the twentieth century, including

several upgrades to facilities and infrastructure within San Pedro Park, has further degraded the historic and prehistoric resources. Nevertheless, evidence based on artifact frequency and types, magnetic susceptibility values, and radiocarbon dates suggests that three areas of the site have intact deposits, including deposits related to the proto-historic and colonial use of the area. These are the area around TUs 1, 5, 6, and 10 (Map 6 area), TU 2 (Map 3 area), and TU 4 (Map 4 area).

The four units excavated in the Map 6 area defined a single burned rock feature (Feature 1) along with a low-density background scatter of burned rock. Chipped stone debitage, tools, and cores, bone, mussel shell, several Native American ceramics, and historic and modern material were recovered from these units. The upper 50-60 cm of deposits across these units is mixed, with portions capped by a sterile, limestone- and sand-dominated fill that may have served, in some cases, as an old road base. Below that fill, excavation uncovered projectile points and other artifacts, which suggest a Late Prehistoric and Late Archaic use. Three radiocarbon dates were ran from TU 5. One of these (CAR 346), from near the bottom of the disturbed zone at 50-60 cmbs, was on the bone collagen from a very large mammal consistent with bison. That date yielded a corrected, calibrated date range that is most likely to fall in the Proto-historic or Colonial Period.

While patterns in counts and artifacts from excavations in the second area, TU 2, suggested some mixing in the upper 20 cm of deposits, a single Native American ceramic was recovered. A radiocarbon date (CAR 344) on collagen from bison bone recovered in that same level produced a corrected, calibrated date almost identical to CAR 346, again suggesting a Proto-historic or Colonial Period use. Below that date, CAR staff recovered a Late Prehistoric (Edwards) point along with substantial debitage. The deposits in this area, then, are likely to relate to several different periods, from the Late Prehistoric through the Colonial Period. The potential that intact Late Prehistoric and potentially Proto-historic and Colonial Period materials are present in at least one and possibly two areas is encouraging. In addition, note that while only four radiocarbon dates on faunal material were obtained, half of these have dates that fall with the Proto-historic or Colonial Period. These data suggest that other areas within the park likely have intact Proto-historic or Colonial Period deposits.

The final area with significant information potential is centered on TU 4. This unit had a mixed, low-density pattern of artifacts down to 50-60 cmbs. The unit then produced an

extremely high density of debitage and burned rock, with several points and other lithic tools, and high density of bone. Though there is rodent disturbance and some movement of material, several data sets suggest this deposit is primarily Late Archaic in age, with Frio, Montell, Marcos, Castroville, and Pedernales points recovered. A radiocarbon date from a small piece of wood charcoal produced a calibrated, corrected date range that was Late Prehistoric (Beta 390003). The dated piece charcoal is likely to be out of context, as there is rodent disturbance in some of these deposits. Finally, note that this area may have material that dates to the Early Archaic as a possible Guadalupe tool was recovered from Level 13.

The densities of burned rock and debitage from TU 4 rivals any deposit in Central Texas. Based on limited trenching, this deposit extends for at least 15 m east-west, and an unknown distance north-south. Using the minimum size of 15-x-10 m, for example, and using the TU 4 density of chipped stone recovery, this area would contain a minimum of 600,000 pieces of chipped stone. Note that this figure does not include the Late Prehistoric, Proto-historic, and possibly Colonial Period material, likely removed from the area by the 1899 renovation. One possibility, given these estimated densities, is that unlike the Map 6 area, which has an isolated feature and moderate density, the TU 4 location may represent a classic trash midden deposit, rather than any sort of living surface. As outlined previously, Orchard noted a large midden on the surface in the 1930s but placed the location in the northwestern portion of the park (Orchard and Campbell 1960). That second midden, based on the recovery of a variety of ceramics by Orchard, is probably late in time. One possibility is that this second midden may have been the upper component of the TU 4 midden, removed and spread in the northwestern portion of the park as fill in 1899. It could also simply represent an additional midden deposit. Regardless of which scenario is correct, the presence of these types of features clearly suggests the use of the park as a habitation site with some degree of permanence. Formal middens for trash disposal suggest regular site maintenance. This type of feature, especially of this magnitude, is not common on hunter-gatherer occupations. This would also fit with the reference to burials at this site. While no human bone was recovered during this project, the historic accounts of caves and burials summarized in Chapter 4 clearly suggest that burials were present. If the Map 4 area location is a formal trash midden, this has implications for questions concerning land use, mobility, and possibly the development of territoriality. These deposits, along with those recovered in the Map 6 and Map 3 areas, clearly have the potential to add significantly to the understanding of several prehistoric periods, as well as the poorly documented Proto-historic, and Colonial Period in the Central Texas region.

Recommendations

As discussed previously, other than the perimeter hike and bike trail, no specific impacts were identified prior to project planning, though revisions to the original 1994 Master Plan (RVKB 1994) have been proposed (Beaty Palmer 2013). Rather than address specific impacts, CAR staff built upon the earlier work of Meissner (2000c; Zapata and Meissner 2003) who developed a series of impact zones. These zones were briefly discussed in Chapter 5 and are reproduced here as Figure 12-1. Zone 1 covered areas of cultural deposits that were thought to have integrity. Zone 2 consisted of areas with no information in which testing was recommended. Zone 3 were areas known to have been impacted down to 30 cmbs. Zone 4 included areas disturbed down to 183 cm. Zone 5 areas had no potential for intact deposits.

The Figure 12-1 distribution was, as noted previously, based on limited testing. Figure 12-2 presents a density plot of modern material recovered in the upper 30 cm of the more extensive shovel testing, presented earlier in Chapter 7. While it was not possible to transform all artifact categories into comparable groups, Figure 12-3 uses the same procedures to plot modern data in the upper 30 cm of shovel tests from selected areas of two earlier projects (Houk 1999; Zapata and Meissner 2003). When these two distributions in the figures are considered in the context of current buildings and facilities, it is clear that there are few areas of the park that have not had some disturbance down to at least 30 cm.

The low frequency disturbance across much of the upper 30 cm is consistent with what is known of historic impacts, as is consistent with what was observed in most of the test excavations. Using those data, as well as information from Meissner's early impact areas (Figure 12-1) and the 1899 Trueheart Map presented previously, CAR proposes three broad management areas (Figure 12-4). The figure includes historic features and contours, as well as modern features. Whenever possible, Meissner's original distinctions have been maintained.

Management Area 3, shown in yellow, encompasses Meissner's Zones 4 and 5, with small additions. While architectural concerns are clearly present, it seems highly unlikely that any extensive ground disturbing activities will occur in these areas, and in most of the areas, there is minimal potential that intact deposits will be recovered. While CAR staff is in the process of comparing modern and prehistoric contours to clearly identify changes, it is likely that these areas have been extensively altered. Consequently, CAR would suggest that any ground disturbing activities within 1.5 m of the surface be allowed to proceed.

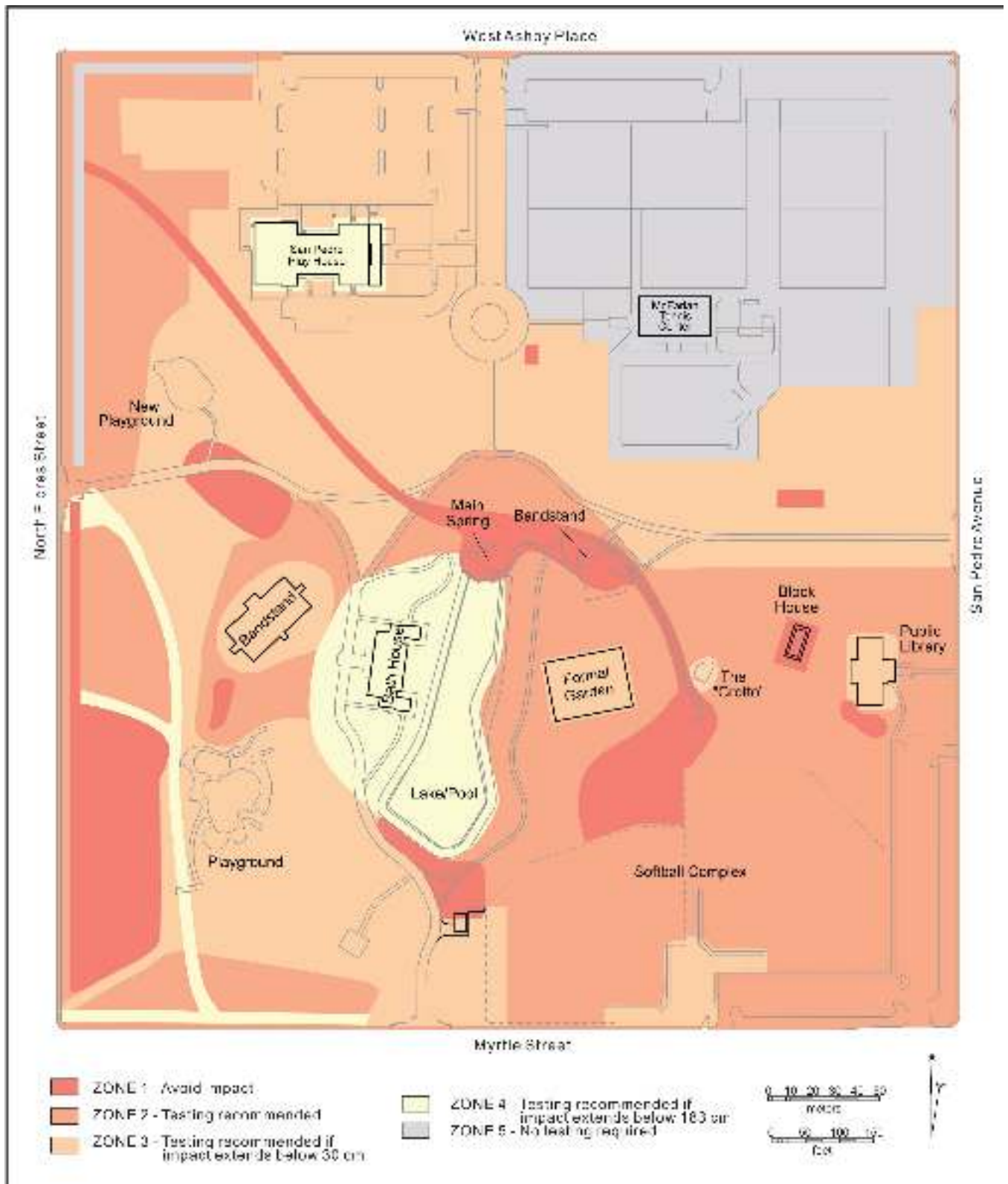

Figure 12-1. Impact Zones identified in previous work (Zapata and Meissner 2003).

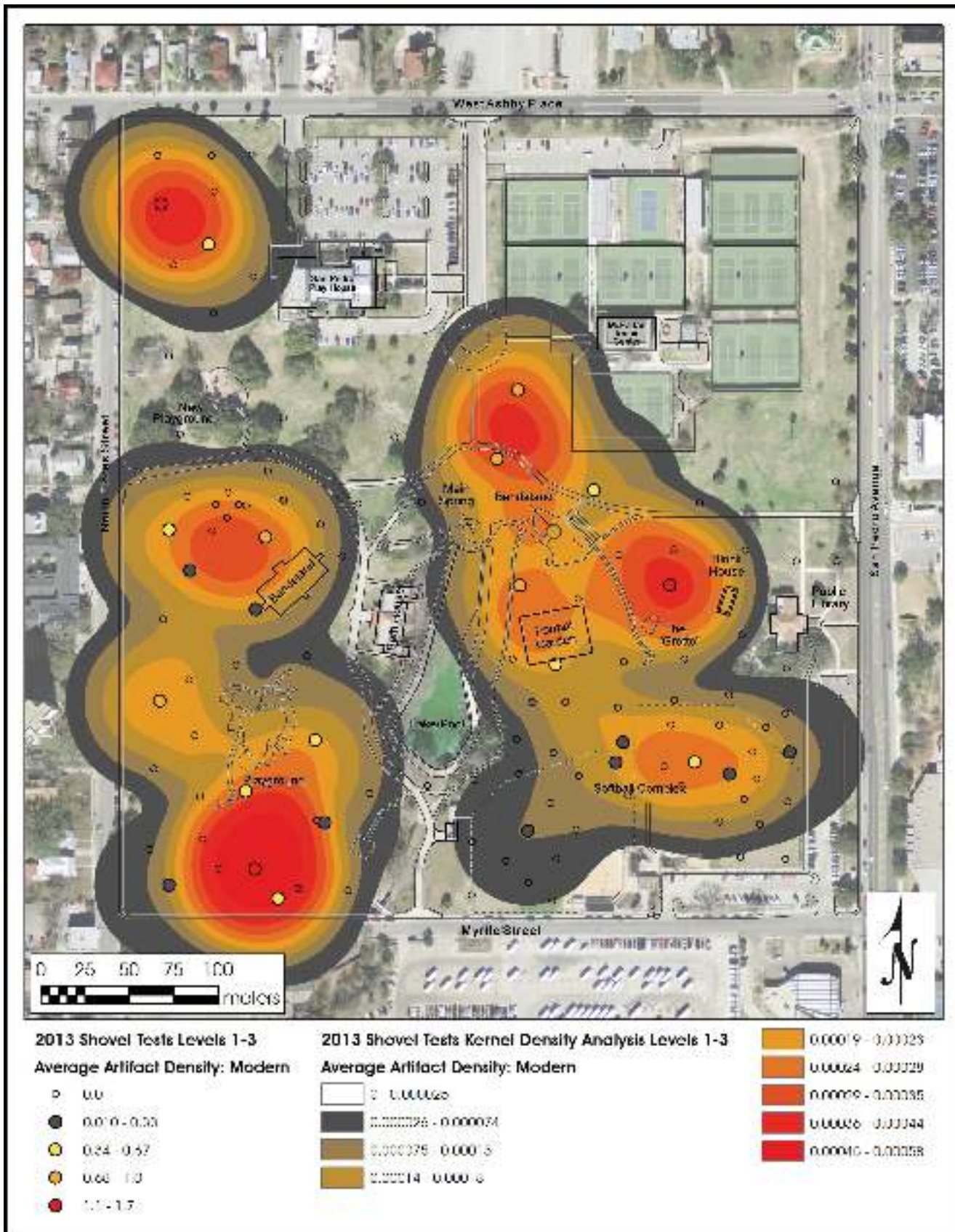

Figure 12-2. Kernel density plot of modern artifacts in shovel tests, Levels 1-3 (see Chapter 7).

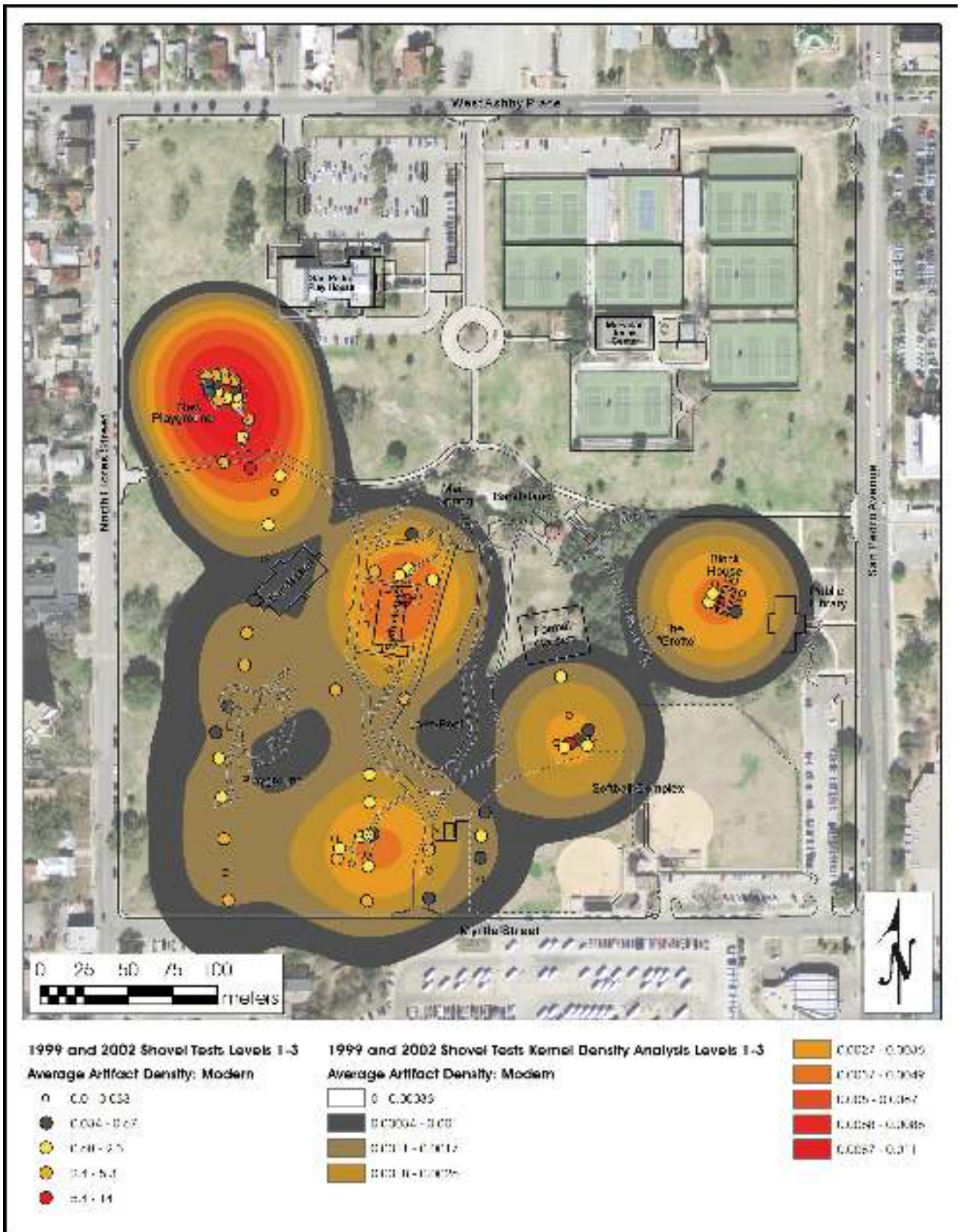

Figure 12-3. Kernel density plots of modern material in shovel tests, Levels 1-3, from Zapata and Meissner (2003) and Houk (1999).

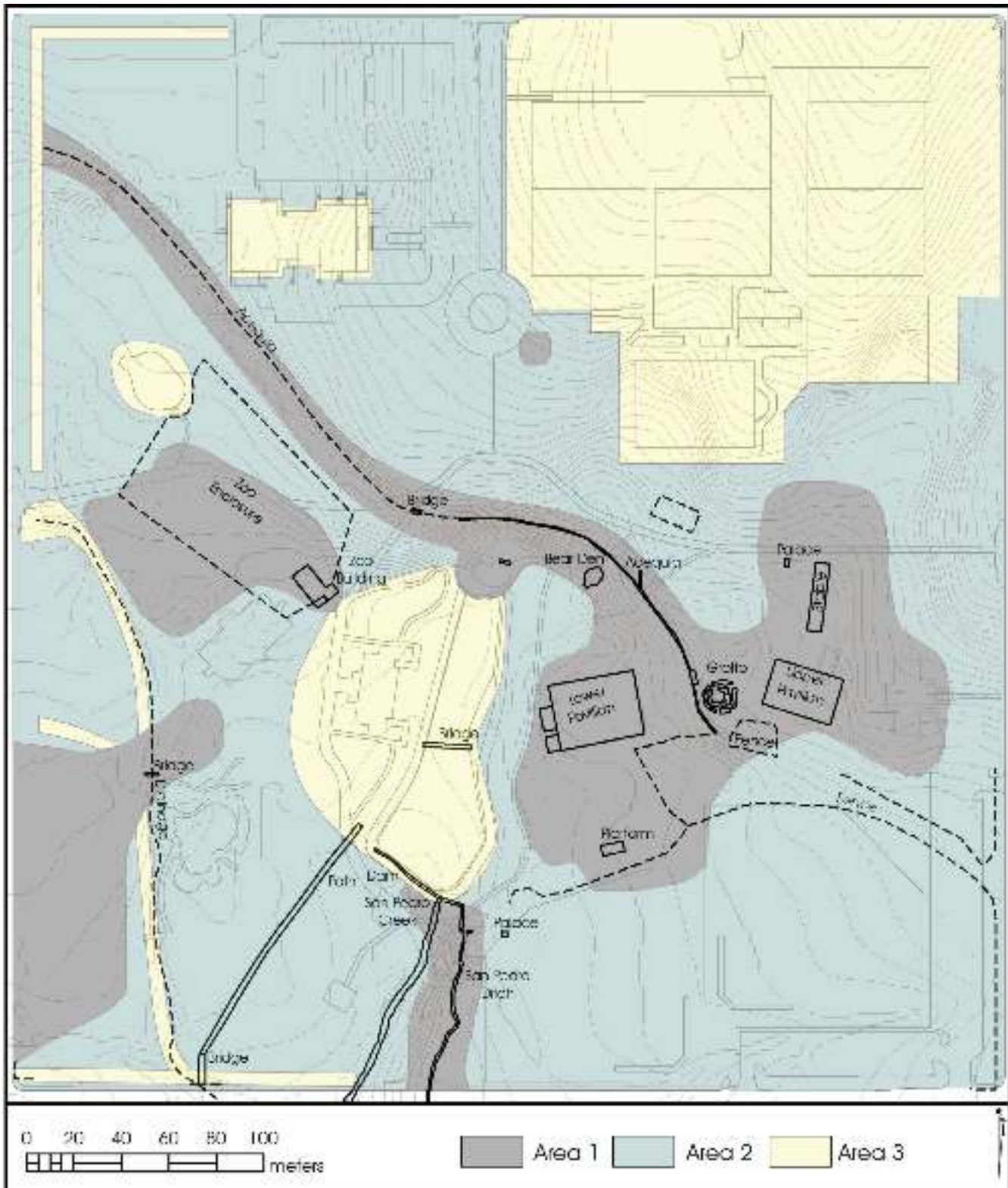

Figure 12-4. Proposed management areas within San Pedro Park.

At the other end of the spectrum is Management Area 1, shown in light gray in Figure 12-4. These are areas where subsurface disturbances should be avoided. These include most of Meissner's Zone 1, as well as several additional areas based on the current work. These areas have, or are likely to have, intact cultural deposits, contain culturally significant features, or have a high potential to contain intact material near the surface that has not yet been clearly defined. The areas around TU 4, as well as TU 7 above the old stables, would fall into the latter category. If avoidance is not possible, then CAR recommends a focused investigation of the areas where any disturbance is proposed.

Management Area 2, in light blue in Figure 12-4, includes all other areas of the park. It encompasses large sections of Meissner's Zones 2 and 3 (see Figure 12-1). These are areas where extensive surface disturbance has been demonstrated to below 30 cm and that are outside of Areas 1 and 3. If extensive impacts are to occur at depths below 30 cm, CAR would recommend a focused investigation of those impacts. Note that Management Area 2 includes the locations of the softball field. While it could be argued that this should be classified as Area 3, not enough is known about the field history and sediment beyond the 1-x-1 m unit and shovel testing in the outfield grass. It seems unlikely that a significant amount of fill was brought in to this area. However, the deposits, at least in the areas that were sampled, are out of context. Until more is known about the history of the deposits and given the lack of post-eighteenth-century material in the park in general, CAR is hesitant to declare all of this large area as lacking integrity. The shovel test data do suggest that the upper 30 cm are degraded, and so this area has been classified as Management Area 2.

Finally, note that San Pedro Springs is not only the birthplace of the City of San Antonio, it was a focus of human activities for thousands of years before 1709, and it has

had a colorful history since that date. Web sites, such as Eckhardt's (2014) discussion of San Pedro Springs history, highlight quirky park events, from horseback riding contests to balloon parachutists to cricket and polo contests. While the prehistoric events are less specific, there are burned rock features, dense trash middens, and the remains of bison and other animals consumed by Native Americans. Surprisingly, visitors to San Pedro Park today can come away with almost no understanding of its varied and interesting past. As a final recommendation, CAR suggests that a public educational component be developed within the park. At a minimum, improved signage, with period photographs, postcards, maps, drawings, and artifact photographs could be provided at several display areas within the park. The period specific photographs and postcards could be selected such that they provide the same perspective as that faced by a park visitor. Interpretive text, in both Spanish and English, could also be provided at each location. In addition, Quick Response (QR) Codes and web links to bilingual sites that could provide more detailed, immediate feedback regarding different areas within the park could be developed for each display area. By scanning the code or entering the web link, a park visitor could be connected to detailed information about that specific location within the park. An additional component of this educational approach would be to construct a permanent exhibit regarding the history and prehistory of the park and to locate that exhibit in the San Pedro Park branch of the San Antonio Library. This would provide more secure display possibilities, and the existence of the exhibit could be linked to park displays, potentially drawing park visitors to the library facilities. Opportunities would also exist for educational programs about the park run through the library. The combination of bilingual text, period pictures, bilingual web sites, and the development of a synergistic relationship between the park and the library would maximize the dissemination of information about an under appreciated San Antonio resource.

References Cited:

- Acuna, L.I.
2006 The Economic Contribution of Root Foods and Other Geophytes in Prehistoric Texas. Unpublished Master's thesis, Department of Anthropology, Texas State University, San Marcos.
- Alley, W.M.
1984 The Palmer Drought Severity Index: Limitations and Applications. *Journal of Climate and Applied Meteorology* 23:1100-1109.
- Anderson, D.G.
1996 Models of Paleo-Indian and Early Archaic Settlement in the Lower Southeast. In *The Paleoindian and Early Archaic Southeast*, edited by D.G. Anderson and K.E. Sassaman, pp. 29-57. University of Alabama Press, Tuscaloosa.
- Andrefsky, W.
1998 *Lithics: Macroscopic Approaches to Analysis*. Cambridge Manuals in Archaeology, Cambridge.
- Andrews, B.N., J.M. Labelle, and J.D. Seebach
2008 Spatial Variability in the Folsom Archaeological Record: A Multi-scalar Approach. *American Antiquity* 73:464-490.
- Bandelier, F.R.
1905 *The Narrative of Alvar Nuñez Cabeza de Vaca by Alvar Nuñez Cabeza de Vaca - 1542, Translated from the Spanish by F. R. Bandelier, 1905*. Imprint Society Reprint, Barre, Massachusetts, 1972.
- Barker, E.C.
1928 *Mexico and Texas: 1821-1835*. P.L. Turner Company, Dallas.
- Barker, R.A., P.W. Bush, and E.T. Baker, Jr.
1994 *Geologic History and Hydrogeologic Setting of the Edwards-Trinity Aquifer System, West-Central Texas*. Water Resources Investigations Report 94-4039. U.S. Geological Survey, Earth Science Center, Washington, D.C.
- Barnes, C.M.
1910 Many and Mammoth Caves Found in and about San Antonio. They have their Histories - Some with Tragic Ones. A Stolen Church Organ Hidden in One. In *Combats and Conquests of Immortal Heroes Sung in Song and Praised in Poem*, pp. 100-101. Guessaz and Ferlet Comp., San Antonio, Texas.
- Barnes, V.E.
1983 Geological Atlas of Texas. San Antonio Sheet. Robert Hamilton Cuyler Memorial ed. Bureau of Economic Geology, The University of Texas at Austin.
- Bartlett, J.R.
1965 [1854] *Personal Narrative of the Expedition and Incidents Connected with the United States and Mexican Border Commission*. Rio Grande Press, Glorieta, New Mexico.
- Bauer, K.J.
1974 *The Mexican War, 1846-1848*. MacMillan, New York.
- Baugh, D.
2011 *The Global Seven Years War, 1754-1763: Britain and France in a Great Power Contest*. Modern Wars in Perspective. Pearson Press, London.
- Beaty Palmer Architects
2013 San Pedro Springs Park Master Plan. PDF presentation on file, City of San Antonio archives.

- Bellomo, R.V.
1993 A Methodological Approach to Identifying Archaeological Evidence of Fire Resulting from Human Activities. *Journal of Archaeological Science* 20:523-553.
- Bement, L.C.
1986 *Excavations of the Late Pleistocene Deposits of Bonfire Shelter, Val Verde County, Texas*. Texas Archeological Survey, Archeology Series 1. University of Texas, Austin.
1994 *Hunter and Gatherer Mortuary Practices during the Central Texas Archaic*. University of Texas Press, Austin.
- Bever, M.R., and D.J. Meltzer
2007 Exploring Variation in Paleoindian Lifeways: The Third Revised Edition of the Texas Clovis Fluted Point Survey. *Bulletin of the Texas Archeological Society* 78:65-99.
- Black, J.
1985 The Anglo-French Alliance 1716-1731. A Study in Eighteenth-Century International Relations. *Francia* 13:295-310.
- Black, S.L.
1986 *The Clemente and Herminia Hinojosa Site, 41JW8: A Toyah Horizon Campsite in Southern Texas*. Special Report, No. 18. Center for Archaeological Research, The University of Texas at San Antonio.
1989 Central Texas Plateau Prairie. In *From the Gulf Coast to the Rio Grande: Human Adaptation in Central, South and Lower Pecos Texas*, edited by T.R. Hester, S.L. Black, D.G. Steele, B.W. Olive, A.A. Fox, K.J. Reinhard, and L.C. Bement, pp. 17-38. Research Series No. 33. Arkansas Archeological Survey, Fayetteville.
- Black, S. L., and D.G. Creel
1997 The Central Texas Burned Rock Midden Reconsidered. In *Hot Rock Cooking on the Greater Edwards Plateau: Four Burned Rock Midden Sites in West Central Texas*, edited by S.L. Black, L.W. Ellis, D.G. Creel, and G.T. Goode, pp. 446-515. Studies in Archeology 22. Texas Archeological Research Laboratory, The University of Texas at Austin.
- Black, S.L., L.W. Ellis, D.G. Creel, and G.T. Goode
1997 *Hot Rock Cooking on the Greater Edwards Plateau: Four Burned Rock Midden Sites in West Central Texas*. Studies in Archeology 22. Texas Archeological Research Laboratory, The University of Texas at Austin; Texas Department of Transportation Environmental Affairs Department, Archeology Studies Program, Report 2.
- Black, S.L., and A.J. McGraw
1985 *The Panther Springs Creek Site: Cultural Change and Continuity in the Upper Salado Creek Drainage, South-Central Texas*. Archaeological Survey Report, No. 100. Center for Archaeological Research, The University of Texas at San Antonio.
- Blair, W.F.
1950 The Biotic Provinces of Texas. *The Texas Journal of Science* 2(1):93-117.
- Bolton, H.E.
1905 The Spanish Abandonment and Re-Occupation of East Texas, 1773-1779. *The Quarterly of the Texas State Historical Association* 9(2):67-137.
- Bomar, G.W.
1995 *Texas Weather*. University of Texas Press, Austin.
- Bonnichsen, R., and K.L. Turnmire (editors)
1991 *Clovis: Origins and Adaptations*. Center for the Study of the First Americans. Oregon State University, Corvallis.
- Bousman, C.B.
1998 Paleoenvironmental Change in Central Texas: The Palynological Evidence. *Plains Anthropologist* 43(164):201-219.

- Bousman, C.B., B.W. Baker, and A.C. Kerr
2004 Paleoindian Archeology in Texas. In *The Prehistory of Texas*, edited by T.K. Perttula, pp. 15-97. Texas A&M University Press, College Station, Texas
- Bousman, C.B., and M. Quigg
2006 Stable Carbon Isotopes from Archaic Human Remains in the Chihuahuan Desert and Central Texas. *Plains Anthropologist* 51(198):123-139.
- Bradley, B.A., M.B. Collins, and A. Hemmings
2010 *Clovis Technology*. International Monographs in Prehistory: Archaeological Series 17. Ann Arbor.
- Bronk Ramsey, C.
2009 Bayesian Analysis of Radiocarbon Dates. *Radiocarbon* 51(1):337-360.
- Brune, G.
1981 *Springs of Texas*. Branch-Smith, Fort Worth.
- Buckley, E.C.
1911 The Aguayo Expedition into Texas and Louisiana, 1719-1722. *Quarterly of the Texas State Historical Association* 15(1):1-65.
- Campbell, R.
1989 *An Empire for Slavery: The Peculiar Institution in Texas, 1821-1865*. Louisiana State University Press, Baton Rouge.
2003 *Gone to Texas: A History of the Lone Star State*. Oxford University Press, New York.
- Camper, H.A.
1991 Pollen Analysis of Patschke Bog. Unpublished Master's thesis, Department of Botany, Texas A&M University, College Station.
- Cargill, D.A.
1996 Stable Isotope Analysis at Mission San Juan de Capistrano, San Antonio, Texas. Unpublished Master's thesis, Department of Anthropology, The University of Texas at San Antonio.
- Carlson, S.B.
1994 Texas Beyond the Periphery: An Archaeological Study of the Spanish Missions during the Eighteenth Century. Unpublished Ph.D. dissertation, Department of Anthropology, Texas A&M University, College Station.
- Castaneda, C.E.
1936 *Our Catholic Heritage in Texas 1519-1936: Volume (2) - The Mission Era: The Winning of Texas 1693-1731*. Von Boeckmann Jones, Austin.
- Chabot, F.C.
1932 *Excerpts from the Memorias for the History of the Province of Texas: Being a translation of those parts of the Memorias which particularly concern the various Indians of the Province of Texas; their tribal divisions, characteristics, customs, traditions, superstitions, and all else of interest concerning them. With a Prolog, Appendix, and Notes by Frederick C. Chabot. Covering the period from earliest times to the close of the Memorias by Padre Fray Agustin de Morfi, Lector Jubilado e Hijo de la Provincia del Santo Evangelio de Mexico*. Translated and annotated by Frederick C. Chabot. Translation revised by Carlos E. Castaneda of the University of Texas. Naylor, San Antonio.
1937 *With the makers of San Antonio*. Naylor, San Antonio.
- Chadderdon, M.F.
1983 *Baker Cave, Val Verde County, Texas: The 1976 Excavations*. Special Report, No. 13. Center for Archaeological Research, The University of Texas at San Antonio.

- Chipman, D.E.
1992 *Spanish Texas, 1519-1821*. University of Texas Press, Austin.
- Chipman, D.E., and H.D. Joseph
2010 *Spanish Texas, 1519-1821*. Rev. ed. University of Texas Press, Austin.
- City of San Antonio (COSA)
2014 Subdivision, Civil Engineer, Plat Book 2, 1840-1884. City Engineer Records, 1840-1973, Box 8.5. Office of the City Clerk, Municipal Archives and Records. Electronic document, <https://www.sanantonio.gov/Portals/0/Files/MuniAR/FindingAid/PlatBook2.pdf>, accessed December 2014.
- Cleaveland, M.K., T.H. Votteler, D.K. Stahle, R.C. Casteel, and J.L. Banner
2011 Extended Chronology of Drought in South Central, Southeastern and West Texas. *Texas Water Journal* 2(1):54-96.
- Collins, M.B.
1995 Forty Years of Archeology in Central Texas. *Bulletin of the Texas Archeological Society* 66:361-400.
1998 *Wilson-Leonard: An 11,000 Year Archeological Record of Hunter-Gatherers in Central Texas*. Studies in Archeology 31. Texas Archeological Research Laboratory, The University of Texas at Austin.
1999a *Clovis Blade Technology*. University of Texas Press, Austin.
1999b Gault Site. In *The Handbook of Texas*, edited by R.R. Barkley, pp. 117-118. Texas State Historical Association, Austin.
2003 Gault Site Dates and Findings. *Newsletter of the Friends of the Texas Archeological Laboratory* (May 2003):8-10.
2004 Archeology in Central Texas. In *The Prehistory of Texas*, edited by T.K. Perttula, pp. 205-265. Texas A&M University Press, College Station.
- Collins, M.B., D. Hudler, and S.L. Black
2003 *Pavo Real (41BX52): A Paleoindian and Archaic Camp and Workshop on the Balcones Escarpment, South-Central Texas*. Studies in Archeology 41, Texas Archaeological Research Laboratory, The University of Texas at Austin and Archeological Studies Program, Report 50, Environmental Affairs Division, Texas Department of Transportation, Austin.
- Cook, E.R., and P.J. Krusic
2004 The North American Drought Atlas. Lamont-Doherty Earth Observatory and the National Science Foundation. Columbia University, Palisades, New York. Electronic document, <http://iridl.ldeo.columbia.edu/SOURCES/.LDEO/.TRL/.NADA2004/.pdsi-atlas.html>, accessed November 2013.
- Cook, E.R., D.M. Meko, D.W. Stahle, and M.K. Cleaveland
1999 Drought Reconstruction for the Continental United States. *Journal of Climate* 12:1145-1162.
- Cooke, M.J.
2005 Soil Formation and Erosion in Central Texas: Insights from Relict Soil and Cave Deposits. Unpublished Ph.D. dissertation, The University of Texas at Austin.
- Corner, W.
1890 *San Antonio de Bexar, A Guide and History*. Bainbridge and Corner, San Antonio, Texas.
- Cox, I.W.
1986 *Excavations of Portions of the San Pedro Acequia (41BX337) and a Search for the Arocha Acequia, San Antonio, Texas*. Archaeological Survey Report, No. 161. Center for Archaeological Research, The University of Texas at San Antonio.

- 1997 The Growth of San Antonio. In *Archaeology at the Alamodome: Investigations of a San Antonio Neighborhood in Transition. Volume 1, Historical, Architectural, and Oral History Research*, edited by A.A. Fox, M. Renner, and R.J. Hard, pp. 8-44. Archaeological Report, No. 236. Center for Archaeological Research, The University of Texas at San Antonio.
- 1999 Historic Period. In *Archaeological Survey and Testing in San Pedro Park (41BX19), San Antonio, Texas*, by B.A. Houk, pp. 6-11. Archaeological Survey Report, No. 289. Center for Archaeological Research, The University of Texas at San Antonio.
- 2005a *The Spanish Acequias of San Antonio*. Maverick Publishing Company, San Antonio.
- 2005b History of the "Priest's House" on Military Plaza. In *Test Excavations and Monitoring at 41BX1598*, by A.L. Figueroa and R.P. Mauldin, pp. 125-130. Archaeological Report, No. 360. Center for Archaeological Research, The University of Texas at San Antonio.
- Creel, D.G.
1986 Study of Prehistoric Burned Rock Middens in West Central Texas. Unpublished Ph.D. dissertation, The University of Arizona.
- Crook, C.E.
1967 *San Pedro Springs Park*. Privately printed, San Antonio, Texas.
- Crowther, J.
2003 Potential Magnetic Susceptibility and Fractional Conversion Studies of Archaeological Soils and Sediments. *Archaeometry* 45:685-701.
- Cunningham, D.S.
2006 The Domingo Ramon Diary of the 1716 Expedition into the Province of the Tejas Indians: An Annotated Translation. *Southwestern Historical Quarterly* 110(1):39-67.
- Davis, D.R., Jr.
1991 *Prehistoric Artifacts of the Texas Indians: An Identification and Reference Guide*. Pecos Publishing Company, Pecos, Texas.
- Davis, W.B., and D.J. Schmidly
1997 The Mammals of Texas. Texas Tech University and Texas Parks and Wildlife Department. Nongame and Urban Program, Austin. Electronic database, <http://www.nsrll.ttu.edu/tmot1/Default.htm>, accessed fall 2014.
- Davis, W.C.
2004 *Lone Star Rising*. Free Press, London.
- Dearing, J.
1999 *Environmental Magnetic Susceptibility*. Chi Publishing, Kenilworth, England
- Dering, J.P.
2008 Late Prehistoric Subsistence Economy on the Edwards Plateau. *Plains Anthropologist* 53(205):59-77.
- Dibble, D.S.
1965 *Bonfire Shelter: A Stratified Bison Kill Site in the Amistad Reservoir Area, Val Verde County, Texas*. Texas Archeological Salvage Project Miscellaneous Papers 3. The University of Texas at Austin.
- Dibble, D.S., and D. Lorrain
1968 *Bonfire Shelter: A Stratified Bison Kill Site, Val Verde County, Texas*. Texas Memorial Museum Miscellaneous Papers 1. Austin.

- Dillehay, T.
1974 Late Quaternary Bison Population Changes on the Southern Plains. *Plains Anthropologist* 19(64):180-196.
- Donecker, F.
2014 San Antonio River. Handbook of Texas Online. Texas State Historical Association. Electronic document, <http://www.tshaonline.org/handbook/online/articles/rns06>, accessed July 2014.
- Doolittle, W.E.
2000 *Cultivated Landscapes of Native North America*. Oxford University Press, New York.
- Eckhardt, G.
2014 The Edwards Aquifer Website. Electronic document, <http://www.edwardsaquifer.net/spspring.html>, accessed summer and fall, 2014.
- Ellsworth, C.E.
1923 *The Floods in Central Texas in September, 1921*. U.S. Geological Survey, Water-Supply Paper 488. Government Printing Office, Washington, D.C.
- Ewers, J.C.
1973 The Influence of Epidemics on the Indian Populations and Cultures of Texas. *Plains Anthropologist* 18(60):104-115.
- Favata, M.A., and J.B. Fernandez
1993 *The Account: Nunez Cabeza de Vaca's Relacion*. Arte Publico Press, Houston.
- Fehrenbach, T.R.
1983 *Seven Keys to Texas*. Texas Western Press, El Paso.
2000 *Lone Star: A History of Texas and the Texans*. Da Capo Press, Boston.
2010 San Antonio, Texas. Handbook of Texas Online. Texas State Historical Association. Electronic document, <http://www.tshaonline.org/handbook/online/articles/hds02>, accessed May 9, 2014.
- Ferring, C.R.
2001 *Archaeology and Paleoecology of the Aubrey Clovis Site (41DN479), Denton County, Texas*. Center for Environmental Archaeology, Department of Geography, University of North Texas.
- Foik, P.J.
1933 Captain Don Domingo Ramón's Diary of his Expedition into Texas in 1716. Edited and translated from the Spanish by P.J. Foik, St. Edward's University, Headquarters of the Texas Knights of Columbus Historical Commission, Austin, Texas. *Preliminary Studies of the Texas Catholic Historical Society* 2(5):1-23.
- Forrestal, P.P.
1935 Pena's Diary of the Aguayo Expedition. *Preliminary Studies of the Texas Catholic Historical Society* 2(7):3-68.
- Foster, W.C.
1995 *Spanish Expeditions into Texas, 1689-1768*. University of Texas Press, Austin.
1998 *The La Salle Expedition to Texas: The Journal of Henri Joutel 1664-1687*. Texas State Historical Association, Austin.
2008 *Historic Native Peoples of Texas*. University of Texas Press, Austin.
- Fox, A.A.
1978 *Archaeological Investigations of Portions of the San Pedro and Alazán Acequias in San Antonio, Texas*. Archaeological Survey Report, No. 49. Center for Archaeological Research, The University of Texas at San Antonio.

- Fox, A.A., and I.W. Cox
2000 *Archaeological Monitoring for Exterior Lighting and Test Excavations at Mission San Juan Capistrano, Bexar County, Texas*. Letter Report, No. 131. Center for Archaeological Research, The University of Texas at San Antonio.
- Freeman, J.
2007 *Energy, Intensification, and Subsistence Change: Hunter Gatherer Earth Ovens and Alternatives to Plant Domestication in Central Texas*. Unpublished Master's thesis, The University of Texas at San Antonio.
- Frkuska, A.J.
1981 *Archaeological Investigations at the San Pedro Acequia, San Antonio, Texas*. Archaeological Survey Report, No. 103. Center for Archaeological Research, The University of Texas at San Antonio.
- Garcia, R.
2014 *List of Soldiers and Civilians who Settled San Antonio de Bejar in 1718*. Manuscript on file, Center for Archaeological Research, The University of Texas at San Antonio.
- Givens, R.D.
1968 *A Preliminary Report on Excavations at Hitzfelder Cave*. *Bulletin of the Texas Archeological Society* 38:47-50.
- Goode, G.T.
1991 *Late Prehistoric Burned Rock Middens in Central Texas*. In *The Burned Rock Middens of Texas: An Archaeological Symposium*, edited by T.R. Hester, pp. 71-93. Studies in Archeology 13. Texas Archeological Research Laboratory. The University of Texas at Austin.
2002 *The Anthon Site: A Prehistoric Encampment in Southern Uvalde County, Texas*. Environmental Affairs Division, Archeological Studies Program, Report 38. Texas Department of Transportation, Austin.
- Gould, F.W., G.O. Hoffman, and C.A. Rechenhain
1960 *Vegetational Areas of Texas*. Texas A&M University, Texas Agricultural Experiment Station Leaflet No. 492.
- Greaves, R.D., R.P. Mauldin, and S.A. Tomka
2002 *An Archaeological Survey of Trail Locations in a Portion of Government Canyon State Natural Area, Bexar County, Texas. Vol. 1 Project Summary, Survey Results, and Recommendations*. Archaeological Survey Report, No. 329. Center for Archaeological Research, The University of Texas at San Antonio.
- Greer, J.W.
1976 *Notes on Bison in Val Verde County, Texas: Additions to Dillehay*. *Plains Anthropologist* 21:21-71.
- Greer, J.W., and R.A. Benfer
1975 *Austin Phase Burials at the Pat Parker Site, Travis County, Texas*. *Bulletin of the Texas Archeological Society* 46:189-216.
- Griffith, G.E., S.A. Bryce, J.M. Omernik, J.A. Comstock, A.C. Rogers, B. Harrison, S.L. Hatch, and D. Bezanson
2004 *Ecoregions of Texas*. Reston, Virginia, U.S. Geological Survey (map scale 1:2,500,000).
- Habig, M.A.
1968 *The Alamo Chain of Missions: A History of San Antonio's Five Old Missions*. Franciscan Herald Press, Chicago.
- Hackett, C.W.
2010 *Aguayo Expedition*. Handbook of Texas Online. Texas State Historical Association. Electronic document, <http://www.tshaonline.org/handbook/online/articles/upa01>, accessed August 21, 2014.
- Hall, G.D.
1981 *Allens Creek: A Study in the Cultural Prehistoric of the Brazos River Valley*. Research Report 61. Texas Archeological Survey, The University of Texas at Austin.

- Hard, R.J., and M.A. Katzenberg
2011 Stable Isotope Study of Hunter-Gatherer-Fisher Diet, Mobility, and Intensification on the Texas Gulf Coastal Plain. *American Antiquity* 76:709-751.
- Hatcher, M.A.
1932 The Expedition of Don Domingo Teran de los Rios into Texas (1691-1692). *Preliminary Studies of the Texas Catholic Historical Society* 2(1):3-67.
- Henderson, J.
2001 *Excavations at the Rainey Site (41BN33): A Late Prehistoric Sinkhole Site in Bandera County, Texas*. Archeological Studies Program Report 5. Texas Department of Transportation, Environmental Affairs Division, Austin.
- Henderson, T.J.
2009 *The Mexican Wars for Independence*. Hill and Wang Publishing, New York.
- Hester, T.R.
1975 Late Prehistoric Cultural Patterns along the Lower Rio Grande of Texas. *Bulletin of the Texas Archeological Society* 46:107-126.
1983 Late Paleo-Indian Occupations at Baker Cave, Southwestern Texas. *Bulletin of the Texas Archeological Society* 53:101-119.
1989 Introduction. In *From the Gulf Coast to the Rio Grande: Human Adaptation in Central, South and Lower Pecos Texas*, edited by T.R. Hester, S.L. Black, D.G. Steele, B.W. Olive, A.A. Fox, K.J. Reinhard, and L.C. Bement, pp. 1-4. Research Series No. 33. Arkansas Archeological Survey, Fayetteville.
2004 The Prehistory of South Texas. In *The Prehistory of Texas*, edited by T.K. Perttula, pp. 127-151. Texas A&M Press, College Station.
2005 An Overview of the Late Archaic in Southern Texas. In *The Late Archaic Across the Borderlands: From Foraging to Farming*, edited by B.J. Vierra, pp. 259-278. University of Texas Press, Austin.
- Highley, L., C. Graves, and G. Judson
1978 Archeological Investigations at Scorpion Cave (41ME7), Medina County, Texas. *Bulletin of the Texas Archeological Society* 49:139-194.
- Hoffman, F.L. (translator)
1935 *Diary of the Alarcón Expedition into Texas, 1718-1719, by Fray Francisco*. The Quivira Society, Los Angeles.
1938 The Mezquía Diary of the Alarcón Expedition into Texas, 1718. *Southwestern Historical Quarterly* 41:312-323.
- Hofman, J.L.
1995 Dating Folsom Occupations of the Southern Plains: The Lipscomb and Waugh Sites. *Journal of Field Archaeology* 22:421-437.
- Hooge, J.
2013 Underwater Geoarchaeology at Spring Lake, San Marcos, Texas. Master's thesis, Department of Anthropology, Texas State University, San Marcos.
- Houk, B.A.
1999 *Archeological Survey and Testing in San Pedro Park (41BX19), San Antonio, Texas*. Archeological Survey Report, No. 289. Center for Archaeological Research, The University of Texas at San Antonio.
- Houk, B.A., and J.C. Lohse
1993 Archeological Investigations at the Mingo Site, Bandera County, Texas. *Bulletin of the Texas Archeological Society* 61:193-247.

- Houk, B.A., K.A. Miller, and E.R. Oksanen
2009 The Gatlin Site and Early-to-Middle Archaic Chronology of the Southern Edwards Plateau, Texas. *Bulletin of the Texas Archeological Society* 80:51-75.
- Houk, B.A., D.L. Nickels, and B.A. Meissner
2000 The 1998 Investigations. In *An Archaeological Assessment of San Pedro Park, (41BX19), San Antonio, Texas*, edited by B.A. Meissner, pp. 43-78. Archaeological Survey Report, No. 269. Center for Archaeological Research, The University of Texas at San Antonio.
- Huebner, J.A.
1991 Late Prehistoric Bison Populations in Central and Southern Texas. *Plains Anthropologist* 36(137):343-358.
- Jelks, E.B.
1962 *The Kyle Site: A Stratified Central Texas Aspect Site in Hill Country, Texas*. Archeology Series 5. Department of Anthropology, The University of Texas at Austin.
- Jennings, T.A.
2012 Clovis, Folsom, and Midland Components at the Debra L. Friedkin Site, Texas: Context, Chronology, and Assemblages. *Journal of Archaeological Science* 39:3239-3247.
- Johnson, E. (editor)
1987 *Lubbock Lake: Late Quaternary Studies on the Southern High Plains*. Texas A&M University, College Station.
- Johnson, E., and V.T. Holliday
1989 Lubbock Lake: Late Quaternary Cultural and Environmental Change on the Southern High Plains, USA. *Journal of Quaternary Science* 4:145-165.
- Johnson, L., and G. Goode
1994 A New Try at Dating and Characterizing Holocene Climates, as well as Archaeological Periods, on the Eastern Edwards Plateau. *Bulletin of the Texas Archeological Society* 65:1-15.
- 1995 *Past Cultures and Climates at Jonas Terrace, 41ME29, Medina County, Texas*. Office of the State Archeologist Report 40. Texas Department of Transportation and Texas Historical Commission, Austin.
- 2000 *Life and Death as Seen at the Bessie Kruse Site (41WM13) on the Blackland Prairie of Williamson County, Texas*. Environmental Affairs Division, Archeological Studies Program, Report 22. Austin.
- Johnson, L., Jr.
1994 *The Life and Times of Toyah-Culture Folk as Seen from the Buckhollow Encampment, Site 41KM16, of Kimble County, Texas*. Office of the State Archeologist Report, No. 38. Texas Department of Transportation and Texas Historical Commission, Austin.
- Karbula, J.W.
2003 Toyah Bluff Site (41TV441): Changing Notions of Late Prehistoric Subsistence in the Blackland Prairie, Travis County, Texas. *Bulletin of the Texas Archeological Society* 74:55-81.
- Karl, T.R.
1986 The Sensitivity of the Palmer Drought Severity Index and Palmer's Z-Index to their Calibration Coefficients Including Potential Evapotranspiration. *Journal of Climate and Applied Meteorology* 25:77-86.
- Katzenberg, M.A.
2008 Stable Isotope Analysis: A Tool for Studying Past Diet, Demography, and Life History. In *Biological Anthropology of the Human Skeleton*, edited by M.A. Katzenberg and S.R. Saunders, pp. 413-441. Wiley-Liss, Hoboken, New Jersey.

Kelly, J.C.

- 1947 The Lehman Rockshelter: A Stratified Site of the Toyah, Uvalde and Round Rock Foci. *Bulletin of the Texas Archeological and Paleontological Society* 18:115-128.

Kendall, D.S.

- 2013 San Pedro Park. Handbook of Texas Online. Texas State Historical Association. Electronic document, <http://www.tshaonline.org/handbook/online/articles/gks12>, accessed December 1, 2013.

Kenmotsu, N.A., and J.W. Arnn

- 2012 The Toyah Phase and the Ethnohistoric Record: A Case for Population Aggregation. In *The Toyah Phase of Central Texas: Late Prehistoric Economic and Social Processes*, edited by N.A. Kenmotsu and D.K. Boyd, pp. 19-43. Texas A&M University, College Station.

Kenmotsu, N.A., and D.K. Boyd (editors)

- 2012 *The Toyah Phase of Central Texas: Late Prehistoric Economic and Social Processes*. Texas A&M University College Station.

Krieger, A.D.

- 2002 *We Came Naked and Barefoot, the Journey of Cabeza de Vaca across North America*. Edited by M.H. Krieger. University of Texas Press, Austin.

Labadie, J.H.

- 1987 *An Archaeological and Historical Assessment of the Vista Verde South Project, San Antonio, Texas*. Archaeological Survey Report, No. 156. Center for Archaeological Research, The University of Texas at San Antonio.

Largent, F.B., Jr.

- 1995 Some New Additions to the Texas Folsom Point Database. *Plains Anthropologist* 40:69-71.

Largent, F.B., Jr., M.R. Waters, and D.L. Carlson

- 1991 The Spatiotemporal Distribution and Characteristics of Folsom Projectile Points in Texas. *Plains Anthropologist* 36:323-341

Lohse, J.C., D.J. Kennett, B.J. Culleton, and C.L. Timperley

- 2012 Middle-to-Late Holocene Bison Chronology and Ecology in the South-Central United States. Paper presented at the 77th Annual Meeting of the Society for American Archaeology, Memphis.

Lukowski, P.D.

- 1988 *Archaeological Investigations at 41BX1, Bexar County, Texas*. Archaeological Survey Report, No. 135. Center for Archaeological Research, The University of Texas at San Antonio.

McClellan, R.G., and W.F. Kean

- 1993 Contributions of Wood Ash Magnetism to Archeomagnetic Properties of Fire Pits and Hearths. *Earth and Planetary Science Letters* 119:387-394.

McDonald, D.

- 2013 Diary of Juan Antonio de la Pena. In *Presidio and Militia on the Northern Frontier*, edited by D. Hadely, J.H. Naylor, and M.K. Schuetz-Miller. University of Arizona Press, Tucson.

McGraw, J.A., J.W. Clark, Jr., and E.A. Robbins (editors)

- 1991 *A Texas Legacy: The Old San Antonio Road and the Caminos Reales*. Texas State Department of Highways and Public Transportation, Austin, Texas.

McGraw, J.A., and V.K. Hinds

- 1987 *Chipped Stone and Adobe: A Cultural Resources Assessment of the Proposed Applewhite Reservoir, Bexar County, Texas*. Archaeological Survey Report, No. 163. Center for Archaeological Research, The University of Texas at San Antonio.

Mauldin, R.P.

- 2003a *Exploring Drought in the San Antonio Area between 1700 and 1979*. Special Report, No. 29. Center for Archaeological Research, The University of Texas at San Antonio.
- 2003b Magnetic Sediment Susceptibility Testing. In *Camp Maxey V: Archaeological Testing of Seven Sites on the Camp Maxey Training Facility, Lamar County, Texas*, by R.D. Greaves, pp. 108-222. Archaeological Survey Report, No. 330. Center for Archaeological Research, The University of Texas at San Antonio.

Mauldin, R.P., and A.L. Figueroa

- 2006 *Data Recovery Excavations at 41PR44, Fort Wolters, Parker County, Texas*. Archaeological Report, No. 369. Center for Archaeological Research, The University of Texas at San Antonio.

Mauldin, R.P., R.J. Hard, C.M. Munoz, J.Z. Rice, K. Verostick, D. Potter, and N. Dollar

- 2013 Carbon and Nitrogen Stable Isotope Analysis of Hunter-gathers from the Coleman Site, a Late Prehistoric Cemetery in Central Texas. *Journal of Archaeological Science* 40:1369-1381.

Mauldin, R.P., D.L. Nickels, and C.J. Broehm

- 2003 *Archaeological Testing to Determine the National Register Eligibility Status of 18 Prehistoric Sites on Camp Bowie, Brown County, Texas*. Archaeological Survey Report, No. 334. Center for Archaeological Research, The University of Texas at San Antonio.

Mauldin, R.P., J.L. Thompson, and L. Kemp

- 2012 Reconsidering the Role of Bison in the Terminal Late Prehistoric (Toyah) Period in Texas. In *The Toyah Phase of Central Texas: Late Prehistoric Economic and Social Processes*, edited by N.A. Kenmotsu and D.K. Boyd, pp. 90-110. Texas A&M Press, College Station.

Meissner, B.A. (editor)

- 2000a *An Archaeological Assessment of San Pedro Park (41BX19) San Antonio, Texas*. Archaeological Survey Report, No. 269. Center for Archaeological Research, The University of Texas at San Antonio.
- 2000b The 1996 Investigations. In *An Archaeological Assessment of San Pedro Park (41BX19) San Antonio, Texas*. edited by B.A. Meissner, pp. 17-41. Archaeological Survey Report, No. 269. Center for Archaeological Research, The University of Texas at San Antonio.
- 2000c Recommendations for Management of Cultural Resources at San Pedro Park. In *An Archaeological Assessment of San Pedro Park (41BX19) San Antonio, Texas*, edited by B.A. Meissner, pp. 79-92. Archaeological Survey Report, No. 269. Center for Archaeological Research, The University of Texas at San Antonio.

Metz, M.C.

- 1931 A Check List of the Flora of Bexar County, Texas. Master's thesis, Catholic University of America, Washington, D.C.

Miller, C.

- 2012 *Deep in the Heart of San Antonio*. Trinity University Press, San Antonio.

Munoz, C.M., and R.P. Mauldin

- 2011 Subsistence Strategies. In *Archeological Significance Testing at 41BX17/271, the Granberg Site: A Multi-Component Site along the Salado Creek in Bexar County, Texas*, by C.M. Munoz, R.P. Mauldin, J.L. Thompson, and S.C. Caran, pp. 105-130. Environmental Affairs Division, Archeological Studies Program Report No. 140 Texas Department of Transportation and Archaeological Report No. 393, Center for Archaeological Research, The University of Texas at San Antonio.

Munoz, C.M., R. Mauldin, and R.J. Hard

- 2011b Stable Isotope Analysis of Human Skeletal Remains from 41HY163, with Comparative Analysis of Remains from 41HY161. In *Prehistoric Life, Labor, and Residence in Southeast Central Texas: Results of Data Recovery at 41HY163, the Zatopec Site, San Marcos, Texas*, edited by J.C. Lohse, pp. 343-350. Archaeological Studies Report 18. Center for Archaeological Studies, Texas State University.

- Munoz, C.M, R.P. Mauldin, J.L. Thompson, and S.C. Caran
2011a *Archeological Significance Testing at 41BX17/271, the Granberg Site: A Multi-Component Site along the Salado Creek in Bexar County, Texas*. Environmental Affairs Division, Archeological Studies Program, Report No. 140, Texas Department of Transportation and Archaeological Report No. 393, Center for Archaeological Research, The University of Texas at San Antonio, Texas.
- Munoz, C.M., J.L.Z. Rice, K. Verostick, R.J. Hard, and R.Mauldin
2013 A Stable Isotope Analysis of Hunter-Gatherers from Hitzfelder Cave, Texas. Paper presented at the Texas Academy of Science, Kerrville, Texas.
- National Oceanic and Atmospheric Association (NOAA)
2013 Southern Regional Headquarters. Electronic document, www.srha.noaa.gov/ewx/, accessed fall 2013.
- Natural Resources Conservation Service (NRCS)
2014 Web Soil Survey, United States Department of Agriculture. Electronic document, <http://websoilsurvey.nrcs.usda.gov/app/WebSoilSurvey.aspx>, accessed March 31, 2014
- Neu, C.T.
2013 Annexation. Handbook of Texas Online. Texas State Historical Association. Electronic document, <http://www.tshaonline.org/handbook/online/articles/mga02>, accessed December 1, 2013.
- Nichols, K M.
2014 Archaeological Investigations at the Christopher Columbus Italian Society Property and Columbus Park: 41BX1968, the Possible First Site of Mission San Antonio de Valero. Report on file, Center for Archaeological Research, The University of Texas at San Antonio.
- Nickels, D.L.
2000 The Beisenbach Site (41WN88): A Case Study in Diet Breadth. Unpublished Master's thesis, The University of Texas at San Antonio.
- Nickels, D.L., and I.W. Cox
1996 *An Archaeological Assessment of the Alazán Acequia (41BX620) in the Five Points Area of San Antonio, Bexar County, Texas*. Archaeological Survey Report, No. 253. Center for Archaeological Research, The University of Texas at San Antonio.
- Nickels, D.L., and R.P. Mauldin
2001 The Project Environment. In *Archaeological Survey of Twin Buttes Reservoir, Tom Green County, Texas*, Vol. 1, edited by R.P. Mauldin and D.L. Nickels, pp. 25-38. Archaeological Survey Report, No. 300. Center for Archaeological Research, The University of Texas at San Antonio.
- Nickels, D.L., D.W. Pease, and C.B. Bousman
1997 *Archaeological Survey of Lackland Air Force Base, Bexar County, Texas*. Archaeological Survey Report, No. 248. Center for Archaeological Research, The University of Texas at San Antonio.
- Nordt, L. C., T.W. Boutton, J.S. Jaco, and R. Mandel
2002 C₄ Plant Productivity and Climate CO₂ Variations in South-Central Texas during the Late Quaternary. *Quaternary Research* 58(2):182-188.
- Oksanen, E.
2008 Archaeological Investigations at the Icehouse Site, 41HY161: A Reevaluation of Early Archaic Technology, Subsistence and Settlement along the Balcones Escarpment and Central Texas. Master's thesis, Department of Anthropology, Texas State University, San Marcos.

- Orchard, C.D., and T.N. Campbell
1960 Southwestern Pottery from Sites in the Vicinity of San Antonio, Texas. *Texas Archeology, The Newsletter of the Texas Archeological Society* 4(2):7-8.
- Porter, C.R., Jr.
2011 *Spanish Water, Anglo Water*. Texas A&M University Press, College Station.
- Potter, D.R.
2005 Salvage Excavations at the Coleman Site. *La Tierra* 32:19-26.
- Potter, D.R., C.K. Chandler, and E. Newcomb
1992 *Archaeological Salvage Research at 41BX901, a Prehistoric Quarry in Bexar County, Texas*. Archaeological Survey Report, No. 211. Center for Archaeological Research, The University of Texas at San Antonio.
- Prewitt, E.R.
1974 *Archeological Investigations at the Loeve-Fox Site, Williams County, Texas*. Research Report 49, Texas Archeological Survey, The University of Texas at Austin.
1981 Culture Chronology in Central Texas. *Bulletin of the Texas Archeological Society* 52:65-89.
1985 From Circleville to Toyah: Comments on Central Texas Chronology. *Bulletin of the Texas Archeological Society* 54:201-238.
- Quigg, J.M., J.D. Owens, P.M. Matchen, R.A. Ricklis, G.D. Smith, C.D. Frederick, and M.C. Cody
2008 *The Varga Site: A Multicomponent, Stratified Campsite in the Canyonlands of Edwards County, Texas*. TRC Technical Report 35319 and Texas Department of Transportation, Environmental Affairs Division, Archeological Studies Program Report No. 110, Austin.
- Quigg, J.M., and J. Peck
1995 *The Rush Site (41TG346): A Stratified Late Prehistoric Locale in Tom Green County, Texas*. Technical Report, No. 816C. TRC Mariah Associates, Austin.
- Ramsdell, C.W.
1959 *San Antonio: A Historical and Pictorial Guide*. University of Texas Press, Austin.
- Reed, S.G.
1941 *A History of the Texas Railroads*. St. Clair Publishing Company, Houston.
- Reynolds, R.L., and J.W. King
1995 Magnetic Records of Climate Change. U.S. National Report to I.U.G.G., 1991-1994. American Geophysical Union. Electronic document, <http://www.agu.org/revgeophys/reyno100/reyno100.html>, accessed fall 2014.
- Ricklis, R.A.
1994a Occupations in the Project Area during the Austin Interval, or Early Part of the Late Prehistoric Period. In *Archaic and Late Prehistoric Human Ecology in the Middle Onion Creek Valley, Hays County, Texas*, edited by R.A. Ricklis and M.B. Collins, pp.191-205. Studies in Archeology 19. Texas Archeological Research Laboratory, The University of Texas at Austin.
1994b Toyah Components: Evidence for Occupations in the Project Area during the Latter Part of the Late Prehistoric Period. In *Archaic and Late Prehistoric Human Ecology in the Middle Onion Creek Valley, Hays County, Texas*, Vol. 1, edited by R.A. Ricklis and M. Collins, pp. 207-316. Studies in Archeology 19. Texas Archeological Research Laboratory, The University of Texas at Austin.
- Ricklis, R.A., and M.B. Collins
1994 *Archaic and Late Prehistoric Human Ecology in the Middle Onion Creek Valley, Hays County, Texas*. Studies in Archeology 19. 2 vols. Texas Archeological Research Laboratory, The University of Texas at Austin.

Riley, T.

- 2008 Diet and Seasonality in the Lower Pecos: Evaluating Coprolite Data Sets with Cluster Analysis. *Journal of Archaeological Science* 35(10):2726-2741.
- 2012 Assessing Diet and Seasonality in the Lower Pecos Canyonlands: An Evaluation of Coprolite Specimens as Records of Individual Dietary Decisions. *Journal of Archaeological Science* 39(1):145.

RVBK Architects

- 1994 Conceptual Master Plan/San Pedro Springs Park. On file, City of San Antonio archives.

San Antonio Daily Express (SADE)

- 1899 Commissioners Report. 12 September. San Antonio. Copy on file, Center for Archeological Research, The University of Texas at San Antonio.
- 1902 Cave Found Near San Pedro Park. 30 March. San Antonio. Copy on file, Center for Archeological Research, University of Texas at San Antonio.

San Antonio Express (SAE)

- 1935 Neat. 4 August. San Antonio. Copy on file, Center for Archaeological Research, The University of Texas at San Antonio.

San Antonio Light (SAL)

- 1899 The Springs Park. 4 July. San Antonio. Copy on file, Center for Archeological Research, The University of Texas at San Antonio.
- 1899 San Pedro Springs. 27 August. San Antonio. Copy on file, Center for Archeological Research, The University of Texas at San Antonio.
- 1909 Indian Tomb Yields Dead. 4 March. San Antonio. Copy on file, Center for Archeological Research, The University of Texas at San Antonio.
- 1909 Indian Tomb Found Near San Pedro Park Draws Throng. 7 March. San Antonio. Copy on file, Center for Archeological Research, The University of Texas at San Antonio.
- 1915 Large Canal in Park May Avert Floods. 17 January. San Antonio. Copy on file, Center for Archeological Research, The University of Texas at San Antonio.

Sellards, E.H.

- 1919 *The Geology and Mineral Resources of Bexar County*. University of Texas Bulletin No. 1932, Bureau of Economic Geology and Technology, University of Texas at Austin.

Shafer, H.

- 1977 Late Prehistory of Central Texas. *South Plains Archeological Society* 3:18-27.

Simner, M.

- 2013 The War of the Quadruple Alliance. Electronic document, <http://marksimner.me.uk/the-war-of-the-quadruple-alliance>, accessed May, 2014.

Singer, M.J., and P. Fine

- 1989 Pedogenic Factors Affecting Magnetic Susceptibility of Northern California Soils. *Soil Science of America Journal* 53:1119-1127

Skelton, D.W.

- 1977 *Archeological Investigations at the Fayette Power Project, Fayette County, Texas*. Texas Archeological Survey Research Report No. 60. Texas Archeological Survey, The University of Texas at Austin.

- Smith, S., R. Mauldin, C.M. Munoz, R. Hard, D. Paul, G. Skrzypek, P. Villanueva, and L. Kemp
2014 Exploring the Use of Stable Carbon Isotope Ratios in Short-lived Leporids for Local Paleocological Reconstruction. *Open Journal of Archaeometry* 2:81-87.
- Sonnichsen, C.L.
1950 *Cowboys and Cattle Kings*. University of Oklahoma Press, Norman.
- Spearing, D.
1991 *Roadside Geology of Texas*. Roadside Geology Series. Mountain Press Publishing Company, Missoula, Montana.
- Speer, R.D.
1990 History of the Plainview Site. In *Guidebook to the Quaternary History of the Llano Estacado*, edited by V.T. Holliday and E. Johnson, pp. 79-92. Lubbock Lake Landmark Quaternary Research Series 2. Texas Tech University, Lubbock.
- Story, D.A.
1985 Adaptive Strategies of Archaic Cultures of the West Gulf Coastal Plain. In *Prehistoric Food Production in North America*, edited by R.I. Ford, pp. 19-56. Anthropological Papers No. 75. Museum of Anthropology, University of Michigan, Ann Arbor.
- Stover, S.E.
1996 San Pedro Springs Park, Texas. Design, Winter, 1996. U.S. Department of Interior, National Park Service, A Park Practice Program Publication, Washington, D.C.
- Suhm, D.A.
1957 Excavations at the Smith Rockshelter, Travis County, Texas. *Texas Journal of Science* 9:26-58.
- Taylor, A.J., and C.L. Highley
1995 *Archaeological Investigations at the Loma Sandia Site (41LK28): A Prehistoric Campsite in Live Oak County, Texas*. Studies in Archeology No. 20. Texas Archeological Research Laboratory. The University of Texas at Austin.
- Taylor, F.B., R.B. Hailey, and D.L. Richmond
1991 *Soil Survey, Bexar County, Texas*. Soil Conservation Service, U.S. Department of Agriculture and the Texas Agricultural Experimental Station.
- Texas Historical Commission (THC)
2013 Site Records for 41BX19. Texas Archeological Sites Atlas. Electronic document, <http://nueces.thc.state.tx.us/> accessed January, 2013.
- Texas Natural Resources Information System (TNRIS)
2014 Natural Regions. Electronic document, <https://tnris.org/data-download/#!/statewide>, accessed fall 2014.
- Texas Parks and Wildlife Department (TPWD)
1984 TPWD GIS Data. Texas Parks and Wildlife Department. Map on file, Center for Archaeological Research, The University of Texas at San Antonio.
2014 Biotic Provinces of Texas. Texas Parks & Wildlife Department GIS Lab. Electronic document, http://www.tpwd.state.tx.us/publications/pwdpubs/media/pwd_mp_e0100_1070ae_08.pdf, accessed March 2013.
- Texas State Library and Archivist Commission (TSLAC)
2014 Hard Road to Texas, Texas Annexation 1836-1845. Electronic document, <https://www.tsl.texas.gov/exhibits/annexation/index.html>, accessed May 2014.
- Thoms, A.V.
2008 Ancient Savannah Roots of the Carbohydrate Revolution in South-Central North America. *Plains Anthropologist* 53(205):121-136.

- Thoms, A.V., and S.W. Ahr
1995 The Pampopa-Talon Crossings and Heerman Ranch Sites: Preliminary Results of the 1994 Southern Texas Archaeological Association Field School. *La Tierra* 22(2):34-67.
- Thoms, A.V., D.D. Keuhn, B.W. Olive, J.E. Dockall, P.A. Clabaugh, and R.D. Mandel
1996 Early and Middle Holocene Occupations at the Richard Beene Site: The 1995 Southern Texas Archaeological Association Field School Project. *La Tierra* 23(4):8-36.
- Toomey, R.S.
1993 Late Pleistocene and Holocene Faunal Environmental Changes at Hall's Cave, Kerr County, Texas. Unpublished Ph.D. dissertation, The University of Texas at Austin.
- Tous, G. (translator)
1930a The Espinosa-Olivares-Aguire Expedition of 1709. *Preliminary Studies of the Texas Catholic Historical Society* 1(3):3-14.
1930b Ramon's Expedition: Espinosa's Diary of 1716. *Preliminary Studies of the Texas Catholic Historical Society* 1(4):4-24.
- Treece, A.C., C. Lintz, W.N. Trierweiler, J.M. Quigg, and K.A. Miller
1993 *Cultural Resources Investigations in the O.H. Ivie Reservoir, Concho, Coleman, and Runnels Counties, Texas. Volume IV Data Recovery from Ceramic Sites*. Technical Report 346-IV, Austin, Texas Mariah Associates.
- Trust for Public Land
2014 The Oldest City Parks. Center for Park Excellence. Electronic document, www.tpl.org/ccps, accessed spring 2015.
- Turner, B.L., H. Nichols, G. Denny, and O. Doron
2003 *Atlas of the Vascular Plants of Texas*. Botanical Research Institute of Texas, Fort Worth.
- Turner, S.E., and T.R. Hester
1999 *A Field Guide to Stone Artifacts of Texas Indians*. 3rd ed. Gulf Publishing, Houston.
- Turner, S.E., T.R. Hester, and R.L. McReynolds
2011 *Stone Artifacts of Texas Indians*. Taylor Trade Publishing, Boulder, Colorado.
- Turpin, S.A.
2004 The Lower Pecos River Region of Texas and Northern Mexico. In *The Prehistory of Texas*, edited by T.K. Perttula. Vol. 9., pp. 266-180. Texas A&M University Press, College Station.
- Uecker, H.G.
1991 *Archival and Historical Research for the San Pedro Creek Channel Improvement Project: The 1989-1990 Investigations*. Archaeological Survey Report, No. 199. Center for Archaeological Research, The University of Texas at San Antonio.
2004 *Archeological Monitoring of Tree Plantings for the City of San Antonio Arborist, San Pedro Springs Park, San Antonio, Bexar County, Texas*. Report of Investigations No. 8. South Texas Archeological Research Services, Bulverde, Texas.
- United States Geological Survey (USGS)
2014a Edwards Balcones Fault Zone Aquifer. U.S. Department of the Interior. Electronic document, <http://water.usgs.gov/ogw/karst/aquifers/edwards/index>, accessed June 2014.
2014b What is Karst? U.S. Department of the Interior. Electronic document, <http://water.usgs.gov/ogw/karst/pages/whatiskarst>, accessed June 2014.

- Wade, M.
2003 *The Native Americans of the Texas Edwards Plateau, 1582–1799*. University of Texas Press, Austin.
- Wadley, A.N., and S.A. Tomka
2013 *Archaeological Monitoring of Drainage Pipe Trenching in the Vicinity of the San Pedro Playhouse, San Pedro Springs Park, San Antonio, Bexar County, Texas*. Technical Report, No. 52. Center for Archaeological Research, The University of Texas at San Antonio.
- Waguespack, N.M., and T.A. Surovell
2003 Clovis Hunting Strategies, or How to Make Out on Plentiful Resources. *American Antiquity* 68:333-352.
- Wallace, E.
1965 *Texas in Turmoil, 1849–1875*. Steck-Vaughn, Austin.
- Wallen, C.C.
1966 Arid Zone Meteorology. In *Arid Lands*, edited by E.S. Hill, p. 31-51. Methuen, London.
- Waters, M.R., S.L. Forman, T.A. Jennings, L.C. Nordt, S.G. Driese, J.M. Feinberg, J.L. Keene, J. Halligan, A. Lindquist, J. Pierson, C.T. Hallmark, M.B. Collins, and J.E. Wiederhold
2011 The Buttermilk Creek Complex and the Origins of Clovis at the Debra L. Friedkin Site, Texas. *Science* 331:1599-1603.
- Weber, D.J.
1982 *The Mexican Frontier, 1821–1846: The American Southwest under Mexico*. University of New Mexico Press, Albuquerque.
1992 *The Spanish Frontier in North America*. Yale University Press, New Haven.
- Weddle, R.A.
1968 *San Juan Bautista: Gateway to Spanish Texas*. University of Texas Press, Austin.
- Weir, F. A.
1976 The Central Texas Archaic. Unpublished Ph.D. dissertation, Washington State University.
- Weniger, D.
1997 *The Explorers' Texas: The Animals They Found*. Eakin Press, Austin, Texas.
- Woodruff, C.M., and P.L. Abbott
1986 Stream Piracy and Evolution of the Edwards Aquifer along the Balcones Escarpment, Central Texas. In *The Balcones Escarpment*, edited by P.L. Abbott and C.M. Woodruff, pp. 51-54. San Antonio: Geological Society of America, San Antonio.
- Woolford, S.W.
1935 *Types of Archaeological Sites in Bexar County, Texas*. Archaeological Bulletin No. 4, Witte Memorial Museum, Brackenridge Park, San Antonio.
1963 *San Antonio-A History for Tomorrow*. Naylor, San Antonio
- Wormington, H.M.
1957 *Ancient Man in North America*. 4th ed. Denver Museum of Natural History, Denver.
- Zapata, J.E., and B. A. Meissner
2003 *San Pedro Springs Park Improvements, Archaeological Testing and Monitoring at 41BX19, San Antonio, Bexar County, Texas*. Archaeological Survey Report, No. 331. Center for Archaeological Research, The University of Texas at San Antonio.

Appendix A:
Radiocarbon Information

Raymond Mauldin
Paleo-Research Laboratory
CAR-UTSA

Appendix A

Radiocarbon Information

*Raymond Mauldin
Paleo-Research Laboratory
CAR-UTSA*

Six radiocarbon dates were obtained from 41BX19. Initially, two samples were sent to Beta Analytic for analysis. The initial sample (Beta 390003) was from TU 4, Level 9, and was on a small piece of wood charcoal. A second sample (Beta 390004) was from TU 5, Level 9. This was also on a small piece of wood charcoal. Given the contexts and location, both samples were expected to return Late Archaic dates. Beta 390003 produced a date of 680 +/- 30 BP. Correcting for the stable carbon isotopic value of the dated piece ($\delta = -25.5\text{‰}$) produced a date of 670 +/- 30 BP. Beta reported the corrected, calibrated age spans at 2 sigma as Cal AD 1275 to 1315 (Cal BP 675 to 635) and Cal AD 1355 to 1390 (Cal BP 595 to 560). The second sample, Beta 390004, produced a date of 980 +/- 30 BP. Correcting for the stable carbon isotopic value of the dated piece ($\delta = -24.7\text{‰}$) produced the same date (980 +/- 30 BP). Beta reported the corrected, calibrated age spans at 2 sigma as Cal AD 1015 to 1050 (Cal BP 935 to 900) and Cal AD 1080 to 1150 (Cal BP 870 to 800).

Given that these two samples were both significantly later than anticipated and given the potential for displacement of small items, CAR staff attempted to identify faunal samples that would be suitable for dating. Over the last few years, the Paleo-Research Laboratory (PRL) at the Center for Archaeological Research has isolated bone collagen from several thousand faunal samples, and, in combination with Colorado Plateau Stable Isotope Laboratory at Northern Arizona University (CPSIL-NAU) and DirectAMS/Accium Biosciences in Seattle, the PRL has conducted isotopic analysis and radiocarbon dating on several hundred of these samples (Mauldin et al. 2013). For the current project, seven samples were selected from various contexts, including samples from both TU 5 and TU 4. Radiocarbon sample preparation initially involved an assessment of the stable isotopic signature, for calibration, as well as an assessment of the carbon to nitrogen (C:N) ratio of the potential collagen sample. Isotopic preparation was initially conducted at the PRL, and subsequently, samples were analyzed at the CPSIL-NAU and DirectAMS.

PRL-CAR Sample Preparation and Isotopic Analysis

Each bone sample was examined, and a section was selected for sampling. A hand-held rotary sander was used to grind off the surface in this area. Then, a small cutting wheel was used to remove a section of bone for subsequent analysis. This section was placed in a clean glass test tube and washed in ultra-pure (Type 1) water in an ultrasonic bath. Following that washing, the bone samples were dried under low heat (50°C) in a dry bath.

For the initial isotopic analysis of the bone collagen, a section of the cleaned, dry samples was removed and lightly crushed in a mortar and pestle into small fragments (0.5-2 mm size). The resulting material was again washed in an ultrasonic bath with Type 1 water. The water was changed after each 60-minute cycle until the water was clear. The samples were then removed and dried under low heat. For each sample, roughly 200 mg of bone was weighed out and split into two clean glass test tubes. PRL staff added 0.5N HCL to each test tube and refrigerated the capped samples at 4°C to decalcify the bone (see Bocherens et al. 1991; DeNiro and Epstein 1981; Longin 1971). After 30 hours, samples were rinsed to neutral with Type 1 water. They were treated with 0.1N NaOH for 45 minutes at room temperature to remove humic acids and some lipids. Samples were again rinsed to neutral in Type 1 water. Following the NaOH treatment, samples were solubilized in 0.01N HCl at 70°C for 11 hours in a heating block. The supernatant was filtered through coarse fitted filters into glass vials. These were capped, sealed, and frozen at -29°C. The frozen samples were freeze-dried under vacuum to isolate collagen. Roughly 600 µg of collagen was weighed into tin capsules for bulk stable carbon and nitrogen isotope analysis (see Munoz et al. 2011).

Collagen was not preserved on three of the initial seven samples from 41BX19. All three were from the TU 4 area. Faunal material that lack collagen tend to be older and tend to have a different exposure history, with samples being exposed to

more extreme conditions of heat and/or moisture. The four remaining samples produced collagen, and these were sent to the CPSIL-NAU for analysis. Collagen samples were analyzed using a Thermo-Electron Delta V Advantage Isotope Ratio Mass Spectrometer (IRMS) configured through the CONFLO III and attached to a Carlo Erba NC2100 elemental analyzer. Both carbon and nitrogen isotopic composition for a given collagen sample were obtained during a single run. The CPSIL-NAU uses standards from the IAEA (International Atomic Energy Agency) and the National Institute of Standards and Technology (NIST), along with a variety of internal standards for calibration and raw data normalization. Collagen carbon ($\delta^{13}\text{C}$) is reported in per mil (‰) relative to the Vienna Pee Dee Belemnite (V-PDB) standard. Nitrogen ($\delta^{15}\text{N}$) values are reported relative to AIR and are also reported in per mil. The CPSIL-NAU has an uncertainty of $\leq 0.10\text{‰}$ for $\delta^{13}\text{C}_{\text{collagen}}$ and $\leq 0.20\text{‰}$ for $\delta^{15}\text{N}$ based on repeated runs.

Stable isotope results for the four samples, along with a standard, are presented in Table A-1. Note that two separate analyses were conducted on each San Pedro bone collagen sample. In the table, these are referred to as Sample 1 and Sample 2. CAR 348 is a previously run standard, with an average of $-9.9 \delta^{13}\text{C}$ and $7.4 \delta^{15}\text{N}$ based on previous runs. The atomic C:N ratio is also reported in the table. This ratio is a measure of collagen quality (see Ambrose and Norr 1992; Van Klinken 1999). Collagen samples below a value of 3.1 or above a value of 3.5 are not routinely sent for radiocarbon dating. An examination of the C:N ratio in Table A-1 shows that all samples are within the acceptable range.

Table A-1. Isotopic Results from Bone Selected for Radiocarbon Dating, 41BX19

CAR C14 #	Description	Atomic C:N Ratio	$\delta^{13}\text{C}$ ‰ (Sample 1)	$\delta^{13}\text{C}$ ‰ (Sample 2)	$\delta^{15}\text{N}$ ‰ (Sample 1)	$\delta^{15}\text{N}$ ‰ (Sample 2)
CAR 344	FS 3- bison	3.31	-10.96	-10.98	7.57	7.63
CAR 345	FS 152- large mammal	3.29	-18.11	-18.18	5.44	5.55
CAR 346	FS 104- very large mammal	3.3	-12.99	-12.92	8.56	8.44
CAR 347	FS 9- mammal	3.33	-19.7	-19.72	6.34	6.37
CAR 348	Bison 1- sample 348	3.29	-9.75	-9.75	7.56	7.56

PRL-CAR Sample Preparation and Radiocarbon Analysis

For the isolation of bone collagen suitable for radiocarbon date, an acid-base-acid preparation procedure was used on the 41BX19 material (see Brock et al. 2010; Minami et al. 2004). All glasswear used in the process was autoclaved prior to use, and all test tubes were also heated to 450°C for a minimum of 2 hours to assure that no organic contaminants were present. For a given bone sample, PRL staff initially lightly crushed the clean bone with a ceramic mortar and pestle. These crushed bone samples were sonicated in Type 1 water, with the water changed after each run, until the rinse water was clear. Samples were then dried in a covered dry bath at 50°C . Two 100 to 150 mg sub-samples of clean, dried bone were weighed into glass test tubes for each of the samples. These sub-samples were then decalcified with 0.5N HCl at 4°C for 30 hours. After washing to neutral, each sub-sample was then treated with 0.1N NaOH for up to 45 minutes at room temperature, and sub-samples are again washed to neutral. They were then covered with 0.5N HCl and again refrigerated at 4°C for roughly 12 hours. The 0.5 HCl was then replaced with 0.01 HCl without exposing the decalcified bone to air. Sub-samples were solubilized in the 0.01 HCl at 70°C for 20 hours in a covered dry bath. The solubilized samples were then vacuum filtered through individual 0.45 um silver filter membranes to eliminate larger contaminants. Samples were drawn into glass vials and then placed in a freezer at -29°C . Frozen samples were subsequently freeze-dried for roughly 36 hours. The sample vials were then sealed and shipped for analysis.

Radiocarbon samples were analyzed by DirectAMS/Accium Biosciences in Seattle (Zoppi et al. 2007). The collagen samples were combusted and reduced to graphite in sealed vials and measured using a National Electrostatics Corporation Model 1.5SDH-1 Pelletron Accelerator. The Direct/AMS laboratory has an overall precision and accuracy of 0.3 to 0.5% for modern samples (Zoppi et al. 2007).

Table A-2 presents the results of the analysis. As noted above, the $\delta^{13}\text{C}$ of all collagen samples submitted for dating, along with their atomic C:N ratios (see Ambrose and Norr 1992; Van Klinken 1999), were measured prior to submittal by CPSIL-NAU (see Table A-1). These independent $\delta^{13}\text{C}$ measures were used to correct for isotopic fractionation on individual dated samples.

Sample CAR 348, the bison standard, was prepared and run with these dates. This sample has been independently dated by Beta Analytic (224050) and has been dated multiple times during the PRL and Direct/AMS calibration. These previous results are presented in Figure A-1. The date for the sample run with the 41BX19 samples (3481 +/- 30) overlaps both with the Beta date (3490 +/- 40) and the majority of the previously run dates for this animal.

Finally, calibrated dates for all radiocarbon-dated samples are presented below, including the two samples dated by Beta Analytic. These are calibrated using OxCal (Bronk Ramsey 2009).

Table A-2. Collagen Radiocarbon Results for 41BX19 and Bison 1 (Standard)*

CAR C14 #	Description	% Modern Carbon	NAU Measured C13	Corrected Radiocarbon age BP	1 sigma error +/-	Direct AMS #
CAR 344	FS 3- bison	98.16	-10.97	158	23	7812
CAR 345	FS 152- large mammal	78.63	-18.15	1905	22	7813
CAR 346	FS 104- very large mammal	98.04	-12.96	155	23	7814
CAR 347	FS 9- mammal	79.53	-19.71	1848	26	7815
CAR 348	Bison 1- sample #348	64.76	-9.75	3481	30	7816

* This bison (Bison 1) is from plainview area that was previously dated by Beta Analytic at 3490 +/- 40.

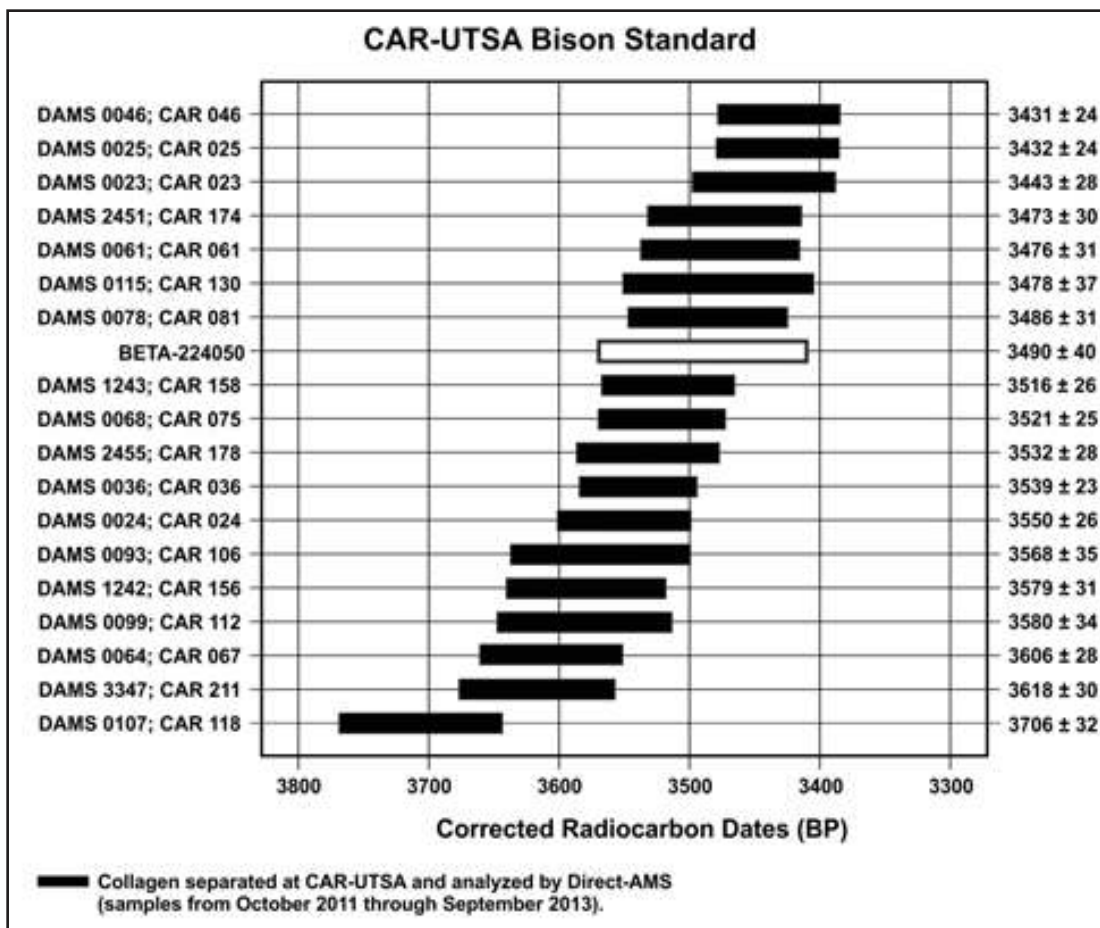
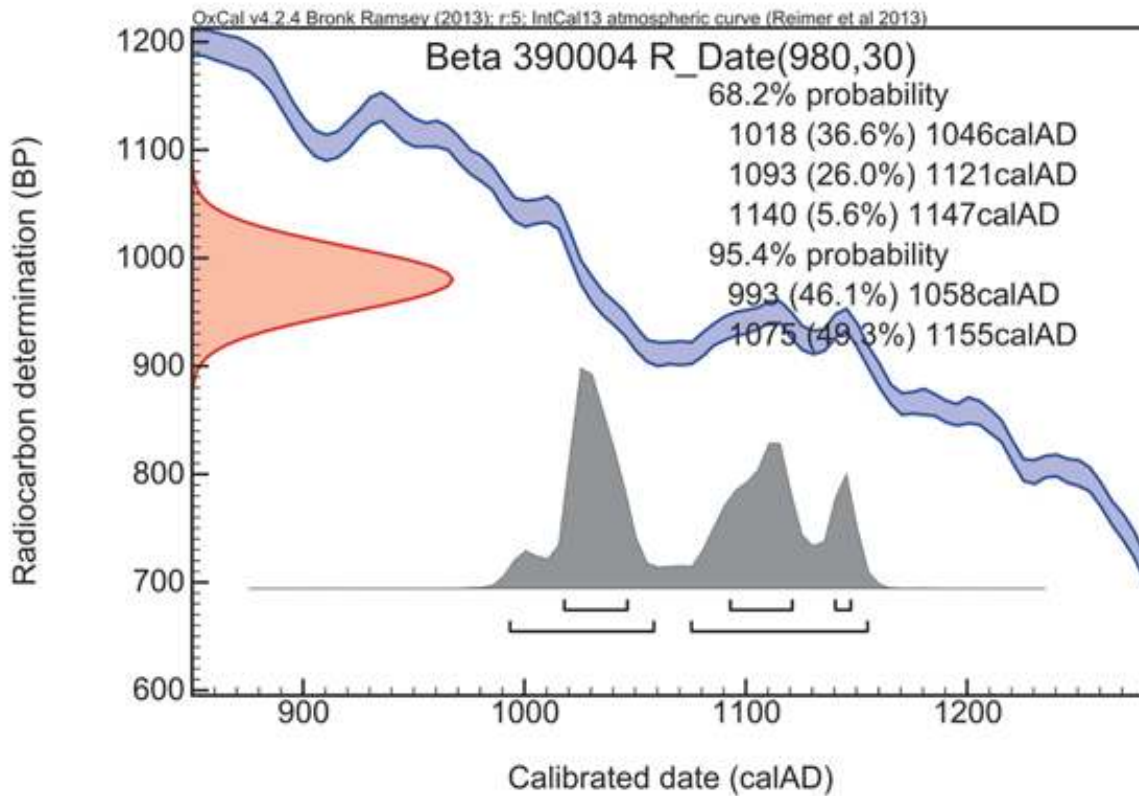
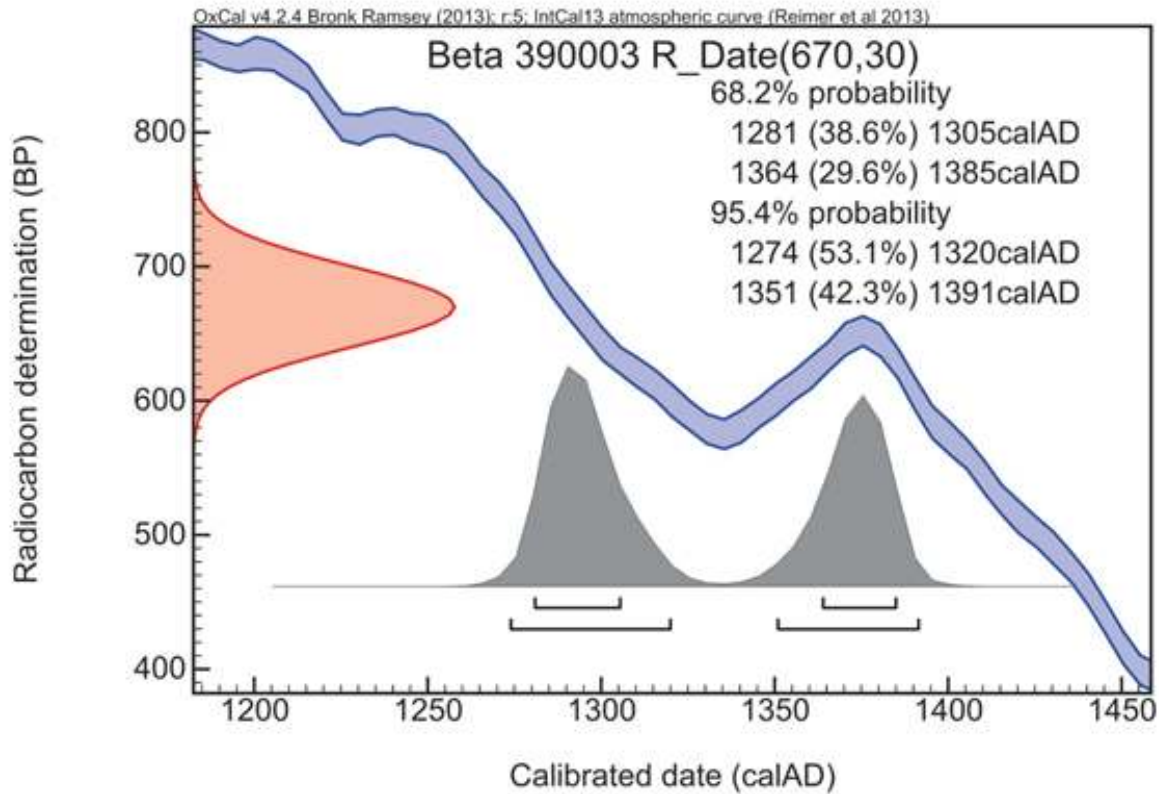
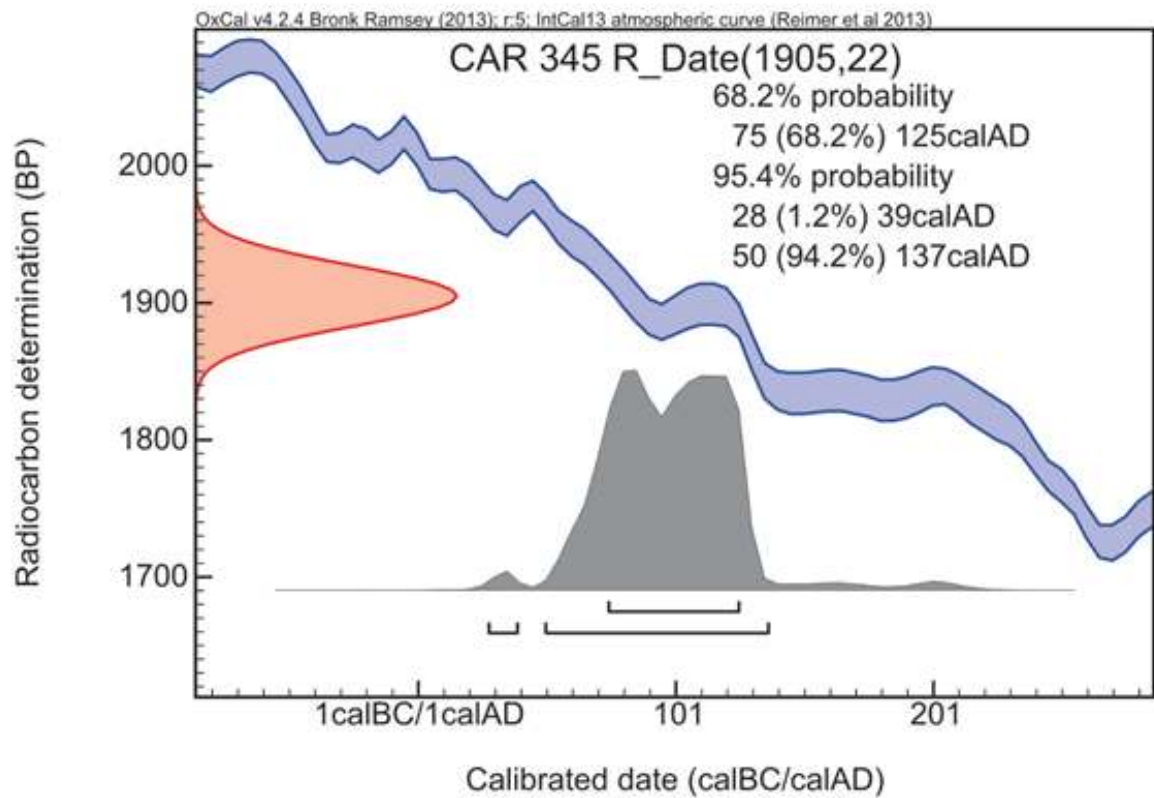
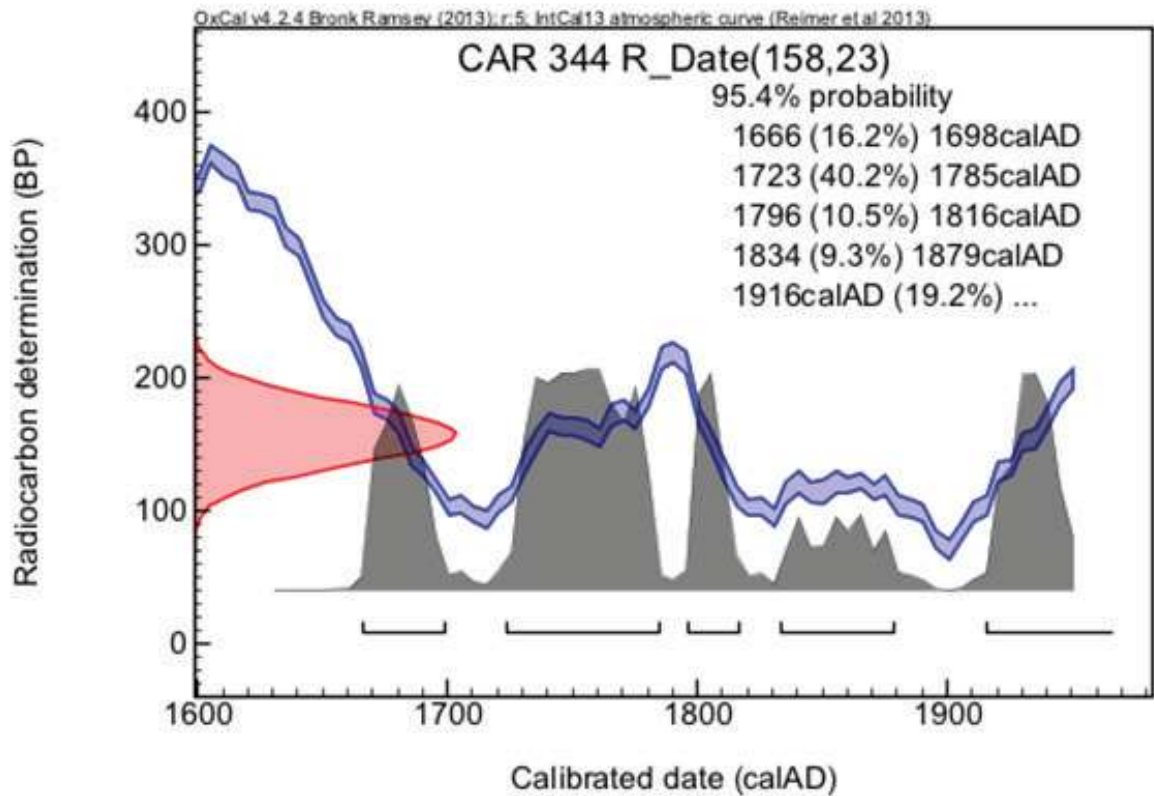
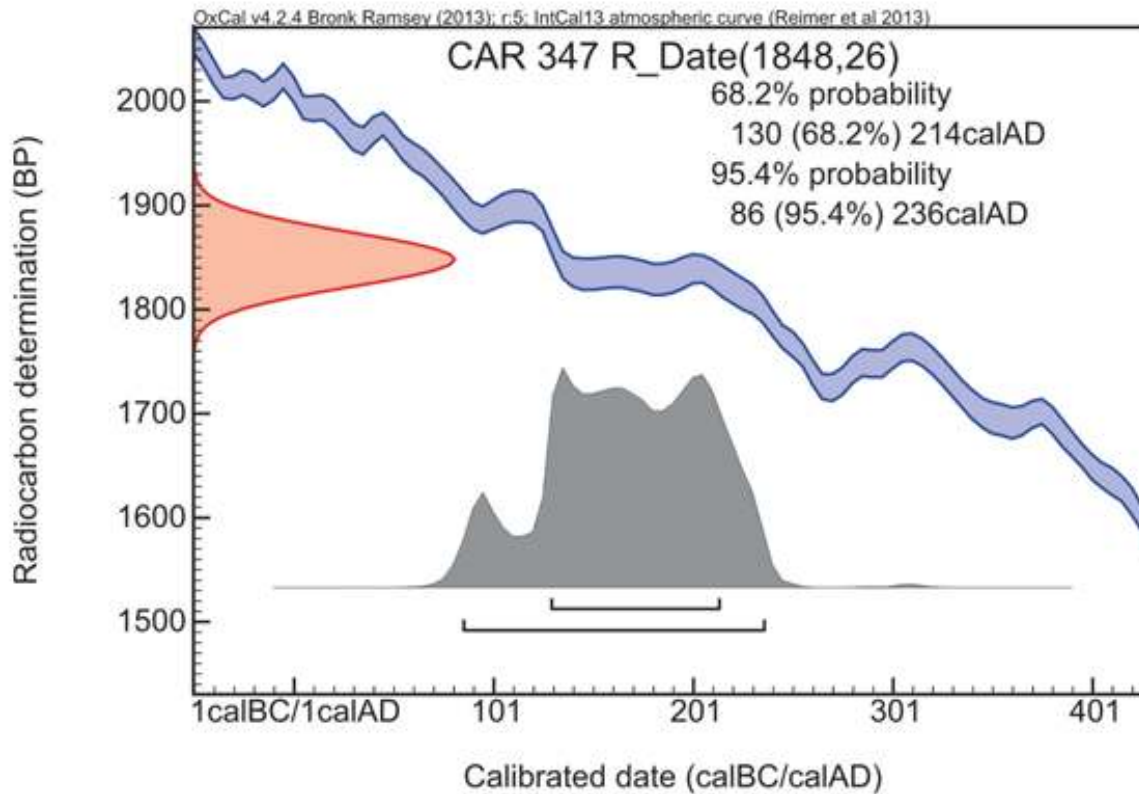
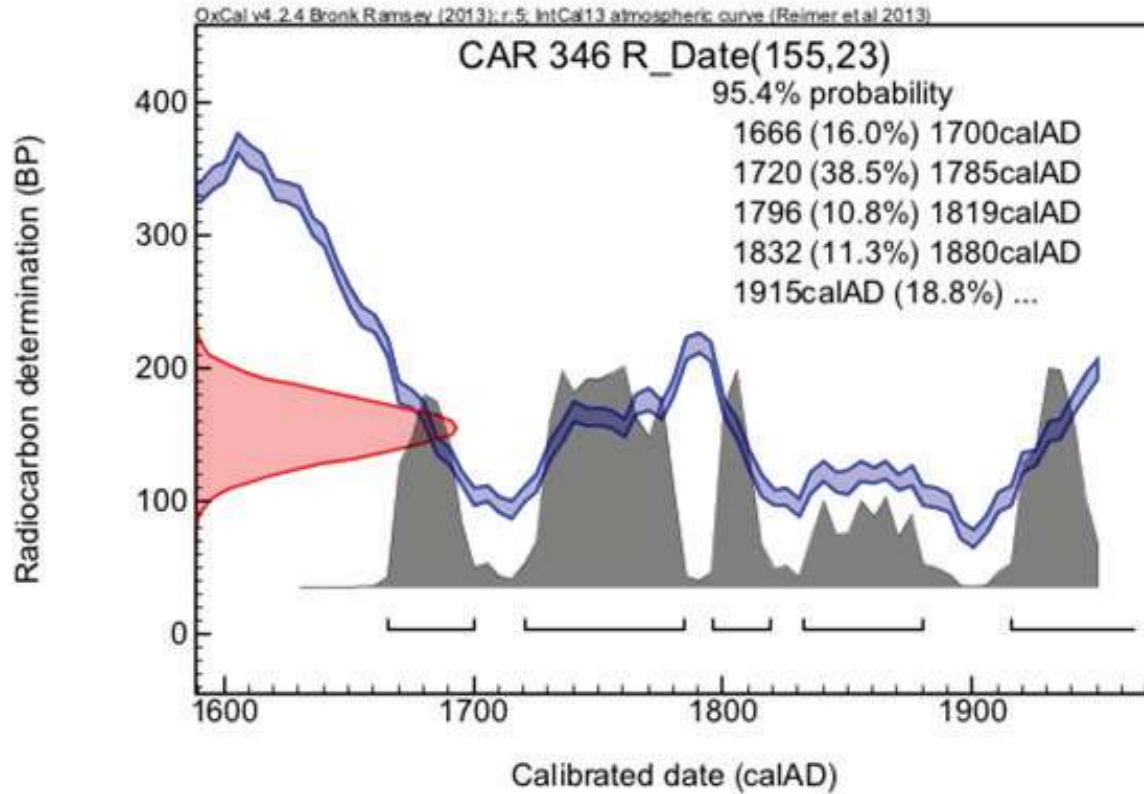

Figure A-1. Bison 1 standard dates (+/- 2 sigma range).







References Cited:

- Ambrose, S.H., and L. Norr
1992 On Stable Isotopic Data and Prehistoric Subsistence in the Soconusco Region. *Current Anthropology* 33:401-404.
- Bocherens, H., M. Fizet, A. Mariotti, B. Lange-Badre, B. Vandermeersch, J.P. Borel, and G. Bellon
1991 Isotopic Biogeochemistry (^{13}C , ^{15}N) of Fossil Vertebrate Collagen: Implications for the Study of Fossil Food Web Including Neanderthal Man. *Journal of Human Evolution* 20:481-492.
- Brock, F., T. Higham, P. Ditchfield, and C. Bronk Ramsey
2010 Current Pre-treatment Methods for AMS Radiocarbon Dating at the Oxford Radiocarbon Accelerator Unit (ORAU). *Radiocarbon* 52:103-112.
- Bronk Ramsey, C.
2009 Bayesian Analysis of Radiocarbon Dates. *Radiocarbon* 51:337-360.
- DeNiro, M.J., and S. Epstein
1981 Influence of Diet on the Distribution of Nitrogen Isotopes in Animals. *Geochimica et Cosmochimica Acta* 45:341-351.
- Longin, R.
1971 New Model of Collagen Extraction for Radiocarbon Dating. *Nature* 230:241-242.
- Mauldin, R.P., R.J. Hard, C.M. Munoz, J.Z. Rice, K. Verostick, D. Potter, and N. Dollar
2013 Carbon and Nitrogen Stable Isotope Analysis of Hunter-gathers from the Coleman Site, a Late Prehistoric Cemetery in Central Texas. *Journal of Archaeological Science* 40:1369-1381.
- Minami, M., H. Muto, and T. Nakamura
2004 Chemical Techniques to Extract Organic Fractions from Fossil Bones for Accurate ^{14}C Dating. *Nuclear Instruments and Methods in Physics Research B* 223-224, 302-307.
- Munoz C.M., R.P. Mauldin, D. Paul, and L. Kemp
2011 Monitoring Paleovegetation Shifts through Stable Carbon Isotope Variability in Archaeologically Recovered Leporids. *Texas Journal of Science* 63:113-140.
- van Klinken, G.J.
1999 Bone Collagen Quality Indicators for Palaeodietary and Radiocarbon Measurements. *Journal of Archaeological Science* 26:687-695.
- Zoppi, U., J. Crye, and Q. Song
2007 Performance Evaluation of the New AMS System at Accium BioSciences. *Radiocarbon* 49:171-180.

Appendix B:
Officials, Soldiers, and Civilians Who Were at
***Villa de Bejar* in 1718**
Robert Garcia, Jr.

Appendix B

Officials, Soliders, and Civilians Who Were at *Villa de Bejar* in 1718

Robert Garcia, Jr.

Soldiers, Civilians, and Friars	With Alarcon at Bejar, May 1, 1718*	Soldiers Assigned to Presidio, June 14, 1718**	Wives with 1718 Expedition***
Gobernador Don Martin de Alarcon	Yes	Yes	
Don Francisco Barreiro Y Alvarez (Military Engineer)	Yes	Yes	
Fray Antonio de San Buenaventura y Olivares	Yes		
Fray Francisco de Celiz	Yes		
Fray Joseph Guerra	Yes		
Capt. Santiago Ximenes		Yes	
Alferez Francisco Hernandes (died 1751)	Yes	Yes	Ana Garcia
Alferez Juan de Castro	Yes	Yes	Ana de Padilla
Sgt. Domingo Florez	Yes	Yes	Marzella Trevino
Sgt. Juan Barrera	Yes	Yes	
Don Diego de Escobar	Yes		Wife
Miguel Martines de Valensuela	Yes		
Don Diego de Zarate y Andizavar	Yes		
Xptobal Carauajal	Yes	Yes	
Joseph Flores Quiniones	Yes		
Juan Valdes	Yes	Yes	
Joseph Gaona	Yes		Wife
Nicolas Hernandes	Yes	Yes	
Francisco Hernandes (Son of Alferez)	Yes	Yes	
Joseph de Neira	Yes	Yes	
Joseph Velasques	Yes	Yes	
Francisco Menchaca	Yes	Yes	
Lazaro Joseph Chirino	Yes	Yes	Teresa Sanchez Navarro
Geronimo Carabajal	Yes	Yes	
Sebastian Peniche	Yes		
Antonio Guerra	Yes	Yes	
Don Francisco de Escobar	Yes		
Xptobal de la Garza (died abt. 1723)	Yes	Yes	
Sebastian Gonzales (Signed Writ Poss. Mission San Jose)	Yes	Yes	
Joseph Ximenes	Yes	Yes	
Manuel Maldonado	Yes	Yes	

Soliders, Civilians, and Friars	With Alarcon at Bejar, May 1, 1718*	Soliders Assigned to Presidio, June 14, 1718**	Wives with 1718 Expedition***
Manuel de Vargas	Yes		
Pedro Rodrigues	Yes		
Don Francisco Juan de la Cruz (Master Mason)	Yes		
Santiago Peres (Carpenter)	Yes		
Joseph Menchaca	Yes		
Joseph Antonio Menchaca	Yes		
Visente Guerra	Yes	Yes	
Joseph Plazido Flores	Yes	Yes	
Xptobal Barrera	Yes		
Francisco Rs		Yes	
Joseph Antonio Rs		Yes	
Marcelino Licona		Yes	
Andres de Sossa (died abt. 1719)		Yes	
Joseph Maldonado (died abt. 1720)		Yes	
Juan Galban		Yes	
Patricio de la Cruz		Yes	
Juan Domingo (de Castro)		Yes	
Antonio Perez		Yes	
Agustin Perez		Yes	
Joseph Cadena		Yes	
Miguel Hernandez		Yes	
Juan de Sosa		Yes	

* Provenencias Internas Vol. 181, p.222-224: Report of Cabildo Justicia and Regiment of the Villa of Santiago de la Monclova, Sept. 18, 1717; Briscoe Center for American History, U.T. Austin.

** Provenencias Internas Vol. 181, page 256, Archivo General de Mexico, Microfilm Photostatic Copy, Briscoe History Center, Univ. of Texas, Austin, Texas.

*** Mission San Antonio de Valero Baptism Book and Marriage Book for 1719, 1720, 1721, 1722- Los Bexarenos Genealogy Society Register, Vol. XI, No 4, p.221, "Inventory and Partition of Property of the Late Joseph Quinones".